

HAMBLLEN COUNTY LEGISLATIVE BODY

Regularly Scheduled Monthly Meeting
Thursday, June 25, 2026
5:00 p.m.

Open Meeting - Sheriff Chad Mullins

Call to Order - Chairman Bobby Haun

Prayer – Commissioner Tim Horner

Pledge of Allegiance – Commissioner Rodney Long

Roll Call - County Clerk Peggy Henderson

Prepared under the direction of:
Chairman Bobby Haun

Order #	Vote	Item
1		<u>Recognition/Presentations/Proclamations (Commission Chairman Bobby Haun)</u> a. None
2		<u>Public Comment (Commission Chairman Bobby Haun) (3 Minutes Per Speaker)</u> a. Regarding General/Non-Agenda Items b. Regarding Agenda Items
3	Vote	<u>Nominations/Appointments (Commission Chairman Bobby Haun)</u> a. Appointment to the Morristown-Hamblen Library Board
4	Vote Vote	<u>Calendar and Rules Committee Report (Chairman Thomas Doty)</u> a. Approval of Consent Calendar Items b. Approval of Regular Calendar Items
5		<u>Items Removed from Consent Calendar</u> a. None
6	Vote	<u>Approval of Consent Calendar (Commission Chairman Bobby Haun)</u> a. Consent Calendar
7		<u>RECESS AS HAMBLEN COUNTY LEGISLATIVE BODY-CONVENE AS HAMBLEN COUNTY BEER BOARD</u> a. Simpson Market and Deli-Hiral Patel, 8015 E Andrew Johnson Hwy, Whitesburg, TN 37891 <u>RECONVENE AS HAMBLEN COUNTY LEGISLATIVE BODY (Chairman Bobby Haun)</u>
8	Vote	<u>BEER PERMIT VOTE</u> a. Simpson Market and Deli-Hiral Patel, 8015 E Andrew Johnson Hwy, Whitesburg, TN 37891
9		<u>RECESS AS HAMBLEN COUNTY LEGISLATIVE BODY-OPEN PUBLIC HEARING (Commission Chairman Bobby Haun)</u> a. Public Hearing-FY 2026/2027 Budget <u>CLOSE PUBLIC HEARING RECONVENE AS HAMBLEN COUNTY LEGISLATIVE BODY (Commission Chairman Bobby Haun)</u>
10	Vote Vote Vote	<u>BUDGET COMMITTEE (Chairman Rodney Long)</u> a. Resolution <u>26-09</u> -Fixing the Tax Levy in Hamblen County, Tennessee for Fiscal Year Beginning July 1, 2026 b. Resolution <u>26-10</u> -Making Appropriations for the Various Fund Departments, Institutions, Offices, Agencies for Hamblen County, Tennessee for year Beginning July 1, 2026 and Ending June 30, 2027 c. Resolution <u>26-11</u> -Making Appropriations to Non-Profit, Charitable and Civic Organizations of Hamblen County, Tennessee for year Beginning July 1, 2026 and Ending June 30, 2027
11	Vote Vote Vote Vote Vote Vote Vote Vote Vote Vote Vote	<u>Finance Committee (Chairman Rodney Long)</u> a. Resolution <u>26-12</u> -A Resolution Authorizing the Hamblen County Sheriff's Office to Apply for the Statewide School Resource Officer (SRO) Program Grant in the Amount of \$1,350,000.00 b. Banking Contract HomeTrust Bank c. Amending Private Act-Private Chapter No. 57 House Bill No. 2640 Senate Bill No. 2705 114th General Assembly Section 2 the Hamblen County, Tennessee, Road Commission is Abolished Effective August 31, 2028. Should a Vacancy on the Road Commission Occur Prior to August 31, 2028, the Vacancy Shall not be Filled for the Remainder of the Unexpired Term. (for full description see private chapter No. 57) d. Amending Private Act-Private Chapter No. 58 House Bill No. 6242 Senate Bill No. 2703 114th General Assembly for County Attorney Section 1- County Attorney Shall be Elected by the Hamblen County Commission Annually at the September Meeting Designated for Election of County Attorney. Section 3 The County Attorney for Services Shall be Paid on Annual Retainer Fee of \$1,200. For Legal Services Performed on Behalf of County, the County Attorney Shall be Entitled to Receive Additional Reasonable Compensation and Reimbursement for Actual Expenses Incurred. (for full description see private chapter no. 58) e. MetTel Communications Solution Contract f. Annual Debt Report for Year Ending June 30, 2026 g. Construction Change Directive No. 04 \$5,059.00 h. Budget Amendments i. Hamblen County Department of Education Budget Amendment # 11 Increase of \$189,541.65 ii. Fund #101-General Fund-Multiple Categories (see attached) iii. Fund #116-Solid Waste/Sanitation Fund \$37,100 iv. Fund #128-Drug Use Abatement Fund \$360,288.76 v. Fund #131-Highway Department Fund \$24,300

	Vote	vi. Fund #151-General Debt Service Fund \$282,000
	Vote	vii. Fund #154-Special Debt Service \$151,800
	Vote	viii. Fund #176-Highway Capital Project Fund \$20,000
	Vote	i. Construction Change Directive No. 08 Lump Sum unchanged \$0.00
12		<u>Public Services Committee (Chairman Mike Richardson)</u>
	Vote	a. Resolution 26-13 -A Resolution to Amend the Subdivision Regulations of Hamblen County, Tennessee by Amending the Cul-De-Sac Size for New Subdivisions From 40 Feet to 50 Feet
	Vote	b. Resolution 26-14 -A Resolution to Update the Hamblen County, Tennessee Stormwater Program in Order to be in Compliance with TDEC
	Vote	c. 2026-2027 Road Paving Plan
13		<u>Announcements /Informational Items /Upcoming Meeting Dates (Commission Chairman Bobby Haun)</u>
		a. July 2026 Committee Meeting: Monday, July 13, 2026, at 5:00 p.m. at the Courthouse -Large Courtroom
		b. July 2026 Commission Meeting: Thursday, July 23, 2026, at 5:00 p.m. at the Courthouse- Large Courtroom
14		<u>Adjournment (Commission Chairman Bobby Haun)</u>

Thursday, June 25 , 2026

Hamblen County Government
Calendar & Rules Committee
Monday, June 15, 2026
Large Courtroom-Hamblen County Courthouse

MINUTES

Members Present:

Thomas Doty, Tim Horner, Bobby Haun, Debbie A’Hearn, Peggy Howell, Mike Reed, Mike Richardson

Member Absent:

Joe Huntsman, Sr.

Call to Order

Chairman Thomas Doty called the meeting to order at 5:46 p.m.

Visitors Wishing to Address the Committee

- a. None

Old Business

- a. None

New Business

- a. Review of Regular Calendar Items
Motion (Tim Horner/Mike Reed, all in favor) to approve the Regular Calendar Items as presented

- b. Review of the Consent Calendar Items
Motion (Tim Horner/Mike Reed, all in favor) to approve the Consent Calendar Items as presented

Items and Interest (No Action Necessary)

- a. None

Adjournment

There being no further business Chairman Doty adjourned the meeting at 5:48 p.m.

Hamblen County Government
CALENDAR & RULES COMMITTEE

Monday, June 15, 2026

Immediately Following Adjournment of the Public Services Committee
Large Courtroom of the Hamblen County Courthouse



**CALENDAR & RULES
COMMITTEE**

Thomas Doty
Chairman

Tim Horner
Vice-Chairman

Bobby Haun
Ex-Officio

Debbie A'Hearn
Member

Peggy Howell
Member

Joe Huntsman, Sr.
Member

Mike Reed
Member

Mike Richardson
Member

AGENDA

1. **Call to Order** – *Chairman Thomas Doty*
2. **Visitors Wishing to Address the Committee about Agenda Items Only** –
Chairman Thomas Doty (Visitors will be allotted 3 minutes to speak)
3. **Old Business** - *Chairman Thomas Doty*
 - a. None
4. **New Business** - *Chairman Thomas Doty*
 - a. Review of Regular Calendar Items
 - b. Review of Consent Calendar Items
5. **Items of Interest** - *Chairman Thomas Doty*
 - a. None
6. **Adjournment** – *Chairman Thomas Doty*

CONSENT CALENDAR**Thursday, June 25, 2026****Hamblen County Legislative Body**

Order #	Item	Placed From
1	Approval of the Previous Month's Minutes –May 21, 2026	Commission Chairman
2	Approval of Notaries	County Clerk Peggy Henderson
3	Jail/Justice Center Project Expenditures as of May 31, 2026	Justice Center/Public Safety Committee
4	Expenditure Reports – May 2026	Finance Committee
5	Revenue Summary Report- May 2026	Finance Committee
6	Monthly Checks- May 2026	Finance Committee
7	Planning Commission Building Permit Log – May 2026	Finance Committee
8	County Attorney Invoices –May 2026	Finance Committee
9	Trustee Report- May 1, 2026 – May 31, 2026	Finance Committee
10	Morristown Hamblen Emergency Medical Service Board of Directors Meeting Report April 22, 2026	Finance Committee
11	Hamblen County Department of Education Quarterly Report Third Quarter 2025-2026	Finance Committee
12	Approval of Education Pay Submissions Approval of Longevity Pay Submission	Personnel Committee
13	Approval of the Budget Committee Minutes-February 9, 2026, May 11, 2026, May 16, 2026, June 1, 2026, June 4, 2026, June 8, 2026	Budget Committee

Thursday, June 25, 2026



Morristown-Hamblen Library

417 WEST MAIN STREET, MORRISTOWN, TN 37814 TELEPHONE: 423-586-6410 / FAX: 423-587-

May 27, 2026

Chris Cutshaw, Mayor
Hamblen County Government
511 West Second North Street
Administrative Building, 1st floor
Morristown, TN 37814

Dear Mayor Cutshaw:

I am submitting the following nominee on behalf of the Hamblen County Library Board of Trustees for your consideration of Board representatives beginning immediately:

Amanda Hale, 3135 Chucky River Road, Morristown, TN 37813 to begin her second full term as County representative on July 1, 2026. She has been nominated to start his first full term May 26, 2026.

Sincerely,

Amanda Baysinger

Amanda Baysinger,
Interim Director

CERTIFICATE OF ELECTION OF NOTARIES PUBLIC

AS A CLERK OF THE COUNTY OF HAMBLEN, TENNESSEE I HEREBY CERTIFY TO THE SECRETARY OF STATE THAT THE FOLLOWING WERE ELECTED TO THE OFFICE OF NOTARY PUBLIC DURING THE JUNE 25, 2026 MEETING OF THE GOVERNING BODY:

NAME	HOME ADDRESS	HOME PHONE	BUSINESS ADDRESS	BUSINESS PHONE	SURETY
1. KAREN CARSON	2052 IVANHOE RD MORRISTOWN TN 37814	423-307-2519	818 W 1ST NORTH ST MORRISTOWN TN 37814	423-587-2800	
2. PATRICIA CASTEEL	5452 ENKA HWY MORRISTOWN TN 378135109	423-312-6039	218 S CUMBERLAND ST MORRISTOWN TN 378132301	423-307-1445	
3. TARA COOPER	1498 OVERVIEW DR MORRISTOWN TN 378141656	423-327-0924	1709 W ANDREW JOHNSON HWY MORRISTOWN TN 378143736	423-587-8848	
4. TONI SOFIA GUTIERREZ	2348 W ANDREW JOHNSON HWY MORRISTOWN TN 378143208	423-200-8896	2348 W ANDREW JOHNSON HWY MORRISTOWN TN 378143208	423-586-9136	
5. CANDI JOHNSON	1667 BOARDWALK CIR MORRISTOWN TN 378146492	865-227-9877	2311 IRIS LN NEW MARKET TN 378203325	865-227-9877	TIS
6. TAMMY MICHELLE JONES	943 SUMMIT RIDGE DR MORRISTOWN TN 378143489	865-674-0725	288 S DAISY ST MORRISTOWN TN 378132309	423-616-0051	
7. AMBER MAE RAMSEY	1312 ROCK HAVEN RD BEAN STATION TN 377083242	423-754-3180	155 TERRACE LN MORRISTOWN TN 378131997	--	
8. CYNTHIA A. REASONER	541 SYCAMORE ST MORRISTOWN TN 378131971	423-587-2467	101 N FAIRMONT AVE MORRISTOWN TN 378143769	423-586-7090	
9. ERICA THOMAS	810 S SUGAR HOLLOW RD MORRISTOWN TN 378132871	423-312-6666	506 W MORRIS BLVD MORRISTOWN TN 378132132	--	

Batch 185
Start: 5.12.26
End: 6.12.26



Peggy Henderson
SIGNATURE

CLERK OF THE COUNTY OF HAMBLEN, TENNESSEE

6-17-26
DATE

[Return to Regular Calendar](#)

BEER BOARD

June 2026



HAMBLLEN COUNTY CLERK

Peggy Henderson

511 W Second North Street, Morristown, TN 37814

Phone: (423)586-1993 Fax:(423)585-2015

June 1, 2026

TO ALL COUNTY COMMISSIONERS:

Enclosed, please find a beer permit application for Simpson Market & Deli
8015 E Andrew Johnson Hwy, Whitesburg, TN 37891. The Business owners is
Hiral Patel. This application is for consideration at the June 25, 2026
county commission meeting. The business is in the 9th district and will be for
off-premises beer permit.

Thank You,

Peggy Henderson

Hamblen County Clerk



BEER PERMIT CHECKIST

Applicant: SIMPSON MARKET & DELI

Circle One:

Yes No Application Received – Date Received: 05/18/2026

Yes No Application Fee Paid \$ 250.00 Date Paid: 05/18/2026

Yes No Advertised in Local Newspaper – Date: 06/10/2026

Yes No Notification Letter Mailed to Commissioners – Date: 06/01/2026

Yes No Criminal Background Check Completed (attached) 5/20/2026

Yes No Is property properly zoned? (Verify w/ Planning & Zoning – Zone: A-1)

Yes No Sales Tax Registration Received – Date Received: N/A

(New permit holder / due ten days after permit issued)

511 West Second North Street • Morristown, TN 37814

office (423) 256-1931 • fax (423) 585-4699

www.HamblenCountyTN.gov

APPLICATION FOR A BEER PERMIT

STATE OF TENNESSEE

COUNTY OF HAMBLEN

BOARD MEETING DATE: 5-21-26 MAP NO. 0130

TYPE OF PERMIT:

On-Premises

Off-Premises

On and Off Premises

Manufacturer's or Distributor's

Temporary (Special Event)

PARCEL NO. 003.01

On-Premises	<input type="checkbox"/>
Off-Premises	<input checked="" type="checkbox"/>
On and Off Premises	<input type="checkbox"/>
Manufacturer's or Distributor's	<input type="checkbox"/>
Temporary (Special Event)	<input type="checkbox"/>

I HEREBY MAKE APPLICATION FOR A PERMIT TO SELL, STORE, MANUFACTURE, OR DISTRIBUTE BEER OR OTHER BEVERAGES AUTHORIZED TO BE SOLD, STORED, MANUFACTURED OR DISTRIBUTED UNDER THE PROVISIONS OF TENNESSEE CODE ANNOTATED §57-5-101 ET SEQ., AND BASE MY APPLICATION UPON THE ANSWERS TO THE FOLLOWING QUESTIONS:

1. Full name of applicant: (owner of business) HIRAL PATEL
2. Type of applicant: (check one)

Person	Firm (LLC)	Corporation
Syndicate	Association	Joint-Stock Company

3. Give the name and address of all persons, firms, corporations, joint-stock companies, syndicates or associations who own 5% or more of the business (attach additional sheet, if needed)

HIRAL PATEL
1951 HINDLEY ROAD, MORRISTOWN, TN 37813

If The owner is an individual, answer Questions 4-8. Otherwise, proceed to Question 9

4. What is your present home address? 1951, HINDLEY, ROAD, MORRISTOWN, TN, 37813
5. Previous address(es) within the last ten years (use additional sheet if necessary)
2080 Jonathan Drive, Whitepine, TN.
6. Date of birth 13 Feb 1995

7. Applicant's home telephone H 226-886-2754
8. Applicant's business telephone H 423-393-4091
9. Under what name will the business operate
SIMPSON MARKET & DELI
10. Give business address and geographical location
8015 E ANDREW JOHNSON HWY
WHITESBURG TN 37891
11. Describe the nature of the business you will operate
CONVENIENCE STORE
12. Name and address of the person to receive annual tax notices and any other communication
Hiral Patel -
8015 E ANDREW JOHNSON HWY
WHITESBURG TN 37891
13. Name and address of property owner (if other than business owner)
Alex Kix 229 LLC
4890 S Davy Coletts Morristown TN 37813
14. Will this permit be used to operate two or more restaurants or other businesses within the same building? (yes or no) If yes, specify number _____
And list the names of all restaurants or other businesses and describe all locations (use separate sheet if necessary)
15. Give the name, date of birth, and address of any manager other than the applicant
HIRAL PATEL Feb 13th 1995
16. Has any person who owns five percent (5%) or more of the business, any manager listed in response to Question 15 above, or any other employee of the business, been convicted of any violation of the beer or alcoholic beverage laws or any crime (other than minor traffic violations) within the past ten (10) years? No If yes, give the particulars of each charge, the court, and the date convicted.
17. Have you, your business or any person who owns five percent (5%) or more of the business ever had a beer permit revoked, suspended or denied in the State of Tennessee Yes _____ No ✓

If yes, specify where, when and why

18. Give the name, relationship to the applicant (if applicable) and address of the former beer permittee at this location

Hiral Patel - 1951 Hindley Rd, Murristown TN 37813

Same owner - new Business.

19. Give the name of the owner and the address of the nearest residential dwelling to your business

113 Simpson Rd Whitesburg TN 37891

I CERTIFY THAT THIS APPLICATION CONTAINS TRUE INFORMATION TO THE BEST OF MY KNOWLEDGE AND BELIEF. I CERTIFY THAT I HAVE BEEN A CITIZEN OR LAWFUL RESIDENT OF THE UNITED STATES FOR AT LEAST ONE (1) YEAR IMMEDIATELY PRECEDING THE DATE THIS APPLICATION IS MADE TO THE COUNTY. I AM AWARE OF MY CONTINUING OBLIGATION TO AMEND OR SUPPLEMENT THIS APPLICATION PROMPTLY IF A CHANGE IN CIRCUMSTANCES AFFECTS THE RESPONSES PROVIDED IN THIS APPLICATION, EITHER BEFORE OF AFTER A PERMIT HAS BEEN ISSUED. I CERTIFY THAT I AM KNOWLEDGEABLE OF THE LAWS PROHIBITING THE SALE OF BEER TO MINORS. I AM AWARE THAT I WILL NOT BE ISSUED A BEER PERMIT OR MY PERMIT WILL BE REVOKED IF MY BUSINESS LOCATION CAUSES TRAFFIC CONGESTION OR INTERFERES WITH SCHOOLS, CHURCHES OR OTHER PLACES OF PUBLIC GATHERING OR OTHERWISE INTERFERES WITH PUBLIC HEALTH, SAFETY AND MORALS. I WILL SURRENDER TO THE BEER BOARD ANY PERMIT ISSUED UNDER THIS APPLICATION WITHIN FIFTEEN (15) DAYS OF TERMINATION OF THE BUSINESS, CHANGE IN OWNERSHIP, RELOCATION OF THE BUSINESS, OR CHANGE OF THE BUSINESS'S NAME.

Hiral Patel
Signature of Applicant/Owner (or authorized officer)

Sworn to and subscribed before me this 18th day of May, 2026.

Adriane Loveday
Notary Public

My Commission Expires 12-28-2026



NOTICE: A non-refundable \$250.00 fee must accompany this application. If the application is approved, you are required to provide documentation of sales tax registration to the county within ten(10) days of approval.

An annual privilege tax of \$100.00 is imposed on the business of selling, distributing, storing or manufacturing beer in this state. The tax is due each January 1 and is payable to the Hamblen County Clerk. This tax is prorated for new permits issued after January 1, and must be paid when the permit is issued.

ANY APPLICANT MAKING A FALSE STATEMENT IN THIS APPLICATION SHALL FORFEIT HIS OR HER PERMIT AND SHALL NOT BE ELIGIBLE TO RECEIVE ANY PERMIT FOR TEN (10) YEARS.

05/18/2026

**PEGGY HENDERSON
HAMBLÉN COUNTY CLERK**

511 W. 2ND NORTH ST
MORRISTOWN, TN 37814

**RECEIPT
0066670**

RECEIPT BOOK: GENERAL RECEIPTS - FEE IS NOT REFUNDABLE

Received Of	ITEM	QTY	EACH	EXTENSION
MAULIK PATEL	Beer Application	1	250.00	250.00
For			Total	250.00

BEER PERMIT

Mail To

Cash 250.00
 Check .00
 Credit Card .00
 Change .00

BY

WK01 31 ED

DETACH ALONG THIS LINE

05/18/2026

**PEGGY HENDERSON
HAMBLÉN COUNTY CLERK**

511 W. 2ND NORTH ST
MORRISTOWN, TN 37814

**RECEIPT
0066670**

RECEIPT BOOK: GENERAL RECEIPTS - FEE IS NOT REFUNDABLE

Received Of	ITEM	QTY	EACH	EXTENSION
MAULIK PATEL	Beer Application	1	250.00	250.00
For			Total	250.00

BEER PERMIT

Mail To

Cash 250.00
 Check .00
 Credit Card .00
 Change .00

BY

WK01 31 ED

PEGGY HENDERSON, HAMBLÉN COUNTY CLERK

**LICENSE
0376995**

STANDARD BUSINESS TAX LICENSE

Total Due: 15.00
Cash: 20.00 Check: Check No.: Change: 5.00
ERIN WK01 Drawer: 31 Site: 1
Work Date: 05/15/2026

DETACH THIS PORTION FOR CONFIDENTIAL FILE

**PEGGY HENDERSON
HAMBLÉN COUNTY CLERK**
511 W. 2ND NORTH ST
MORRISTOWN, TN 37814

**LICENSE
0376995**

STANDARD BUSINESS TAX LICENSE

Mailing

Location

78316 SIMPSON MARKET & DELI

SIMPSON MARKET & DELI

8015 E ANDREW JOHNSON HWY
WHITESBURG, TN 37891

8015 E ANDREW JOHNSON HWY
WHITESBURG, TN 37891

LOCAL ACCOUNT NUMBER 78316
STATE ACCOUNT NUMBER 1001950628
TRANSACTION NUMBER _____
CLASS 02
SALES TAX NUMBER _____

ISSUE DATE 05/18/26
TAX PERIOD STARTED - 05/14/2026
PAYMENT DUE BY 4/15/2027
EXPIRATION DATE 5/15/2027

TO AVOID PENALTY, INTEREST, AND POTENTIAL ENFORCED COLLECTION ACTION, BUSINESS TAX RETURNS AND PAYMENTS MUST BE REMITTED TO THE TENNESSEE DEPARTMENT OF REVENUE AT LEAST 30 DAYS PRIOR TO THE EXPIRATION DATE OF THIS LICENSE.

IF PAID BY CHECK, THIS LICENSE VALID ONLY AFTER CHECK IS PAID.

THIS LICENSE DOES NOT PERMIT OPERATION UNLESS PROPERLY ZONED, AND/OR IN COMPLIANCE WITH ALL OTHER APPLICABLE LAWS/RULES.



DEPUTY CLERK SIGNATURE

ERIN WK01 Drawer:31 Site:1

-- POST AT LOCATION OF BUSINESS --
IF BUSINESS CLOSES, MOVES, OR CHANGES OWNERS, NOTIFY THIS OFFICE

[Return to Regular Calendar](#)



Column Software PBC
PO Box 208098
Dallas, TX 75320-8098
help.column.us

Invoice number I5V0HZIV-0002
Notice ID Rb9PBFCBHFQyBY4lJrT M
Publisher Citizen Tribune
Date of issue Jun 4, 2026
Date due Jul 4, 2026
Amount due **\$52.30**

Bill to
Hamblen County Government

Description	Qty	Unit price	Amount
06/10/2026: Public Notices Notice	1	52.30	52.30
=== Notes === Notice Name: public notice - beer permit			Net Subtotal \$52.30
=== How to pay this invoice === Column Software PBC accepts online payment via credit or debit card, or ACH bank transfers. Please click here to pay online: https://www.column.us/invoices/KJoAa0d6Y8GKUfLSuyLT/pay			Tax 0.00
			Amount due \$52.30

Please note that, once paid, the merchant name on your billing statements will be Column Software PBC.

Select organizations may also pay via check. Checks will result in processing delays and should not be used if your notice requires upfront payment. Please pay the exact amount due, write your invoice number I5V0HZIV-0002 on the memo, include a printed copy of your Invoice PDF, make the check payable to Column Software PBC, and mail to the address above.

Pay here: <https://www.column.us/invoices/KJoAa0d6Y8GKUfLSuyLT/pay>

Questions? Visit help.column.us

Public Notice

Beer Permit to be considered at the June 25, 2026 Hamblen County Commission meeting to be held at the Hamblen County Courthouse, Large Courtroom at 5:00 pm.

Business Name:
Simpson Market & Deli
Address:
8015 E Andrew Johnson Hwy
Whitesburg, TN 37891

Business Owner:
Hiral Patel

Phone Number:
423 393 4091

District:
9th District
off-premise permit

Publish Date:
June 10, 2026.



THIS RECORDS CHECK COVERS
APPROXIMATELY THE LAST 15 YEARS

Hamblen County Clerk
Peggy Henderson
511 W Second North St.
Morristown, TN 37814
Phone: 423 586 1993
Fax: 423 585 2015

NO RECORDS FOUND
MAY 22 2026

Date:

TO: SHERIFF CHAD MULLINS
FROM: PEGGY HENDERSON, HAMBLEN COUNTY CLERK
RE: BEER LICENSE APPLICATION

Attached is a copy of an application for a beer permit in Hamblen County. The Beer Board has requested that you verify any conviction of any crime (other than traffic violations) within the last 10 years for the owner of the business and any name listed in question #15. Once verified, please sign below and return to my office before the next County Commission meeting.

Thank You,
Peggy Henderson, Hamblen County Clerk

Findings are as follows:

Signature: TAMI PROFFIT

Date: 5.22.26

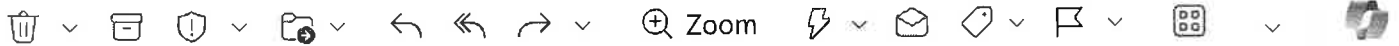

Re: Beer Permit Summarize this email

DM Donna Massey
To: April Barnard



Tue 5/19/2026 11:00 AM

April,

This property is zoned A-1, which can have a Gas station in that zone.

Thanks

Donna Massey
Administrative Assistant
Planning & Zoning

donna.massey@co.hamblen.tn.us



From: April Barnard <ABarnard@CO.hamblen.tn.us>
Sent: Tuesday, May 19, 2026 10:06 AM
To: Donna Massey <donna.massey@CO.hamblen.tn.us>
Subject: Beer Permit

Can you please check for me if property properly zoned ?

Simpson Market & Deli (Hiral Patel)
8015 E Andrew Johnson Hwy
Whitesburg, TN 37891



April Barnard
Hamblen County Government
Deputy Clerk
511 West Second North St
Morristown, TN 37814
Tel: (423) 586-1993 Ext: 1183

[Return to Regular Calendar](#)



Re: Beer Permit Summarize this email

DM Donna Massey
To: April Barnard



Tue 5/19/2026 1:33 PM

You replied on Tue 5/19/2026 1:49 PM

[View conversation](#)

Start reply with:

Yes, the Map 0130 Group A Parcel 003.01

Have a great day!

Donna Massey
Administrative Assistant
Planning & Zoning

donna.massey@co.hamblen.tn.us



From: April Barnard <ABarnard@CO.hamblen.tn.us>
Sent: Tuesday, May 19, 2026 12:51 PM
To: Donna Massey <donna.massey@CO.hamblen.tn.us>
Subject: Beer Permit

Would you be able to tell me the map, group and parcel on the
8015 E Andrew Johnson Hwy
Whitesburg, TN 37891



April Barnard
Hamblen County Government
Deputy Clerk
511 West Second North St
Morristown, TN 37814
Tel: (423) 586-1993 Ext: 1183

[Return to Regular Calendar](#)

**MINUTES FOR HAMBLEN COUNTY
LEGISLATIVE BODY
COMMISSION MEETING**

May 21, 2026

See Page 242

Hamblen County Government
Justice Center/Public Safety Committee
Monday, June 15, 2026
Hamblen County Courthouse-Large Courtroom

MINUTES

Members Present

Tim Horner, Mike Richardson, Bobby Haun, Jamie Carden, Debbie A’Hearn, Thomas Doty, Edna Greene, Stan Harville, Peggy Howell, Rodney Long, Wayne NeSmith, Mik Reed, Kyle Walker

Members Absent

Joe Huntsman, Sr.

Call to Order

Chairman Tim Horner called the meeting to order at 5:00 p.m.

Visitors Wishing to Address the Committee

- a. None

Old Business

- a. None

New Business

- a. Justice Center Project Update- Hamblen County Mayor Chris Cutshaw updated the Committee on the status of the Justice Center Project.

No Action Taken/Informational Purposes Only

Items of Interest (No Action Necessary)

- a. Jail/Justice Center Project Expenditures as of May 31, 2026.

Adjournment

There being no further business Chairman Horner adjourned the meeting at 5:06 p.m.



Hamblen County Government
JUSTICE CENTER/PUBLIC SAFETY COMMITTEE

Monday, June 15, 2026
Large Courtroom-Hamblen County Courthouse

AGENDA

Tim Horner
Chairman

Mike Richardson
Vice-Chairman

Bobby Haun
Ex-Officio

Jamie Carden
Member

Debbie A'Hearn
Member

Thomas Doty
Member

Edna Greene
Member

Stan Harville
Member

Peggy Howell
Member

Joe Huntsman, Sr.
Member

Rodney Long
Member

Wayne NeSmith
Member

Mike Reed
Member

Kyle Walker
Member

1. **Call to Order** – *Chairman Tim Horner*
2. **Visitors Wishing to Address the Committee about Agenda Items Only** –
Chairman Tim Horner (Visitors will be allotted 3 minutes to speak)
3. **Old Business**-*Chairman Tim Horner*
 - a. None
4. **New Business**- *Chairman Tim Horner*
 - a. Justice Center Project Update
5. **Items of Interest (No Action Necessary)** – *Chairman Tim Horner*
 - a. Jail/Justice Center Project Expenditures as of May 31, 2026
6. **Adjournment** – *Chairman Tim Horner*

Hamblen County Government
 Jail / Justice Center Project Expenditures
 As of May 31, 2026

Category of Costs	Description	Amount	Total Per Category
Moseley Architects			
Paid Prior to FY2021	Phase I and II & Design & Construction Planning Phase	\$ 943,700.00	
Paid in FY2021	Design & Construction Planning Phase	\$ 699,828.51	
Paid in FY2022	Design & Construction Planning Phase	\$ 3,114,662.02	
Paid in FY2023	Design & Construction Planning Phase	\$ 465,833.45	
Paid in FY2024	Design & Construction Planning Phase	\$ 356,908.88	
Paid in FY2025	Design & Construction Planning Phase	\$ 34,238.00	
			\$ 5,615,170.86
BurWil Construction			
Paid in FY2021	Project Management	\$ 283,597.96	
Paid in FY2022	Project Management	\$ 227,515.00	
Paid in FY2023	Project Management	\$ 313,002.65	
Paid in FY2024	Project Management	\$ 197,339.35	
Paid in FY2025	Project Management	\$ 43,025.41	
Paid in FY2026	Project Management	\$ 8,237.35	
			\$ 1,072,717.72
Blaine Construction			
Paid in FY2022	Construction	\$ 18,460,845.00	
Paid in FY2023	Construction	\$ 29,880,119.16	
Paid in FY2024	Construction	\$ 33,920,943.95	
Paid in FY2025	Construction	\$ 11,397,286.00	
Paid in FY2026	Construction	\$ 1,392,000.10	
			\$ 95,051,194.21
Entegrity Consulting			
Paid in FY2021	Commissioning Services	\$ 3,294.00	
Paid in FY2022	Commissioning Services	\$ 4,392.00	
Paid in FY2023	Commissioning Services	\$ 6,807.60	
			\$ 14,493.60
Property Acquisition			
Paid Prior to FY2021		\$ 1,250,751.07	
Paid in FY2021		\$ 895,659.17	
Paid in FY2022		\$ 1,326.52	\$ 2,147,736.76
FF&E Costs			
Paid in FY2024		\$ 60,759.34	
Paid in FY2025		\$ 967,925.18	
Paid in FY2026		\$ 235,521.25	\$ 1,264,205.77
Other Costs			
Paid Prior to FY2021	Site Preparation, Clearing, and Soil Testing and All Other Costs	\$ 109,649.17	
Paid in FY2021	Site Preparation, Clearing, and Soil Testing and All Other Costs	\$ 169,962.00	
Paid in FY2022	Site Preparation, Clearing, and Soil Testing and All Other Costs	\$ 122,120.00	
Paid in FY2023	Site Preparation, Clearing, and Soil Testing and All Other Costs	\$ 159,112.50	
Paid in FY2024	Site Preparation, Clearing, and Soil Testing and All Other Costs	\$ 46,855.00	
Paid in FY2025	Site Preparation, Clearing, and Soil Testing and All Other Costs	\$ 12,297.50	
9/29/2022	MUS - Tap & Impact Fees for Jail Connections	\$ 54,000.00	
Paid in FY2023	Deacon Foodservice Solutions	\$ 251,563.81	
Paid in FY2024	Deacon Foodservice Solutions	\$ 206,792.19	
Paid in FY2025	Deacon Foodservice Solutions	\$ 34,683.43	
1/12/2023	TN Dept of Environment & Conservation - Storm Water Annual Fee	\$ 500.00	
1/4/2024	Professional Svcs - Bond Compliance Specialists	\$ 2,650.00	
1/11/2024	TN Dept of Environment & Conservation - Storm Water Annual Fee	\$ 500.00	
FY 24-25	Professional Svcs - Bond Compliance Specialists	\$ 1,775.00	
FY 25-26	Professional Svcs - Bond Compliance Specialists	\$ 650.00	
FY 25-26	Inspection Fees	\$ 27,613.00	
			\$ 1,200,723.60
Total Expenditures on Jail / Justice Center Project			\$ 106,366,242.52

BUDGET RESOLUTIONS

BUDGET COMMITTEE MINUTES

RESOLUTION 26 - 09

**RESOLUTION FIXING THE TAX LEVY IN
HAMBLÉN COUNTY, TENNESSEE
FOR FISCAL YEAR BEGINNING JULY 1, 2026**

SECTION 1. BE IT RESOLVED by the Board of County Commissioners of Hamblen County, Tennessee, meeting in a regularly scheduled Commission meeting on the 25th day of June, 2026, that the combined property tax rate for Hamblen County, Tennessee for the year beginning July 1, 2026, shall be \$1.31 on each \$100 of taxable property inside the corporate limits of the City of Morristown and \$1.47 on each \$100 of taxable property outside the corporate limits of the City of Morristown, which is to provide revenue for each of the following funds and otherwise conform to the following tax levies:

FUND	<u>Inside Rate</u>	<u>Outside Rate</u>
General	\$0.8173	\$0.8173
General Debt Service	0.2401	0.2401
General Purpose School	0.2526	0.2526
Solid Waste/Sanitation		0.16
TOTAL	<u>\$1.31</u>	<u>\$1.47</u>

SECTION 2. BE IT FURTHER RESOLVED, that all resolutions of the Board of County Commissioners of Hamblen County, Tennessee, which are in conflict with this resolution are hereby repealed.

SECTION 3. BE IT FURTHER RESOLVED, that there is hereby levied a gross receipts business tax as provided by law. The proceeds of the gross receipts tax herein levied shall accrue to the General Fund.

SECTION 4. BE IT FURTHER RESOLVED, that there is levied a motor vehicle privilege tax as provided by law. The proceeds of the \$50 motor vehicle privilege tax herein levied shall accrue \$50 (100%) to the Highway Capital Projects Fund (#176).

SECTION 5. BE IT FURTHER RESOLVED, that there is levied a hotel/motel occupancy tax as provided by law. The proceeds of the hotel/motel occupancy tax herein levied shall accrue to the General Fund for the specific purpose of capital improvements to Cherokee Park.

SECTION 6. BE IT FURTHER RESOLVED, that a local option sales tax is levied as provided by law. The first 50% of the sales tax shall accrue to the General Purpose School Fund; of the remaining 50%, the first \$200,000 shall accrue to the Highway/Public Works Fund (#131), and the remainder shall accrue to the Solid Waste/Sanitation Fund (#116).

SECTION 7. BE IT FURTHER RESOLVED, that revenues derived from State Revenue Sharing - T.V.A. shall accrue as follows: the first \$200,000 shall accrue to the Highway/Public Works Fund (#131), and the remaining revenues shall accrue to the General Fund (#101).

SECTION 8. BE IT FURTHER RESOLVED, that revenues derived from interest earned on the cash balances in the Central Cafeteria Fund (#143) shall accrue to that fund; revenues derived from interest earned on the cash balances in the Drug Control Fund (#122) shall accrue to that fund; revenues derived from interest earned on the cash balances in the

Special Debt Service Fund (#154) shall accrue to that fund; revenues derived from the interest earned on the cash balances in the Other Capital Projects Fund (#178) shall accrue to that fund; revenues derived from interest earned on the cash balances in the Other Capital Projects Fund (#189) shall accrue to that fund; revenues derived from interest earned on the cash balances in the Drug Use Abatement Fund (#128) shall accrue to that fund; revenues derived from interest earned on the cash balances of all other operating funds shall accrue as follows: the first \$500,000 of interest shall accrue to the Solid Waste/Sanitation Fund (#116), the second \$120,000 of interest shall accrue to the Highway/Public Works Fund (#131), and all remaining interest earned shall accrue to the General Debt Service Fund (#151).

SECTION 9. BE IT FURTHER RESOLVED, that this resolution takes effect from and after its passage, the public welfare requiring it. This resolution shall be spread upon the minutes of the Board of County Commissioners.

Passed this 25th day of June, 2026.

Motion made by Commissioner _____

Seconded by Commissioner _____.

Aye:

Nay:

Absent:

Pass:

Abstain:

Chairman

County Mayor

Attest:

County Clerk

RESOLUTION 26-10

**A RESOLUTION MAKING APPROPRIATIONS FOR THE VARIOUS FUNDS,
DEPARTMENTS, INSTITUTIONS, OFFICES AND AGENCIES OF HAMBLEN COUNTY,
TENNESSEE FOR THE YEAR BEGINNING JULY 1, 2026 AND ENDING JUNE 30, 2027**

SECTION 1. BE IT RESOLVED by the Board of County Commissioners of Hamblen County, Tennessee, meeting in a regularly scheduled Commission meeting on the 25th day of June, 2026, that the amounts hereafter set out are hereby appropriated for the purpose of meeting the expenses of the various funds, departments, institutions, offices and agencies of Hamblen County, Tennessee, for the capital outlay, and for meeting the payment of principal and interest on the county's debt maturing during the year beginning July 1, 2026, and ending June 30, 2027, according to the following schedule:

General Fund

51100	County Commission	\$	193,515
51210	Board of Equalization		8,350
51300	County Mayor		293,112
51400	County Attorney		51,303
51500	Election Commission		450,682
51600	Register of Deeds		485,390
51720	Planning		302,755
51750	Codes Compliance		84,040
51760	Geographical Information Systems		111,629
51810	Other Facilities		1,604,367
51900	Other General Administration		16,500
51910	Preservation of Records		26,672
52100	Accounting and Budgeting		696,518
52300	Property Assessor's Office		521,308
52310	Reappraisal Program		188,402
52400	County Trustee's Office		497,162
52500	County Clerk's Office		1,097,184
52600	Data Processing		289,651
53100	Circuit Court		1,287,004
53300	General Sessions Court - Court I		562,051
53300	General Sessions Court - Court II		274,011
53330	Drug Court		244,470
53400	Chancery Court		494,420
53500	Juvenile Court		419,316
53900	Mental Health Court		183,470
53910	Probation Services		336,925
53920	Courtroom Security		1,480,615
54110	Sheriff's Department		4,757,164
54120	Special Patrols (SRO's)		1,848,100
54160	Administration of Sexual Offender Registry		8,000
54210	Jail		9,552,427
54220	Workhouse		132,520
54250	Work Release Program		274,631
54310	Fire Prevention and Control		320,000
54410	Civil Defense		196,694
54490	Other Emergency Management		270,752
54510	Inspection and Regulation		6,844
54610	County Coroner/Medical Examiner		250,650
54710	Drug Court Expansion		401,744

RESOLUTION 26-10

54900	Other Public Safety	98,000
55110	Local Health Center	1,705,543
55120	Rabies and Animal Control	464,217
55140	Nursing Home	-
55170	Alcohol and Drug Programs	-
55390	Appropriations to State	115,233
55520	Aid to Dependent Children (SafeSpace)	-
55590	Other Local Welfare Services	15,300
55710	Sanitation Management	21,710
55900	Other Public Health & Welfare	90,000
56100	Adult Activities	11,600
56300	Senior Citizen's Assistance	6,500
56500	Libraries	397,580
56700	Parks and Fair Boards	370,005
56900	Other Social, Cultural, and Recreational	160,000
57100	Agricultural and Natural Resources	232,544
57300	Forest Service	1,000
57500	Soil Conservation	98,007
57800	Storm Water Management	102,311
58110	Tourism	92,500
58120	Industrial Development	691,000
58300	Veterans' Service	43,556
58600	Employee Benefits	1,266,518
58900	Miscellaneous	451,300
73300	Community Services	5,000
91110	General Administration Projects	222,000
91120	Administration of Justice Projects	-
91130	Public Health Safety Projects	174,000
91140	Public Health and Welfare Projects	-
91150	Other Social, Cultural, and Recreational Projects	-
91190	Other General Government Projects	-
99100	Transfers Out	-
	Total General Fund	\$ 37,055,774
	<u>Solid Waste / Sanitation Fund</u>	
55710	Sanitation Management	\$ 4,809,353
99100	Transfers Out	-
	Total Solid Waste / Sanitation Fund	\$ 4,809,353
	<u>Drug Control Fund</u>	
54150	Drug Enforcement	\$ 97,081
	Total Drug Fund	\$ 97,081

RESOLUTION 26-10

Highway / Public Works Fund

61000	Administration	\$	566,925
62000	Highway and Bridge Maintenance		1,907,535
63100	Operation and Maintenance of Equipment		665,080
66000	Employee Benefits		26,916
68000	Capital Outlay		494,692
99100	Transfers-out		-
			<hr/>
	Total Highway / Public Works Fund	\$	<u>3,661,148</u>

General Purpose School Fund

71000	<u>Instruction</u>		
71100	Regular Instruction Program	\$	57,358,640
71200	Special Education Program		10,018,279
71300	Vocational Education Program		5,214,025
71400	Student Body Education Program		193,000
72000	<u>Support Services</u>		
72110	Attendance		4,789
72120	Health Services		1,243,192
72130	Other Student Support		3,209,751
72210	Regular Instruction Program		3,447,373
72220	Special Education Program		1,559,381
72230	Vocational Education Program		504,528
72250	Technology		2,579,391
72310	Board of Education		2,176,910
72320	Director of Schools		859,315
72410	Office of the Principal		6,624,245
72510	Fiscal Services		775,536
72520	Human Resources / Personnel		307,886
72610	Operation of Plant		7,474,578
72620	Maintenance of Plant		2,147,150
72710	Transportation		4,766,829
73000	<u>Operation of Non-Instructional Services</u>		
73300	Community Services		694,837
73400	Early Childhood Education		1,717,324
76000	<u>Capital Outlay</u>		
76100	Regular Capital Outlay		9,366,642
82300	<u>Other Debt Service</u>		
82330	Education - Other Debt Service		500,000
99000	<u>Other Uses</u>		
99100	Transfers Out		28,244
			<hr/>
	Total General Purpose School Fund	\$	<u>122,771,845</u>

Central Cafeteria Fund

73000	<u>Operation of Non-Instructional Services</u>		
73100	Food Service	\$	15,693,056
99100	In-Direct Cost		475,000
			<hr/>
	Total Central Cafeteria Fund	\$	<u>16,168,056</u>

RESOLUTION 26-10

General Debt Service Fund

82100	<u>Principal on Debt</u>		
82110	General Government	\$	3,278,825
82120	Highways and Streets		-
82130	Education		1,632,535
82200	<u>Interest on Debt</u>		
82210	General Government		3,345,795
82220	Highways and Streets		-
82230	Education		1,669,187
82300	<u>Other Debt Service</u>		
82310	General Government		163,000
82330	Education		2,825
			<hr/>
	Total General Debt Service Fund	\$	<u>10,092,167</u>

Special Debt Service Fund

82100	<u>Principal on Debt</u>		
82110	General Government	\$	541,989
82200	<u>Interest on Debt</u>		
82210	General Government		440,313
82300	<u>Other Debt Service</u>		
82310	General Government		-
99000	<u>Other Uses</u>		
99100	Transfers Out		-
			<hr/>
	Total Special Debt Service Fund	\$	<u>982,302</u>

Highway Capital Projects Fund

91200	Highway and Street Capital Projects	\$	<u>563,000</u>
			<hr/>
	Total Highway Capital Projects Fund	\$	<u>563,000</u>

BE IT FURTHER RESOLVED, that the budget for the School Federal Projects Fund shall be the budget approved for separate projects within the fund by the Tennessee Department of Education and the Hamblen County Board of Education.

SECTION 2. BE IT FURTHER RESOLVED, that there are also hereby appropriated certain portions of the commissions and fees for collecting taxes and licenses and for administering other funds which the Trustee, County Clerk, Circuit Court Clerk, Clerk and Master, Register, and the Sheriff and their officially authorized deputies and assistants may be entitled to receive under State laws heretofore or hereafter enacted. Expenditures out of commissions, and/or fees collected by the Trustee, County Clerk, Circuit Court Clerk, Clerk and Master, Register and the Sheriff may be made for such purposes and in such amounts as may be authorized by existing law or by valid order of any court having power to make such appropriations. Any excess commissions and/or fees collected over and above the expenditures duly and conclusively authorized shall be paid over to the Trustee and converted into the General Fund as provided by law.

RESOLUTION 26-10

SECTION 3. BE IT FURTHER RESOLVED, that if any fee officials, as enumerated in Section 8-22-101, *Tennessee Code Annotated*, operate under provisions of Section 8-22 104 *Tennessee Code Annotated*, provisions of the preceding paragraph shall not apply to those particular officials.

SECTION 4. BE IT FURTHER RESOLVED, that any amendment to the budget, except for amendments to the budget for funds under supervision of the Director of Schools, shall be approved as provided in Section 5-9-407, *Tennessee Code Annotated*. The Director of Schools must receive approval of the Board of Education for transfers within each major category of the budget, and approval of both the Board of Education and the Board of County Commissioners for transfers between major categories as required by law. One copy of each amendment shall be filed with the County Clerk, one copy with the Chairman of the Finance Committee, and one with each divisional or departmental head concerned. The reason(s) for each transfer shall be clearly stated; however, this provision shall in no case whatsoever be construed as authorizing transfer from one fund to another, but shall apply solely to transfer within a certain fund.

SECTION 5. BE IT FURTHER RESOLVED, that any appropriations made by this resolution, which cover the same purpose for which a specific appropriation is made by statute is made in lieu of but not in addition to said statutory appropriation. The salary, wages, or remuneration of each officer, employee, or agent of the County shall not be in excess of the amounts authorized by existing law or as set forth in the estimate of expenditures which accompanies this resolution. Provided, however, that appropriations for such salaries, wages, or other remuneration hereby authorized shall in no case be construed as permitting expenditures for an office, agency, institution, division or department of the County in excess of the appropriation made herein for such office, agency, institution, division or department of the County. Such appropriation shall constitute the limit to the expenditures of any office, agency, institution, division or department for the year ending June 30, 2027. The aggregate expenditures for any item of appropriation shall in no instance be more than the amount herein appropriated for such item.

SECTION 6. BE IT FURTHER RESOLVED, that any resolution which may hereafter be presented to the Board of County Commissioners providing for appropriations in addition to those made by this Budget Appropriations Resolution shall specifically provide sufficient revenue or other funds actually to be provided during the fiscal year in which the expenditure is to be made to meet such additional appropriation. Said appropriating resolution shall be submitted to and approved by the State Director of Local Finance after its adoption as provided by Section 9-21-403, *Tennessee Code Annotated*.

SECTION 7. BE IT FURTHER RESOLVED, that the County Mayor and County Clerk are hereby authorized to borrow money on revenue anticipation notes, provided such notes are first approved by the State Director of Local Government Finance, to pay for the expenses herein authorized until the taxes and other revenue for the year 2026-2027 have been collected. The proceeds of loans for each individual fund shall not exceed 60% of the appropriations of each individual fund and shall be used only to pay the expenses and other requirements of the fund for which the loan is made. The loan shall be paid out of revenue from the fund for which money is borrowed. The notes evidencing the loans authorized under this section shall be issued under the applicable sections of Title 9, Chapter 21, *Tennessee Code Annotated*. Said notes shall be signed by the County Mayor and countersigned by the County Clerk and shall mature and be paid in full without renewal no later than June 30, 2027.

RESOLUTION 26-10

SECTION 8. BE IT FURTHER RESOLVED, that the delinquent County property taxes for the year 2025 and prior years and the interest and penalty thereon collected during the year ending June 30, 2027, shall be appropriated to the various County funds according to the subdivision of the tax levy for the year 2025. The Clerk and Master and the Trustee are hereby authorized and directed to make such apportionment accordingly.

SECTION 9. BE IT FURTHER RESOLVED, that all unencumbered balances of appropriations remaining at the end of the fiscal year shall lapse, and be of no further effect at the end of the year at June 30, 2027.

SECTION 10. BE IT FURTHER RESOLVED, that any resolution or part of a resolution which has heretofore been passed by the Board of County Commissioners which is in conflict with any provision in this resolution be and the same is hereby repealed.

SECTION 11. BE IT FURTHER RESOLVED, that this resolution shall take effect from and after its passage and its provisions shall be in force from and after July 1, 2026. This resolution shall be spread upon the minutes of the Board of County Commissioners.

Passed this 25th day of June, 2026.

Motion made by Commissioner _____

Seconded by Commissioner _____

Aye:

Nay:

Absent:

Pass:

Abstain:

Chairman

County Mayor

Attest:

County Clerk

RESOLUTION 26 - 11

A RESOLUTION MAKING APPROPRIATIONS TO NONPROFIT CHARITABLE AND CIVIC ORGANIZATIONS OF HAMBLLEN COUNTY, TENNESSEE FOR THE YEAR BEGINNING JULY 1, 2026 AND ENDING JUNE 30, 2027

WHEREAS, Section 5-9-109, *Tennessee Code Annotated*, authorizes the Hamblen County Legislative Body to make appropriations to various nonprofit charitable organizations and civic organizations, and

WHEREAS, the Hamblen County Legislative Body recognizes the various nonprofit charitable and civic organizations providing services in Hamblen County have great need of funds to carry on their nonprofit charitable and civic work, and

NOW, THEREFORE BE IT RESOLVED, by the Board of County Commissioners of Hamblen County, meeting in a regularly scheduled Commission meeting on the 25th day of June, 2026,

SECTION 1. That two million, one hundred sixty-six thousand, three hundred thirty-two dollars (\$2,166,332) be appropriated to nonprofit organizations in Hamblen County as reflected below:

Account #	Agency	Amount
General Fund Appropriations (#101):		
54310-316	North Hamblen County Volunteer Fire Department	\$ 80,000
54310-316	South Hamblen County Volunteer Fire Department	80,000
54310-316	East Hamblen County Volunteer Fire Department	80,000
54310-316	West Hamblen County Volunteer Fire Department	80,000
54490-316	Hamblen County Emergency Communications District	270,752
55110-309	Hamblen County Health Department – Local Direct	66,267
55120-312	Hamblen County Humane Society	300,000
55390-316	Hamblen County Health Department – Tennessee Dept. of Health	115,233
55590-316	Helen Ross McNabb - Youth Emergency Shelter (Y.E.S.)	2,800
55590-316	Morristown-Hamblen Child Care Center	12,500
56100-316	Senior Citizens Center – Adult Center	11,600
56300-316	Senior Citizens Center – Vital Visits	6,500
56500-316	Morristown-Hamblen Library	397,580
56900-316	Morristown Recreation Board	150,000
56900-316	Friends of Hospice	10,000
57300-316	Forest Service	1,000
58110-316	Morristown Area Chamber of Commerce – Tourism	22,500
58120-316	Joint Economic & Community Development Board of Hamblen County	91,000
73300-316	Imagination Library	5,000
91110-799	Morristown-Hamblen Library (Capital Improvements)	92,000
Opioid Abatement Fund Appropriations (#128):		
54490-316	Morristown-Hamblen Emergency Medical Services	50,000
55170-316	Helen Ross McNabb Center - New Hope Assessments	6,600
54250-399	Helen Ross McNabb Center - Women's Jail to Work Program	200,000
56900-316	Stepping Out Ministries	10,000
56900-316	Hamblen County Substance Abuse Coalition	25,000
		\$ 2,166,332

BE IT FURTHER RESOLVED, that all appropriations enumerated in Section 1 above are subject to the following conditions:

1. That the nonprofit and civic organizations to which funds are appropriated shall file with the County Clerk and the disbursing officials a copy of an annual report of its business affairs and transactions and the proposed use of the county's funds. Such annual report shall be prepared and certified by the chief financial officer of such nonprofit or civic organization in accordance with Section 5-9-109(c).

RESOLUTION 26 - 11

2. That said funds must only be used by the named nonprofit or civic organizations in furtherance of their nonprofit charitable or civic purposes benefiting the general welfare of the residents of Hamblen County.

3. That it is the expressed interest of the County Commission of Hamblen County in providing these funds to the above named nonprofit charitable or civic organizations to be fully in compliance with Section 5-9-109, Tennessee Code Annotated, and any and all other laws which may apply to county appropriations to nonprofit or civic organizations and so this appropriation is made subject to compliance with any and all of these laws and regulations.

BE IT FURTHER RESOLVED, that this resolution shall take effect from and after its passage and its provisions shall be in force from and after July 1, 2026. This resolution shall be spread upon the minutes of the Board of County Commissioners

Motion made by Commissioner _____

Seconded by Commissioner _____.

Aye:

Nay:

Absent:

Pass:

Abstain:

Chairman

County Mayor

Attest:

County Clerk

Hamblen County Government
Budget Committee
Monday, February 9, 2026
Hamblen County Courthouse – Large Courtroom

MINUTES

Members Present:

Rodney Long, Thomas Doty, Bobby Haun, Debbie A’Hearn, Jamie Carden, Edna Greene, Stan Harville, Tim Horner, Peggy Howell, Joe Huntsman, Sr. Wayne NeSmith, Mike Reed, Mike Richardson, Kyle Walker

Members Absent:

None

Call to Order

Chairman Rodney Long called the meeting to order at 5:24 p.m.

Visitors Wishing to Address the Committee

None

Old Business

None

New Business

- a. FY- 2026-2027 Preliminary Budget Plan of Action was presented by Finance Director Amanda Hale.
Motion (Stan Harville/Debbie A’Hearn, all in favor), to approve the Fiscal Year 2026/2027 Preliminary Budget Plan of Action Calendar.

Items of Interest

None

Adjournment

There being no further business Chairman Long adjourned the meeting at 5:29 p.m.

Hamblen County Government
Budget Committee
Monday, May 11, 2026
Hamblen County Courthouse – Large Courtroom

MINUTES

Members Present:

Rodney Long, Thomas Doty, Bobby Haun, Debbie A’Hearn, Jamie Carden, Edna Greene, Stan Harville, Tim Horner, Peggy Howell, Wayne NeSmith, Mike Reed, Mike Richardson, Kyle Walker

Members Absent:

Joe Huntsman, Sr.

Call to Order

Chairman Rodney Long called the meeting to order at 6:00 p.m.

Visitors Wishing to Address the Committee

Linda Noe

Old Business

None

New Business

- a. FY- 25/26 Budget Overview presented by Mayor Chris Cutshaw. See PowerPoint Presentation
No Action Taken

- b. Courtroom Security- Tab 31-Sheriff Chad Mullins and Executive Assistant Michelle Green presented the Courtroom Security Budget. Total Proposed Budget for FY 26/27 is \$1,428,683. Budget includes Evaluation and Testing-(Decrease), Maintenance Agreements, Transportation, Travel, Uniforms, In-Service Staff Development (Decrease) and Law Enforcement Equipment (Decrease).

- c. Sheriff’s Administration- Tab 32-Sheriff Chad Mullins and Executive Assistant Michelle Greene presented the Sheriff's Department Budget. Total Proposed Budget for FY 26/27 is \$4,636,414. Increases Data Processing Services and Other Contracted Services. Discussion concerning needed salary increases. Discussion Only.

- d. Special Patrols (SRO’s)- Tab 33- Sheriff Mullins and Executive Assistant Michelle Greene presented the SRO’s Budget. Total Proposed Budget for FY 26/27 is \$1,748,545. Increases in Law Enforcement Supplies, In-Service Staff Development, and Other Charges Categories.

- e. Sexual Offender Registry-Tab 34-Sheriff Chad Mullins and Executive Assistant Michelle Green presented the Sexual Offender Registry Budget for FY 26/27. Total Proposed Budget \$8,000. Increase of \$1,250-Travel and Other Equipment.

- f. Sheriff's Jail-Tab 35-Sheriff Chad Mullins and Executive Assistant Michelle Green presented the Sheriff's-Jail Budget. Total Proposed Budget for FY 26/27 is \$9,263,911. Main Budget Increase Cafeteria Personnel, State Retirement, Medical and Dental Services.
- f. Workhouse-Tab 36-Sheriff Chad Mullins and Executive Assistant Michelle Green presented the Workhouse Budget. FY26/27. Proposed Budget is \$127,415. No Increase.
- g. Civil Service Board-Tab 40-Sheriff Mullins and Executive Assistant Michelle Green presented the Civil Service Board Budget for FY 26/27. Proposed Budget is \$6,844.
- h. Drug Control Fund #122- Tab 60-Sheriff Chad Mullins and Executive Assistant Michelle Green presented the Proposed Budget for Narcotics. FY 26/27 Proposed Budget is \$262,965. No Change.

Items of Interest

None

Adjournment

There being no further business Chairman Long adjourned the meeting at 7:32 p.m.

Hamblen County Government
Budget Committee
Saturday, May 16, 2026
Hamblen County Courthouse – Large Courtroom

MINUTES

Members Present:

Rodney Long, Thomas Doty, Bobby Haun, Debbie A’Hearn, Jamie Carden, Edna Greene, Stan Harville, Tim Horner, Peggy Howell, Wayne NeSmith, Mike Reed, Mike Richardson, Kyle Walker

Members Absent:

Joe Huntsman, Sr.

Call to Order

Chairman Long called the meeting to order at 9:00 a.m.

Visitors Wishing to Address the Committee

Linda Noe, Tish Jones

Old Business

None

New Business

- a. School Department Presentation - Mr. Arnie Bunch, Director of Schools presented the Hamblen County Schools Budget for Fiscal Year 2026-2027. Mr. Bunch addressed the following:

- Lincoln Heights Elementary School Playground
- Lincoln Heights Middle School Completion
- Meadowview Middle School Completion
- Miller Boyd Cafeteria and Special Play Ground Equipment
- John Hay Elementary School
- School Resource Officer Program (SRO)
- School Nutrition Program and the 2026-2027 Plan of Action for Excess Fund Balance
- Federal Grants
- Comprehensive Coordinated Early Intervening Services
- General Fund Proposed Revenue Sources
- General Fund Proposed Expenditure Sources
- General Fund Proposed Expenditure Budget
- TISA Estimate
- Teacher Salaries \$50,000 in 2026-2027
- 2026-2027 Proposed Budget Summary
- Capital Projects
- 2026-2027 Proposed Capital Budget \$4,739,000
- County MOE \$27,356,092
- Sales Tax
- Projected 26-27 Available Fund Balance \$18,032,473
- 2026-2027 Proposed Budget Totals

General Fund	\$122,771,845
Federal Fund	\$6,671,822
School Nutrition Program	<u>\$16,168,056</u>
Total	\$145,611,723

- b. Keith Ely, Assessor of Property, presented the following General Fund Departments Budget:
 - Board of Equalization-Proposed Budget \$8,350
 - GIS-Proposed Budget \$108,847
 - Assessor of Property Proposed Budget \$508,009-Increase \$60,930
 - Reappraisal Program Proposed Budget \$186,242-Increase \$1,723
- c. Jeff Gardner, Administrator of Elections, presented the following General Fund Department Budget:
 - Election Commission-Proposed Budget 433,615- Increase of \$12,480
- d. Jim Clawson, Register of Deeds, presented the following General Funds Department Budget:
 - Register of Deeds Proposed Budget - \$473,973-Decrease Personnel and added Travel for the newly elected Register of Deeds.
- e. Tommy McKinney, Codes Enforcer-Manager presented the following General Fund Departments Budget:
 - Planning and Zoning -Proposed Budget \$294,026-Increase of \$4,065
 - Codes Compliance-Proposed Budget \$81,400-Increase of \$7,848
 - Storm Water Management-Proposed Budget \$99,882- Increase for Storm Water Engineer Contract
- f. Terry Myers, Maintenance Supervisor, presented the following General Fund Departments:
 - Maintenance- Proposed Budget \$1,587,782-Increase of \$340,512 Utilities for new JC, Electricity, Maintenance Agreements, Maintenance Personnell
- g. Scotty Long, Trustee-Proposed Budget \$506,604- Increase of 41,737-Medical Insurance, Premiums on Corporate Bonds
- h. Peggy Henderson-County Clerk Proposed Budget \$1,060,459- Increase of \$31,704-Medical Insurance
- i. Jeff Atkins-IT- Proposed Budget \$283,710- increase for Personnel and Data Processing Equipment
- j. Teresa West-Circuit Court Clerk-Proposed Budget \$1,252,959-Increase of \$13,270-Jury Fees and Other Items
- k. Judges Sempokowski and Collins, General SessionsGeneral Sessions Court- Court 1-Proposed Budget \$600,606 -Increase of \$110,562 Supervisor/Director Salary and Benefits

General Sessions Court -Court II- Proposed Budget \$273,993-Increase of \$6,239
- l. Teresa Carey-Clerk & Master-Proposed Budget \$483,737-Increase of \$14,458-Salary, Medical Insurance and Maintenance Agreements
- m. Cyndi Trent Doty, Juvenile Court-Proposed Budget \$407,394- Decrease of (\$1,681)

- n. Don Baird, Probation and Work Release Program- Proposed Budget:
 - o Probation Services-Proposes Budget \$324,698 Decrease of (\$1,858)
 - o Work Release Program-Proposed Budget \$466,676-Increase of \$8389
- o. Ricky Purkey, EMA Director-Proposed Budget \$190,729-Increase of \$23,062-Medical Insurance, Maintenance Agreements
- p. Greg Winstead-Animal Control-Proposed Budget \$458,986
- q. Daid King, Cherokee Park Manager-Proposed Budget 365,881
- r. Mannie Bedwell-UT AG Extension-Proposed Budget \$232,544
- s. Non Profit Organizations
For a Complete List of Requestors-See Area Organizations/Agencies/Requesting Contributions or Contractual Services (Non-Profit, Civic, etc.) Tab 58 in Budget
- t. Jeff Wisecarver-Highway and Sanitation

Sanitation Fund #116

Estimated Fund Balance 7/1/2026	\$2,995,257
Estimated Revenues	\$4,387,180
Expenditures	\$4,749,678
Estimated Fund Balance 6/30/2027	\$2,632,759

Highway/Public Works Fund #131

Estimated Fund Balance 7/1/2026	\$1,999,474
Estimated Revenues	\$3,051,736
Expenditures	\$3,587,120
Estimated Fund Balance 6/30/2027	\$1,464,565

Highway Capital Projects Fund #176

Estimated Fund Balance 7/1/2026	\$2,442,804
Estimated Revenues	\$3,300,000
Expenditures	\$563,000
Estimated Fund Balance 6/30/2027	\$5,159,804

- u. Amanda Hale, Finance Director, presented the following General Fund Departments Budget:
 - County Attorney-Proposed Budget \$36,303
 - Other General Administration-Proposed Budget \$16,500
 - Archives-Proposed Budget \$25,723
 - Finance-Proposed Budget \$671806
 - Other Public Safety-Proposed Budget \$98,000
 - Health Department-Proposed Budget \$1,657,300
 - Soil Conservation-Proposed Budget \$94,182
 - Veterans' Service-Proposed Budget \$41,666
 - Employee Benefits-Proposed Budget \$1,231,379
 - Capital Projects-Proposed Budget \$222,000

- v. Mayor Chris Cutshaw Proposed Budget for:
 - County Commission-Proposed Budget \$193,510
 - County Mayor-Proposed Budget \$284,648
 - Medical Examiner-Proposed Budget \$250,650
 - Tourism-Proposed Budget \$92,500

Items of Interest

None

Announcements

Upcoming Budget Meetings:

Monday, June 1, 2026

Thursday, June 4, 2026

Additional meetings may be scheduled

All budget Meetings will be held in the Large Courtroom of the Hamblen County Courthouse at 5:00 p.m.

Adjournment

There being no further business Chairman Long adjourned the meeting at 3:05 p.m.

Hamblen County Government
Budget Committee
Monday, June 1, 2026
Hamblen County Courthouse – Large Courtroom

MINUTES

Members Present:

Rodney Long, Bobby Haun, Debbie A’Hearn, Jamie Carden, Edna Greene, Stan Harville, Tim Horner, Peggy Howell, Wayne NeSmith, Mike Reed, Mike Richardson, Kyle Walker

Members Absent:

Thomas Doty, Joe Huntsman, Sr.
Bobby Haun-Left Early

Call to Order

Chairman Long called the meeting to order at 5:00 p.m.

Visitors Wishing to Address the Committee

None

Old Business

None

New Business

General Fund #101 Budgets

- a. County Commission-51100

Motion (Tim Horner/Bobby Haun to approve the Budget for County Commission-51100. Does not include COLA. Roll Call Vote was asked for by Chairman Long

	Aye	Nay	Pass	Abstain
Debbie A’Hearn	X			
Jamie Carden	X			
Thomas Doty	Absent			
Edna Greene		X		
Stan Harville	X			
Bobby Haun	X			
Tim Horner	X			
Peggy Howell		X		
Joe Huntsman	Absent			
Rodney Long	X			
Wayne NeSmith		X		
Mike Reed	X			
Mike Richardson	X			
Kyle Walker	X			

Total 9 Yes- 3 No- 2 Absent

Motion Passes

- b. Board of Equalization
Motion (Bobby Haun/Stan Harville, all in favor with 3 “No” Votes to include Edna Greene, Peggy Howell, Wayne NeSmith) to approve the Budget for Board of Equalization- 51210.
- c. County Mayor-51300
Motion (Bobby Haun/Debbie A’Hearn, all in favor) to approve the Budget for County Mayor-51300.
- d. County Attorney-51400
Motion (Bobby Haun/Stan Harville, all in favor with one “No” Vote from Edna Greene) to approve the Budget for County Attorney-51400.
- e. Election Commission-51500
Motion (Tim Horner/Debbie A’Hearn, all in favor) to approve the Budget for the Election Commission-51500.
- f. Register of Deeds-51600
Motion (Kyle Walker/Stan Harville, all in favor) to approve the Budget for Register of Deeds-51600.
- g. Planning and Zoning-51720
Motion (Bobby Haun/Jamie Carden, all in favor) to approve the Budget for Planning and Zoning-51720.
- h. Codes Compliance-51750
Motion (Bobby Haun/Tim Horner, all in favor) to approve the Budget for Codes Compliance-51750.
- i. GIS-51760
Motion (Kyle Walker/Jamie Carden, all in favor) to approve the Budget for GIS-51760.
- j. County Maintenance-51810
Motion (Bobby Haun/Debbie A’Hearn, all in favor) to approve the Budget for County Maintenance-51810.
- k. Other General Administration-51900
Motion (Debbie A’Hearn/Tim Horner, all in favor) to approve the Budget for Other General Administration-51900.
- l. Archives-51910
Motion (Bobby Haun/Stan Harville, all in favor) to approve the Budget for Archives-51910.
- m. Finance-52100
Motion (Kyle Walker/Peggy Howell, all in favor) to approve the Budget for Finance-52100.
- n. Assessor of Property-52300
Motion (Stan Harville/Peggy Howell, all in favor) to approve the Budget for Assessor of Property-52300.

- o. Reappraisal-52310
Motion (Jamie Carden/Kyle Walker, all in favor) to approve the Budget for Reappraisal-52310.

- p. Trustee-52400
Motion (Bobby Haun/Tim Horner, all in favor) to approve the Budget for Trustee-52400.

Motion (Mike Richardson/Peggy Howell, all in favor) to approve Hamblen County allowing Risk Management to insure the Trustee's Office and not purchasing a Surety Bond in the amount of \$3,500,000 for the Trustee saving the County \$20,000.

Motion (Amended by Bobby Haun/Mike Richardson) to use the County's Risk Management Insurance Company for Errors and Omissions for the Trustee's Office Insuring \$486,604.00.

	Aye	Nay	Pass	Abstain
Debbie A'Hearn	X			
Jamie Carden	X			
Thomas Doty	Absent			
Edna Greene	X			
Stan Harville	X			
Bobby Haun	X			
Tim Horner	X			
Peggy Howell	X			
Joe Huntsman	Absent			
Rodney Long	X			
Wayne NeSmith	X			
Mike Reed	X			
Mike Richardson	X			
Kyle Walker	X			

Total 12 Yes- 2 Absent
Motion Passes

- q. County Clerk-52500
Motion (Kyle Walker/Stan Harville, all in favor) to approve the Budget for County Clerk-52500.

- r. Data Processing-52600
Motion (Bobby Haun/Jamie Carden, all in favor) to approve the Budget for Data Processing-52600.

- s. Circuit Court-53100
Motion (Bobby Haun/Tim Horner, all in favor) to approve the Budget Circuit Court-53100.

- t. General Sessions I-53300
Motion (Kyle Walker/Stan Harville, all in favor) to approve the Budget for General Sessions I-53300.

- u. General Sessions II-53300
Motion (Stan Harville/Kyle Walker, all in favor) to approve the Budget for General Sessions II-53300.
- v. Drug Court-53330
Motion (Stan Harville/Tim Horner, all in favor) to approve the Budget for Drug Court-53330.
- w. Clerk & Master-53400
Motion (Kyle Walker/Tim Horner, all in favor) to approve the Budget for Clerk & Master-53400.
- x. Juvenile Court-53500
Motion (Tim Horner/Stan Harville, all in favor) to approve the Budget for Juvenile Court-53500.
- Y Courtroom Security-53920
Motion (Jamie Carden/Debbie A'Hearn, all in favor) to approve the Budget for Courtroom Security-53920.
- z. Hamblen County Sheriff's Department-54110
Motion (Kyle Walker/Bobby Haun, all in favor) to approve the Budget for the Hamblen County Sheriff's Department-54110.
- aa. Special Patrol's-SRO-54120
Motion (Stan Harville/Kyle Walker, all in favor) to approve the Budget for Special Patrol's-SRO-54120.
- bb. Sexual Offender Registry-54160
Motion (Tim Horner/Debbie A'Hearn, all in favor) to approve the Budget for Sexual Offender Registry-54160.
- cc. Jail-54210
Motion (Kyle Walker/Debbie A'Hearn, all in favor) to approve the Budget for the Jail-54210.
- dd. Workhouse-54220
Motion (Tim Horner/Jamie Carden, all in favor) to approve the Budget for the Workhouse-54220.
- ee. Work Release Program-54250
Motion (Bobby Haun/Kyle Walker, all in favor) to approve the Budget for the Work Release Program-54250.
- ff. EMA & Homeland Security Grant-54410 & 54900
Motion (Tim Horner/Debbie A'Hearn, all in favor) to approve the Budget for EMA & Homeland Security Grant-5441- & 54900.

- gg. Civil Service Board-54510
Motion (Tim Horner/Debbie A’Hearn, all in favor) to approve the Budget for Civil Service Board-54510.
- hh. Medical Examiner-54610
Motion (Jamie Carden/Tim Horner, all in favor) to approve the Budget for Medical Examiner-54610.
- ll. Drug Court Expansion-54710
Motion (Kyle Walker/Stan Harville, all in favor) to approve the Budget for Drug Court Expansion-54710.
- jj. Other Public Safety-54900
Motion (Tim Horner/Debbie A’Hearn, all in favor) to approve the Budget for Other Public Safety-54900.
- kk. Health Department-55110
Motion (Stan Harville/Kyle Walker, all in favor) to approve the Budget for the Health Department-55110.
- ll. Animal Control-55120
Motion (Tim Horner/Jamie Carden, all in favor with No Votes from Edna Green Peggy Howell, Wayne NeSmith) to approve the Budget for Animal Control-55120
- mm. Contracts with Gov Agencies-55710-55900
Motion (Tim Horner/Kyle Walker, all in favor) to approve the Budget for Contracts with Gov Agencies-55710-55900.
- nn. Cherokee Park-56700
Motion (Stan Harville/Jamie Carden, all in favor) to approve the Budget for Cherokee Park-56700.
- oo. UT Extension
Motion (Stan Harville/Tim Horner, all in favor) to approve the Budget for UT Extension-57100.
- pp. Soil Conservation Service-57500
Motion (Peggy Howell/Debbie A’Hearn, all in favor with Rodney Long Abstaining with Cause) to approve the Budget Soil Conservation Service-57500.
- qq. Storm Water Management-57800
Motion (Kyle Walker/Stan Harville, all in favor)to approve the Budget for Storm Water Management-57800.
- rr. Tourism
Motion (Tim Horner/Stan Harville, all in favor with “No” Votes from Edna Green and Wayne NeSmith) to approve the Budget for Tourism-58110.

- ss. Industrial Development-58120
Motion (Stan Harville/Tim Horner, all in favor with "No" Votes from Edna Green and Wayne NeSmith) to approve the Budget for Industrial Development-58120. This Budget also includes the \$91,000 to the Joint Economic & Community Development Board (Non-Profit).
- tt. Other Economic & Community Development-58190
No Action Taken-No Budget
- uu. Veterans Services-58300
Motion (Peggy Howell/Kyle Walker, all in favor) to approve the Budget for Veterans Services-58300.
- vv. Employee Benefits-58600
Motion (Tim Horner/Kyle Walker, all in favor) to approve the Budget for Employee Benefits-58600.
- ww. Miscellaneous
Motion (Stan Harville/Tim Horner/Bobby Haun, all in favor) to approve the Budget for Miscellaneous-58900.
- xx. Capital Projects-91110

Reroofing of Courthouse and Striping the Parking Lot
Motion (Debbie A'Hearn/Kyle Walker, all in favor) to approve the Budget for Re-roofing the Courthouse and Striping the Parking Lot.

HVAC Units \$40,000
Motion (Tim Horner/Peggy Howell, all in favor) to approve the Budget for HVAC Units.

3 Vehicles HCSO \$174,000
Motion (Kyle Walker/Mike Reed, all in favor) to approve the Budget for 3 Vehicles For the Hamblen County Sheriff's Department.
- zz. Sanitation Fund #116
Motion (Tim Horner/Kyle Walker, all in favor) to approve the Budget for Sanitation Fund #116. Commissioner Peggy Howell had a presentation on Convenience Centers.
- aaa. Highway Fund #131
Motion (Debbie A'Hearn/Jamie Carden, all in favor with Mike Richardson Abstaining With Cause) to approve the Budget for the Highway Fund #131.
- bbb. Drug Control Fund #122
Motion (Stan Harville/Tim Horner, all in favor) to approve the Budget for Drug Control Fund #122.
- ccc. Debit Service Fund #151
Motion (Tim Horner/Stan Harville, all in favor) to approve the Budget for Debt Service Fund #151.

- ddd. Special Debt Service Fund #154
Motion (Kyle Walker/Peggy Howell, all in favor) to approve the Budget for Special Debt Service Fund #154.
- eee. Highway Capital Projects
Motion (Stan Harville/Debbie A' Hearn, all in favor with Mike Richardson Abstaining with Cause) to approve Highway Capital Projects #176.

Items of Interest

None

Announcements

- a. Upcoming Budget Meetings
- Thursday, June 4, 2026
 - June 25, 2026 HCLB Commission Meeting
Adopt Budget Including:
 1. Tax Levy Resolution
 2. Appropriations Resolution
 3. Resolution Making Appropriations to Nonprofits, Charitable and Civic Organizations

Adjournment

There being no further business Chairman Long adjourned the meeting at 7:06 p.m.

Hamblen County Government

Finance Committee

Monday, June 15, 2026

Hamblen County Courthouse – Large Courtroom

MINUTES

Members Present:

Rodney Long, Thomas Doty, Bobby Haun, Debbie A’Hearn, Stan Harville, Peggy Howell, Mike Reed, Mike Richardson, Kyle Walker

Members Absent:

Joe Huntsman, Sr.

Call to Order

Chairman Rodney Long called the meeting to order at 5:06 p.m.

Visitors Wishing to Address the Committee

Gwen Holden, Linda Noe, Dennis Greene

Recurring Business

- a. Expenditure Reports –May 2026 (Information Only - No Action Necessary)
- b. Revenue Summary Report-May 2026 (Information Only-No Action Necessary)
- c. Monthly Checks -May 2026 (Information Only - No Action Necessary)

Old Business

- a. None

New Business

- a. Resolution 26-__ -A Resolution Authorizing the Hamblen County Sheriff's Office to Apply for the Statewide School Resource Officer (SRO) Program Grant in the Amount of \$1,320,000.00
Motion (Stan Harville/Debbie A’Hearn, all in favor) to approve Resolution 26-__ - A Resolution Authorizing the Hamblen County Sheriff's Office to Apply for the Statewide School Resource Officer (SRO) Program Grant in the Amount of \$1,320,000.00
- b. Banking Contract
Scotty Long, Trustee will Bring the Bid Results for the New 3-Year Banking Contract to the County Commission Meeting on June 25, 2026 for Approval
Motion (Thomas Doty/Mike Reed, all in favor) to approve the Banking Contract at the County Commission Meeting on June 25, 2026.
- c. Amending Private Act-Private Chapter No. 57 House Bill No. 2640 Senate Bill No. 2705 114th General Assembly Section 2 the Hamblen County, Tennessee, Road Commission is Abolished Effective August 31, 2028
Motion (Thomas Doty/Kyle Walker, all in favor) to approve Amending Private Act-Private Chapter No. 57 House Bill No. 2640 Senate Bill No. 2705 114th General Assembly Section 2 the Hamblen County, Tennessee, Road Commission is Abolished Effective August 31, 2028 (For full description see Private Act Chapter No.57

- d. Amending Private Act-Private Chapter No. 58 House Bill No. 6242 Senate Bill No. 2703 114th General Assembly for County Attorney Section 1-County Attorney at the September Meeting Designated for Election of County Attorney. Section 3 The County Attorney for Services Shall be Paid on Annual Retainer Fee of \$1,200. For Legal Services Performed on Behalf of County, the County Attorney Shall be Entitled to Receive Additional Reasonable Compensation and Reimbursement for Actual Expenses Incurred. (for full description see Private Chapter No. 58)
Motion (Debbie A’Hearn/Mike Richardson, all in favor) to approve Amending Private Act-Private Chapter No. 58 House Bill No. 6242 Senate Bill No. 2703 114th General Assembly for County Attorney Section 1-County Attorney at the September Meeting Designated for Election of County Attorney. Section 3 The County Attorney for Services Shall be Paid on Annual Retainer Fee of \$1,200. For Legal Services Performed on Behalf of County, the County Attorney Shall be Entitled to Receive Additional Reasonable Compensation and Reimbursement for Actual Expenses Incurred. (for full description see Private Chapter No. 58)
- e. MetTel Communications Solution
Motion (Thomas Doty/Stan Harville, all in favor) to approve the MetTel Communications Solution Contract Renewal for the telephone system
- f. Annual Debt Report for Year Ending June 30, 2026
The Annual Debt Report for Year Ending June 30, 2026 was presented by Amanda Hale, Finance Director. Total Debt indicated in the report as of 6/30/26 is \$134,535,388. Bond Ratings indicate a Very Strong Credit Worthiness and a High Grade Investment Value. The percentage of Outstanding Balance Related to Hamblen County School Department is 30.60% with the rest related to Hamblen County General Government.
Motion (Debbie A’Hearn/Mike Reed, all in favor) to approve the Annual Debt Report for Year Ending June 30, 2026
- g. Construction Change Directive #04- \$5,059
Motion (Mike Richardson/Stan Harville, all in favor of approving the Construction Change Directive #04- \$5,059
- h. Budget Amendments
- i. Hamblen County Department of Education Budget Amendment #11 Increase of \$189,541.65
Motion (Stan Harville/Thomas Doty, all in favor) to approve the Budget Amendment #11 from the Hamblen County Department of Education Increase of \$189,541.65
 - ii. Fund #101- General Fund- Multiple Categories
Motion (Mike Richardson/Stan Harville, all in favor) to approve Fund #101- General Fund- Multiple Categories
 - iii. Fund #116- Solid Waste/Sanitation Fund \$37,100
Motion (Stan Harville/Debbie A’Hearn, all in favor) to approve Fund #116- Solid Waste/Sanitation Fund for \$37,100

- iv. Fund #128- Drug Use Abatement Fund \$360,288.76
Motion (Mike Reed/Kyle Walker, all in favor) to approve Fund #128 for \$360,288.76
- v. Fund #131- Highway Department Fund \$24,300
Motion (Stan Harville/Debbie A'Hearn, all in favor) to approve Fund #131 for \$24,300
- vi. Fund #151- General Debt Service Fund \$282,000
Motion (Kyle Walker/Thomas Doty, all in favor) to approve Fund #151 for \$282,000
- vii. Fund #154- Special Debt Service Fund \$151,800
Motion (Debbie A'Hearn/Peggy Howell, all in favor) to approve Fund #154 for \$151,800
- viii. Fund #176- Highway Capital Projects Fund \$20,000
Motion (Stan Harville/Thomas Doty, all in favor) to approve Fund #176 for \$20,000
- i. Construction Change Directive No. 08 Lump Sum unchanged \$0.00
Motion (Mike Richardson/Peggy Howell, all in favor) to approve Construction Change Directive No. 08 Lump Sum unchanged \$0.00

Items of Interest (No Action Necessary)

- a. Planning Commission Building Permit Report-May 2026
- b. County Attorney Invoices-May 2026
- c. Trustee Report-May 1, 2026-May 31, 2026
- d. Morristown-Hamblen Emergency Medical Service Board of Directors Meeting Report
April 22, 2026
- e. Hamblen County Department of Education Quarterly Expenditure Report Third Quarter 2025-26

Adjournment - There being no further business, Chairman Long adjourned the Finance Committee Meeting at 5:39 p.m.



Hamblen County Government
FINANCE COMMITTEE

Monday, June 15, 2026

Immediately Following adjournment of the Justice Center/Public Safety Committee
Large Courtroom – Hamblen County Courthouse

FINANCE COMMITTEE

AGENDA

Rodney Long
Chairman

1. **Call to Order**-*Chairman Rodney Long*

Thomas Doty
Vice-Chairman

2. **Visitors Wishing to Address the Committee About Agenda Items Only** –
Chairman Rodney Long (Visitors will be allotted 3 minutes to speak)

Bobby Haun
Ex-Officio

3. **Recurring Business** – *Chairman Rodney Long*

- a. Expenditure Reports – May 2026 (*Information Only-No Action Necessary*)
- b. Revenue Summary Report-May 2026 (*Information Only-No Action Necessary*)
- c. Monthly Checks- May 2026 (*Information Only-No Action Necessary*)

Debbie A’Hearn
Member

4. **Old Business** – *Chairman Rodney Long*

- a. None

Stan Harville
Member

5. **New Business** – *Chairman Rodney Long*

Peggy Howell
Member

- a. Resolution 26-__-A Resolution Authorizing the Hamblen County Sheriff’s Office to Apply for the Statewide School Resource Officer (SRO) Program Grant in the Amount of \$1,350,000.00-*Sheriff Chad Mullins*
- b. Banking Contract HomeTrust Bank-*Scotty Long Trustee*
- c. Amending Private Act-Private Chapter No. 57 House Bill No. 2640 Senate Bill No. 2705 114th General Assembly Section 2 the Hamblen County, Tennessee, Road Commission is Abolished Effective August 31, 2028. Should a Vacancy on the Road Commission Occur Prior to August 31, 2028, the Vacancy Shall not be Filled for the Remainder of the Unexpired Term. (for full description see Private Chapter No. 57)-*County Mayor Chris Cutshaw*
- d. Amending Private Act-Private Chapter No. 58 House Bill No. 6242 Senate Bill No. 2703 114th General Assembly for County Attorney Section 1- County Attorney Shall be Elected by the Hamblen County Commission Annually at the September Meeting Designated for Election of County Attorney. Section 3 The County Attorney for Services Shall be Paid on Annual Retainer Fee of \$1,200. For Legal Services Performed on Behalf of County, the County Attorney Shall be Entitled to Receive Additional Reasonable Compensation and Reimbursement for Actual Expenses Incurred. (for full description see Private Chapter No. 58)-*County Mayor Chris Cutshaw*
- e. MetTel Communications Solution Contract-*Jeff Atkins IT Manager*
- f. Annual Debt Report for Year Ending June 30, 2026-*Amanda Hale, Finance Director*
- g. Construction Change Directive #04- \$5,059-*County Mayor Chris Cutshaw*
- h. Budget Amendments -*Amanda Hale, Finance Director and Hamblen County Board of Education Supervisor Jared Ladd*
 - i. Hamblen County Department of Education Budget Amendment # 11 Increase of \$189,541.65
 - ii. Fund #101-General Fund-Multiple Categories (see attached)

Joe Huntsman, Sr.
Member

Mike Reed
Member

Mike Richardson
Member

Kyle Walker
Member

- iii. Fund #116-Solid Waste/Sanitation Fund \$37,100
- iv. Fund #128-Drug Use Abatement Fund \$360,288.76
- v. Fund #131-Highway Department Fund \$24,300
- vi. Fund #151-General Debt Service Fund \$282,000
- vii. Fund #154-Special Debt Service \$151,800
- viii. Fund #176-Highway Capital Projects Fund \$20,000
- i. Construction Change Directive No. 08 Lump Sum unchanged \$0.00

6. Items of Interest (No Action Necessary) – Chairman Rodney Long

- a. Planning Commission Building Permits-April 2026
- b. County Attorney Invoices -April 2026
- c. Trustee Report-April 1, 2026-April 30, 2026
- d. Morristown-Hamblen Emergency Medical Service Board of Directors Meeting Report March 25, 2026
- e. Hamblen County Department of Education Quarterly Expenditure Report Third Quarter 2025-26

7. Adjournment – Chairman Rodney Long

EXPENDITURE REPORTS

EXPENSE SUMMARY REPORT

May 2025-2026

HAMBLLEN COUNTY ACCOUNTS & BUDGETS

Fund(s) Selected:

101 General Fund

101

Account Group	Budget Amount	Budget Amendments	Amended Budget	MTD Expenses	YTD Expenses	Outstanding Encumbrances	Unencumbered Balance	% Bgdt Remain
51100 County Commission	202,376.00	0.00	202,376.00	11,422.51	141,463.71	29,693.48	31,218.81	15.43%
51210 Board Of Equalizaton	8,350.00	0.00	8,350.00	0.00	0.00	0.00	8,350.00	100.00%
51300 County Mayor/Executive	275,305.00	0.00	275,305.00	21,389.43	240,986.90	5,003.30	29,314.80	10.65%
51400 County Attorney	36,303.00	0.00	36,303.00	26,563.26	47,081.86	0.00	-10,778.86	-29.69%
51500 Election Commission	433,615.00	0.00	433,615.00	65,151.93	362,093.47	10,434.45	61,087.08	14.09%
51600 Register Of Deeds	474,656.00	0.00	474,656.00	37,173.54	393,684.17	5,808.55	75,163.28	15.84%
51720 Planning	289,961.00	0.00	289,961.00	19,785.87	212,003.56	1,768.36	76,189.08	26.28%
51750 Codes Compliance	73,552.00	0.00	73,552.00	6,236.37	62,073.01	0.00	11,478.99	15.61%
51760 Geographical Information Systems	108,603.00	0.00	108,603.00	5,740.74	89,726.05	0.00	18,876.95	17.38%
51810 Other Facilities	1,247,270.00	25,800.00	1,273,070.00	92,415.28	1,013,368.55	23,344.78	236,356.67	18.57%
51900 Other General Administration	16,500.00	0.00	16,500.00	0.00	11,500.00	0.00	5,000.00	30.30%
51910 Preservation Of Records	25,709.00	0.00	25,709.00	1,962.00	20,187.37	740.93	4,780.70	18.60%
52100 Accounting And Budgeting	656,992.00	29,235.00	686,227.00	-48,853.99	535,498.56	313.67	150,414.77	21.92%
52300 Property Assessor's Office	447,079.00	0.00	447,079.00	34,223.98	387,866.82	3,898.87	55,313.31	12.37%
52310 Reappraisal Program	184,519.00	0.00	184,519.00	41,187.89	92,546.12	114.80	91,858.08	49.78%
52400 County Trustee's Office	464,867.00	0.00	464,867.00	36,163.91	402,232.77	3,688.70	58,945.53	12.68%
52500 County Clerk's Office	1,028,755.00	35,000.00	1,063,755.00	76,163.52	810,070.21	11,369.22	242,315.57	22.78%
52600 Data Processing	193,417.00	47,416.08	240,833.08	48,883.56	186,389.50	19,190.88	35,252.70	14.64%
53100 Circuit Court	1,239,689.00	3,400.00	1,243,089.00	89,189.25	1,037,341.59	6,818.14	198,929.27	16.00%
53300 General Sessions Court	757,798.00	37,835.00	795,633.00	65,345.04	670,668.40	859.08	124,105.52	15.60%
53330 Drug Court	235,664.00	18,905.96	254,569.96	17,984.72	207,038.28	2,834.10	44,697.58	17.56%
53400 Chancery Court	469,279.00	0.00	469,279.00	31,152.11	362,703.22	22,104.21	84,471.57	18.00%
53500 Juvenile Court	409,075.00	0.00	409,075.00	25,654.13	272,657.36	3,542.54	132,875.10	32.48%
53900 Other Admin Of Justice - Mental Health	186,830.00	0.00	186,830.00	9,186.74	102,962.69	7,344.72	76,522.59	40.96%

EXPENSE SUMMARY REPORT

May 2025-2026

HAMBLLEN COUNTY ACCOUNTS & BUDGETS

101 General Fund

Fund(s) Selected:

101

Account Group	Budget Amount	Budget Amendments	Amended Budget	MTD Expenses	YTD Expenses	Outstanding Encumbrances	Unencumbered Balance	% Bgdt Remain
53910 Probation Services	326,556.00	0.00	326,556.00	23,061.66	243,344.28	2,357.71	80,854.01	24.76%
53920 Courtroom Security	1,435,218.00	6,000.00	1,441,218.00	122,094.89	1,221,096.09	5,265.96	214,855.95	14.91%
53930 Victim Assistance Program	0.00	0.00	0.00	0.00	0.00	0.00	0.00	
54110 Sheriff's Department	6,247,531.00	-1,606,058.38	4,641,472.62	317,605.70	3,490,951.55	204,453.67	946,067.40	20.38%
54120 Special Patrols	0.00	1,677,080.07	1,677,080.07	132,969.40	1,792,548.38	5,508.41	-120,976.72	-7.21%
54160 Administration Of The Sexual Offender	6,750.00	0.00	6,750.00	0.00	5,277.10	0.00	1,472.90	21.82%
54210 Jail	9,005,240.00	25,451.81	9,030,691.81	669,267.87	6,940,736.89	204,108.80	1,885,846.12	20.88%
54220 Workhouse	131,309.00	0.00	131,309.00	5,043.58	54,919.64	0.00	76,389.36	58.18%
54250 Work Release Program	458,287.00	0.00	458,287.00	219,661.32	416,545.37	4,494.48	37,247.15	8.13%
54310 Fire Prevention And Control	300,000.00	0.00	300,000.00	0.00	300,000.00	0.00	0.00	0.00%
54410 Civil Defense	167,667.00	0.00	167,667.00	14,011.08	148,248.78	2,559.47	16,858.75	10.05%
54490 Other Emergency Management	334,880.00	0.00	334,880.00	0.00	344,644.00	0.00	-9,764.00	-2.92%
54510 Inspection And Regulation	6,844.00	0.00	6,844.00	484.44	5,328.84	0.00	1,515.16	22.14%
54610 Medical Examiner	247,540.00	0.00	247,540.00	12,907.14	119,818.09	4,543.56	123,178.35	49.76%
54710 Drug Court Expansion - Public Safety Grant	366,437.00	0.00	366,437.00	31,226.13	260,700.40	59,964.33	45,772.27	12.49%
54900 Other Public Safety	24,000.00	0.00	24,000.00	0.00	15,454.00	0.00	8,546.00	35.61%
55110 Local Health Center	1,477,888.00	0.00	1,477,888.00	66,241.01	745,776.36	10,844.72	721,266.92	48.80%
55120 Rabies And Animal Control	457,369.00	0.00	457,369.00	38,287.46	404,970.59	2,323.95	50,074.46	10.95%
55140 Nursing Home	7,000.00	0.00	7,000.00	0.00	7,000.00	0.00	0.00	0.00%
55170 Alcohol And Drug Programs	6,400.00	0.00	6,400.00	0.00	6,400.00	0.00	0.00	0.00%
55390 Appropriation To State	115,233.00	0.00	115,233.00	0.00	0.00	0.00	115,233.00	100.00%
55520 Aid To Dependent Children	10,000.00	0.00	10,000.00	0.00	10,000.00	0.00	0.00	0.00%
55590 Other Local Welfare Services	27,700.00	0.00	27,700.00	85.00	26,275.00	0.00	1,425.00	5.14%
55710 Sanitation Management	21,710.00	0.00	21,710.00	7,140.00	7,245.86	0.00	14,464.14	66.62%

EXPENSE SUMMARY REPORT

May 2025-2026

HAMBLLEN COUNTY ACCOUNTS & BUDGETS

101 General Fund

Fund(s) Selected:

101

Account Group	Budget Amount	Budget Amendments	Amended Budget	MTD Expenses	YTD Expenses	Outstanding Encumbrances	Unencumbered Balance	% Bgd Remain
55900 Other Public Health And Welfare	95,000.00	0.00	95,000.00	0.00	42,178.11	0.00	52,821.89	55.60%
56100 Adult Activities	11,600.00	0.00	11,600.00	0.00	11,600.00	0.00	0.00	0.00%
56300 Senior Citizens Assistance	6,500.00	0.00	6,500.00	0.00	6,500.00	0.00	0.00	0.00%
56500 Libraries	386,000.00	0.00	386,000.00	96,500.00	386,000.00	0.00	0.00	0.00%
56700 Parks And Fair Boards	370,681.00	57,320.90	428,001.90	75,155.50	334,362.73	9,915.35	83,723.82	19.56%
56900 Other Social, Cultural And Recreational	271,000.00	0.00	271,000.00	0.00	271,000.00	0.00	0.00	0.00%
57100 Agricultural Extension Service	232,544.00	0.00	232,544.00	41,000.72	145,445.79	5,500.00	81,598.21	35.09%
57300 Forest Service	1,000.00	0.00	1,000.00	0.00	1,000.00	0.00	0.00	0.00%
57500 Soil Conservation	93,614.00	0.00	93,614.00	7,590.30	82,600.01	0.00	11,013.99	11.77%
57800 Storm Water Management	94,744.00	0.00	94,744.00	14,593.24	80,634.93	328.58	13,780.49	14.54%
58110 Tourism	77,500.00	0.00	77,500.00	150.00	84,507.24	56,040.86	-63,048.10	-81.35%
58120 Industrial Development	698,000.00	0.00	698,000.00	0.00	649,590.67	0.00	48,409.33	6.94%
58190 Other Economic And Community D	0.00	0.00	0.00	0.00	165,734.49	0.00	-165,734.49	
58300 Veterans' Services	41,455.00	0.00	41,455.00	3,132.09	33,549.27	17.30	7,888.43	19.03%
58600 Employee Benefits	1,091,844.00	0.00	1,091,844.00	462.50	858,669.55	0.00	233,174.45	21.36%
58900 Miscellaneous	386,300.00	0.00	386,300.00	121.47	501,719.27	62,000.00	-177,419.27	-45.93%
73300 Community Services	5,000.00	0.00	5,000.00	0.00	5,000.00	0.00	0.00	0.00%
91110 General Administration Projects	342,000.00	250,310.00	592,310.00	26,447.09	417,225.29	0.00	175,084.71	29.56%
91120 Administration Of Justice Projects	0.00	0.00	0.00	0.00	0.00	0.00	0.00	
91130 Public Safety Projects	114,000.00	0.00	114,000.00	0.00	114,002.20	57,051.61	-57,053.81	-50.05%
91140 Public Health And Welfare Projects	0.00	0.00	0.00	235,471.03	3,656,654.70	136,923.49	-3,793,578.19	
91150 Social, Cultural And Recreation Projects	30,000.00	7,875.00	37,875.00	0.00	0.00	36,536.00	1,339.00	3.54%
91190 Other General Government Proje	85,000.00	0.00	85,000.00	0.00	0.00	0.00	85,000.00	100.00%
91200 Highway And Street Capital Projects	0.00	0.00	0.00	0.00	0.00	0.00	0.00	

EXPENSE SUMMARY REPORT

May 2025-2026

HAMBLÉN COUNTY ACCOUNTS & BUDGETS

101 General Fund

Fund(s) Selected:

101

Account Group	Budget Amount	Budget Amendments	Amended Budget	MTD Expenses	YTD Expenses	Outstanding Encumbrances	Unencumbered Balance	% Bdgt Remain
99100 Transfers Out	600,000.00	0.00	600,000.00	0.00	600,000.00	0.00	0.00	0.00%
General Fund #(101)	<u>35,681,505.00</u>	<u>615,571.44</u>	<u>36,297,076.44</u>	<u>2,874,832.41</u>	<u>32,677,399.64</u>	<u>1,029,611.03</u>	<u>2,590,065.77</u>	<u>7.14%</u>

EXPENSE SUMMARY REPORT

May 2025-2026

HAMBLEN COUNTY ACCOUNTS & BUDGETS

Fund(s) Selected:

116 Sanitation

116

Account Group	Budget Amount	Budget Amendments	Amended Budget	MTD Expenses	YTD Expenses	Outstanding Encumbrances	Unencumbered Balance	% Bdgt Remain
55710 Sanitation Management	4,522,964.00	50,002.20	4,572,966.20	266,124.29	3,330,878.43	150,397.83	1,091,689.94	23.87%
99100 Transfers Out	0.00	0.00	0.00	0.00	0.00	0.00	0.00	
Solid Waste/Sanitation Fund #(116)	4,522,964.00	50,002.20	4,572,966.20	266,124.29	3,330,878.43	150,397.83	1,091,689.94	23.87%

EXPENSE SUMMARY REPORT

May 2025-2026

HAMBLLEN COUNTY ACCOUNTS & BUDGETS

131 Highway

Fund(s) Selected:

131

Account Group	Budget Amount	Budget Amendments	Amended Budget	MTD Expenses	YTD Expenses	Outstanding Encumbrances	Unencumbered Balance	% Bdgt Remain
61000 Administration	519,228.00	0.00	519,228.00	32,024.91	446,238.39	10,020.80	62,968.81	12.13%
62000 Highway And Bridge Maintenance	1,941,456.00	0.00	1,941,456.00	108,019.30	1,272,254.89	70,160.24	599,040.87	30.86%
63100 Operation And Maintenance Of Equipment	657,793.00	0.00	657,793.00	30,941.33	326,531.84	137,234.72	194,026.44	29.50%
66000 Employee Benefits	25,931.00	0.00	25,931.00	0.00	22,368.71	0.00	3,562.29	13.74%
68000 Capital Outlay	29,500.00	0.00	29,500.00	0.00	2,393.00	0.00	27,107.00	91.89%
99100 Transfers Out	0.00	0.00	0.00	0.00	0.00	0.00	0.00	
Highway/Public Works Fund (#131)	<u>3,173,908.00</u>	<u>0.00</u>	<u>3,173,908.00</u>	<u>170,985.54</u>	<u>2,069,786.83</u>	<u>217,415.76</u>	<u>886,705.41</u>	<u>27.94%</u>

REVENUE SUMMARY REPORTS

REVENUE SUMMARY REPORT

May 2025-2026

HAMBLEN COUNTY ACCOUNTS & BUDGETS

101 General Fund

Fund(s) Selected:
101; 122; 128; 151; 154;
171; 173; 176; 177; 178;

Fd	Acct	Obj	Loc	Prg	Description	Budget Amount	Budget Amendments	Amended Budget	MTD Revenues	YTD Revenues	Uncollected Revenues	% of Bdgt
10	40110	000	00000	000	Current Property Tax	20,332,479.00	0.00	20,332,479.00	499,596.06	20,399,142.65	-66,663.65	100.3%
10	40115	000	00000	000	Discount On Property Taxes	607,000.00	0.00	607,000.00	0.00	564,176.58	42,823.42	92.94%
10	40120	000	00000	000	Trustee's Collections - Prior Year	260,000.00	0.00	260,000.00	10,441.04	389,000.42	-129,000.42	149.6%
10	40125	000	00000	000	Trustee Collections - Bankruptcy	1,200.00	0.00	1,200.00	100.23	3,106.39	-1,906.39	258.8%
10	40130	000	00000	000	Circuit Clerk/Clerk & Master Collections-Prior Yrs	75,000.00	0.00	75,000.00	11,410.13	52,445.02	22,554.98	69.92%
10	40140	000	00000	000	Interest And Penalty	85,000.00	0.00	85,000.00	22,023.66	105,291.66	-20,291.66	123.8%
10	40161	000	00000	000	Payments In Lieu Of Taxes - T.V.A.	1,234.00	0.00	1,234.00	0.00	0.00	1,234.00	0.000%
10	40162	000	00000	000	Payments In Lieu Of Taxes - Local Utilities	173,000.00	0.00	173,000.00	21,321.97	242,711.77	-69,711.77	140.2%
10	40163	000	00000	000	Payments In Lieu Of Taxes - Other	60,000.00	0.00	60,000.00	0.00	64,636.81	-4,636.81	107.7%
10	40210	000	00000	000	Local Option Sales Tax	17,000.00	0.00	17,000.00	1,477.73	14,777.30	2,222.70	86.92%
10	40220	000	00000	000	Hotel/Motel Tax	19,000.00	0.00	19,000.00	2,332.06	24,156.27	-5,156.27	127.1%
10	40240	000	00000	000	Wheel Tax	0.00	0.00	0.00	0.00	0.00	0.00	100.0%
10	40250	000	00000	000	Litigation Tax - General	120,000.00	0.00	120,000.00	0.00	0.00	120,000.00	0.000%
10	40250	000	05310	000	Litigation Tax - General - Circuit Court One (1)	0.00	0.00	0.00	954.82	9,340.87	-9,340.87	100.0%
10	40250	000	05330	000	Litigation Tax - General - General Sessions One (1)	0.00	0.00	0.00	12,466.90	117,647.86	-117,647.86	100.0%
10	40250	000	05340	000	Litigation Tax - General - Chancery Court	0.00	0.00	0.00	1,284.52	11,029.13	-11,029.13	100.0%
10	40260	000	00000	000	Litigation Tax - Special Purpose	60,000.00	0.00	60,000.00	6,928.02	62,345.99	-2,345.99	103.9%
10	40266	000	05310	000	Litigation Tax - Jail, Workhouse, or Courthouse - Circuit	0.00	0.00	0.00	1,883.64	6,224.41	-6,224.41	100.0%
10	40268	000	00000	000	Litigation Tax - Courthouse Security	120,000.00	0.00	120,000.00	0.00	0.00	120,000.00	0.000%
10	40268	000	05310	000	Litigation Tax - Courthouse Security - Circuit Court One	0.00	0.00	0.00	0.00	0.00	0.00	100.0%
10	40268	000	05330	000	Litigation Tax - Courthouse Security - General Sessions	0.00	0.00	0.00	13,850.03	126,650.58	-126,650.58	100.0%
10	40268	000	05340	000	Litigation Tax - Courthouse Security - Chancery Court	0.00	0.00	0.00	1,352.12	7,341.35	-7,341.35	100.0%
10	40270	000	00000	000	Business Tax	1,550,000.00	0.00	1,550,000.00	826,020.04	1,444,689.09	105,310.91	93.20%
10	40275	000	00000	000	Mixed Drink Tax	0.00	0.00	0.00	0.00	0.00	0.00	100.0%
10	40350	000	00000	000	Interstate Telecommunications Tax	0.00	0.00	0.00	0.00	0.00	0.00	100.0%
101 40---						23,480,913.	0.00	23,480,913.	1,433,442.97	23,644,714.	-163,801.15	
10	41110	000	00000	000	Marriage Licenses	5,000.00	0.00	5,000.00	361.00	4,436.50	563.50	88.73%

REVENUE SUMMARY REPORT

May 2025-2026

HAMBLLEN COUNTY ACCOUNTS & BUDGETS

101 General Fund

Fund(s) Selected:
101; 122; 128; 151; 154;
171; 173; 176; 177; 178;

Fd	Acct	Obj	Loc	Prg	Description	Budget Amount	Budget Amendments	Amended Budget	MTD Revenues	YTD Revenues	Uncollected Revenues	% of Bdgt
10	41140	000	00000	000	Cable TV Franchise	200,000.00	0.00	200,000.00	37,561.53	204,292.17	-4,292.17	102.1%
10	41520	000	00000	000	Building Permits	150,000.00	0.00	150,000.00	21,559.05	171,871.20	-21,871.20	114.5%
101 41---						355,000.00	0.00	355,000.00	59,481.58	380,599.87	-25,599.87	
10	42110	000	00000	000	Fines	4,000.00	0.00	4,000.00	527.49	6,029.37	-2,029.37	150.7%
10	42120	000	00000	000	Officers Costs	16,000.00	0.00	16,000.00	1,471.06	15,727.16	272.84	98.29%
10	42140	000	00000	000	Drug Control Fines	10,000.00	0.00	10,000.00	244.79	14,828.62	-4,828.62	148.2%
10	42141	000	00000	000	Drug Court Fees	2,000.00	0.00	2,000.00	248.90	2,852.38	-852.38	142.6%
10	42150	000	00000	000	Jail Fees	400.00	0.00	400.00	0.00	31.59	368.41	7.897%
10	42180	000	00000	000	DUI Treatment Fines	1,000.00	0.00	1,000.00	555.75	1,695.75	-695.75	169.5%
10	42190	000	00000	000	Data Entry Fee - Circuit Court	3,500.00	0.00	3,500.00	304.75	4,036.21	-536.21	115.3%
10	42310	000	00000	000	Fines	25,000.00	0.00	25,000.00	2,785.99	25,160.84	-160.84	100.6%
10	42311	000	00000	000	Fines For Littering	0.00	0.00	0.00	0.00	57.00	-57.00	100.0%
10	42320	000	00000	000	Officers Costs	48,000.00	0.00	48,000.00	4,816.64	58,796.91	-10,796.91	122.4%
10	42330	000	00000	000	Game And Fish Fines	100.00	0.00	100.00	9.00	609.75	-509.75	609.7%
10	42340	000	00000	000	Drug Control Fines	0.00	0.00	0.00	0.00	0.00	0.00	100.0%
10	42341	000	00000	000	Drug Court Fees	10,000.00	0.00	10,000.00	932.75	10,397.32	-397.32	103.9%
10	42350	000	00000	000	Jail Fees	30,000.00	0.00	30,000.00	879.59	24,754.96	5,245.04	82.51%
10	42351	000	00000	000	Interpreter Fee	0.00	0.00	0.00	0.00	11.87	-11.87	100.0%
10	42380	000	00000	000	DUI Treatment Fines	7,000.00	0.00	7,000.00	712.50	5,781.46	1,218.54	82.59%
10	42390	000	00000	000	Data Entry Fee - General Sessions Court	20,000.00	0.00	20,000.00	4,010.00	28,020.50	-8,020.50	140.1%
10	42391	000	00000	000	Courtroom Security Fee	500.00	0.00	500.00	100.70	800.17	-300.17	160.0%
10	42410	000	00000	000	Fines	1,000.00	0.00	1,000.00	50.00	610.50	389.50	61.05%
10	42420	000	00000	000	Officers Costs	6,000.00	0.00	6,000.00	836.95	9,694.75	-3,694.75	161.5%
10	42440	000	00000	000	Drug Control Fines	2,000.00	0.00	2,000.00	325.00	2,202.00	-202.00	110.1%
10	42450	000	00000	000	Jail Fees	0.00	0.00	0.00	0.00	0.00	0.00	100.0%
10	42451	000	00000	000	Interpreter Fee	200.00	0.00	200.00	0.00	0.00	200.00	0.000%
10	42490	000	00000	000	Data Entry Fee - Juvenile Court	1,500.00	0.00	1,500.00	169.00	1,250.00	250.00	83.33%

REVENUE SUMMARY REPORT

May 2025-2026

HAMBLEN COUNTY ACCOUNTS & BUDGETS

101 General Fund

Fund(s) Selected:
101; 122; 128; 151; 154;
171; 173; 176; 177; 178;

Fd	Acct	Obj	Loc	Prg Description	Budget Amount	Budget Amendments	Amended Budget	MTD Revenues	YTD Revenues	Uncollected Revenues	% of Bdgt
10	42491	000	00000	000 Courtroom Security Fee	0.00	0.00	0.00	0.00	0.00	0.00	100.0%
10	42520	000	00000	000 Officers Costs	0.00	0.00	0.00	0.00	0.00	0.00	100.0%
10	42530	000	00000	000 Data Entry Fee-Chancery Court	7,000.00	0.00	7,000.00	1,039.00	5,606.00	1,394.00	80.08%
10	42641	000	00000	000 Drug Court Fees	13,000.00	5,500.00	18,500.00	4,460.00	30,760.50	-12,260.50	166.2%
10	42641	000	02008	000 Drug Court Fees - Testing Of Outside Entities	0.00	0.00	0.00	0.00	963.00	-963.00	100.0%
10	42910	000	00000	000 Proceeds From Confiscated Property	0.00	0.00	0.00	0.00	0.00	0.00	100.0%
10	42990	000	00000	000 Other Fines, Forfeitures, And Penalties	100.00	0.00	100.00	9.50	92.12	7.88	92.12%
101 42---					208,300.00	5,500.00	213,800.00	24,489.36	250,770.73	-36,970.73	
10	43102	000	00000	000 Other Employee Benefit Charges/Contributions	0.00	0.00	0.00	0.00	0.00	0.00	100.0%
10	43102	000	01080	000 Other Employee Benefit Charges/Contributions - Solid	0.00	0.00	0.00	0.00	0.00	0.00	100.0%
10	43102	000	01085	000 Other Employee Benefit Charges/Contributions - E-911	0.00	0.00	0.00	0.00	0.00	0.00	100.0%
10	43120	000	00000	000 Patient Charges	16,000.00	0.00	16,000.00	1,479.62	16,040.13	-40.13	100.2%
10	43170	000	00000	000 Work Release Charges For Board	0.00	0.00	0.00	0.00	144.00	-144.00	100.0%
10	43340	000	00000	000 Recreation Fees	140,000.00	0.00	140,000.00	11,008.60	139,830.10	169.90	99.87%
10	43350	000	00000	000 Copy Fees	8,000.00	0.00	8,000.00	0.00	106.42	7,893.58	1.330%
10	43350	000	05160	000 Copy Fees - Register Of Deeds	0.00	0.00	0.00	6.00	427.35	-427.35	100.0%
10	43350	000	05170	000 Copy Fees - Planning And Zoning	0.00	0.00	0.00	0.00	0.00	0.00	100.0%
10	43350	000	05191	000 Copy Fees - Archives	0.00	0.00	0.00	0.00	0.00	0.00	100.0%
10	43350	000	05230	000 Copy Fees - Assessor Of Property/Reapprais	0.00	0.00	0.00	0.00	0.00	0.00	100.0%
10	43350	000	05250	000 Copy Fees - County Clerk	0.00	0.00	0.00	925.36	8,889.94	-8,889.94	100.0%
10	43366	000	00000	000 Greenbelt Late Application Fee	0.00	0.00	0.00	0.00	0.00	0.00	100.0%
10	43370	000	00000	000 Telephone Commissions	31,000.00	0.00	31,000.00	13,327.29	68,499.32	-37,499.32	220.9%
10	43380	000	00000	000 Vending Machine Collections	0.00	0.00	0.00	0.00	9.98	-9.98	100.0%
10	43381	000	00000	000 Tourism Fees	26,700.00	0.00	26,700.00	34,750.00	87,750.00	-61,050.00	328.6%
10	43382	000	00000	000 Electronic Citation Fees - General Sessions	100.00	0.00	100.00	2.00	25.00	75.00	25.00%
10	43383	000	00000	000 Additional Fees - Titling and Registration	75,000.00	0.00	75,000.00	7,950.00	69,516.00	5,484.00	92.68%
10	43390	000	00000	000 Constitutional Officers' Fees & Commissions	0.00	0.00	0.00	0.00	0.00	0.00	100.0%

REVENUE SUMMARY REPORT

May 2025-2026

HAMBLEN COUNTY ACCOUNTS & BUDGETS

101 General Fund

Fund(s) Selected:
101; 122; 128; 151; 154;
171; 173; 176; 177; 178;

Fd	Acct	Obj	Loc	Prg	Description	Budget Amount	Budget Amendments	Amended Budget	MTD Revenues	YTD Revenues	Uncollected Revenues	% of Bdgt
10	43392	000	00000	000	Data Processing Fee - Register	16,000.00	0.00	16,000.00	1,944.00	16,934.00	-934.00	105.8%
10	43393	000	00000	000	Probation Fees	1,000.00	0.00	1,000.00	9.02	529.96	470.04	52.99%
10	43394	000	00000	000	Data Processing Fee - Sheriff	8,000.00	0.00	8,000.00	41.80	520.60	7,479.40	6.507%
10	43394	000	05310	000	Data Processing Fee - Sheriff - Circuit Court One (1)	0.00	0.00	0.00	67.21	546.72	-546.72	100.0%
10	43394	000	05330	000	Data Processing Fee - Sheriff - General Sessions One	0.00	0.00	0.00	557.65	5,809.62	-5,809.62	100.0%
10	43395	000	00000	000	Sexual Offender Registration Fee - Sheriff	3,000.00	0.00	3,000.00	450.00	7,050.00	-4,050.00	235.0%
10	43396	000	00000	000	Data Processing Fees - County Clerk	6,000.00	0.00	6,000.00	1,365.00	4,635.00	1,365.00	77.25%
10	43399	000	00000	000	Vehicle Insurance Coverage and Reinstatement Fees	29,000.00	0.00	29,000.00	2,135.00	19,340.00	9,660.00	66.68%
10	43582	000	00000	000	Community Service Fees - Adults	3,000.00	0.00	3,000.00	85.50	565.72	2,434.28	18.85%
10	43990	000	30001	000	Other Charges For Services - Supervision Fees	0.00	0.00	0.00	19,434.00	210,139.55	-210,139.55	100.0%
10	43990	000	30002	000	Other Charges For Services - IPS/Litter Fees	0.00	0.00	0.00	510.00	4,915.00	-4,915.00	100.0%
10	43990	000	30003	000	Other Charges For Services - Drug Screen Fees	0.00	0.00	0.00	150.00	675.00	-675.00	100.0%
10	43990	000	30004	000	Other Charges For Services - Other Fees Collected	0.00	0.00	0.00	0.00	0.00	0.00	100.0%
10	43990	000	00000	000	Other Charges For Services	200,000.00	0.00	200,000.00	0.00	0.00	200,000.00	0.000%
101 43---						562,800.00	0.00	562,800.00	96,198.05	662,899.41	-100,099.41	
10	44110	000	00000	000	Investment Income	0.00	0.00	0.00	0.00	0.00	0.00	100.0%
10	44120	000	00000	000	Lease/Rentals	53,600.00	0.00	53,600.00	0.00	0.00	53,600.00	0.000%
10	44120	000	06100	000	Lease/Rentals - Pavilion/Shed Rental Fees	0.00	0.00	0.00	4,252.00	32,107.00	-32,107.00	100.0%
10	44120	000	06110	000	Lease/Rentals - Boat Dock Fees	0.00	0.00	0.00	0.00	8,610.33	-8,610.33	100.0%
10	44120	000	06130	000	Lease/Rentals - Archery Club Lease	0.00	0.00	0.00	0.00	1,000.00	-1,000.00	100.0%
10	44120	000	09100	000	Lease/Rentals - State Health Dept (Tdec)	0.00	0.00	0.00	0.00	0.00	0.00	100.0%
10	44120	000	06120	000	Lease/Rentals - Trap Club Lease	0.00	0.00	0.00	0.00	0.00	0.00	100.0%
10	44120	000	06140	000	Lease/Rentals - Amphitheater Fees	0.00	0.00	0.00	0.00	80.00	-80.00	100.0%
10	44120	000	55110	000	Lease/Rentals - Health Department	0.00	0.00	0.00	1,650.00	29,340.04	-29,340.04	100.0%
10	44130	000	00000	000	Sale Of Materials And Supplies	0.00	0.00	0.00	0.00	0.00	0.00	100.0%
10	44131	000	00000	000	Commissary Sales	16,000.00	0.00	16,000.00	1,134.00	15,094.00	906.00	94.33%
10	44140	000	00000	000	Sale Of Maps	0.00	0.00	0.00	0.00	0.00	0.00	100.0%

REVENUE SUMMARY REPORT

May 2025-2026

HAMBLEN COUNTY ACCOUNTS & BUDGETS

101 General Fund

Fund(s) Selected:
101; 122; 128; 151; 154;
171; 173; 176; 177; 178;

Fd	Acct	Obj	Loc	Prg	Description	Budget Amount	Budget Amendments	Amended Budget	MTD Revenues	YTD Revenues	Uncollected Revenues	% of Bdgt
10	44140	000	05230	000	Sale Of Maps - Assessor Of Property/Reapprais	0.00	0.00	0.00	0.00	0.00	0.00	100.0%
10	44160	000	00000	000	Retirees' Insurance Payments	0.00	0.00	0.00	0.00	0.00	0.00	100.0%
10	44165	000	00000	000	Commodity Rebates	0.00	0.00	0.00	77,600.00	77,600.00	-77,600.00	100.0%
10	44170	000	00000	000	Miscellaneous Refunds	50,000.00	25,676.81	75,676.81	3,742.18	128,544.85	-52,868.04	169.8%
10	44170	000	05150	000	Miscellaneous Refunds - Election Commission	0.00	0.00	0.00	70.00	1,050.90	-1,050.90	100.0%
10	44170	000	05250	000	Miscellaneous Refunds - County Clerk	0.00	0.00	0.00	3,872.74	35,730.58	-35,730.58	100.0%
10	44170	000	05414	028	Miscellaneous Refunds - Tax Enforcement	0.00	0.00	0.00	0.00	0.00	0.00	100.0%
10	44180	000	00000	000	Expenditure Credits	0.00	0.00	0.00	4,723.34	-48,068.26	48,068.26	100.0%
10	44530	000	00000	000	Sale Of Equipment	20,000.00	2,875.00	22,875.00	13,116.00	21,692.00	1,183.00	94.82%
10	44540	000	00000	000	Sale Of Property	0.00	0.00	0.00	0.00	0.00	0.00	100.0%
10	44560	000	00000	000	Damages Recovered From Individuals	0.00	0.00	0.00	0.00	14,900.00	-14,900.00	100.0%
10	44570	000	00000	000	Contributions & Gifts	0.00	0.00	0.00	0.00	0.00	0.00	100.0%
10	44990	000	00000	000	Other Local Revenues	2,000.00	0.00	2,000.00	119.00	3,216.52	-1,216.52	160.8%
101 44---						141,600.00	28,551.81	170,151.81	110,279.26	320,897.96	-150,746.15	
10	45180	000	00000	000	Register	0.00	0.00	0.00	0.00	0.00	0.00	100.0%
10	45510	000	00000	000	County Clerk	850,000.00	0.00	850,000.00	110,082.64	777,444.96	72,555.04	91.46%
10	45520	000	00000	000	Circuit Court Clerk	300,000.00	0.00	300,000.00	11,296.17	204,884.07	95,115.93	68.29%
10	45520	000	05310	000	Circuit Court Clerk - Circuit Court One (1)	0.00	0.00	0.00	12,687.92	108,835.77	-108,835.77	100.0%
10	45540	000	00000	000	General Sessions Court Clerk	625,000.00	0.00	625,000.00	46,744.97	418,242.19	206,757.81	66.91%
10	45540	000	05330	000	General Sessions Court Clerk - General Sessions	0.00	0.00	0.00	32,065.07	290,861.75	-290,861.75	100.0%
10	45550	000	00000	000	Clerk And Master	180,000.00	0.00	180,000.00	25,539.12	178,833.78	1,166.22	99.35%
10	45560	000	00000	000	Juvenile Court Clerk	40,000.00	0.00	40,000.00	2,467.49	30,760.45	9,239.55	76.90%
10	45580	000	00000	000	Register	290,000.00	0.00	290,000.00	22,267.35	289,972.57	27.43	99.99%
10	45590	000	00000	000	Sheriff	22,000.00	0.00	22,000.00	5,358.00	25,742.70	-3,742.70	117.0%
10	45610	000	00000	000	Trustee	1,275,000.00	0.00	1,275,000.00	76,094.38	1,401,032.55	-126,032.55	109.8%
101 45---						3,582,000.00	0.00	3,582,000.00	344,603.11	3,726,610.79	-144,610.79	

REVENUE SUMMARY REPORT

May 2025-2026

HAMBLEN COUNTY ACCOUNTS & BUDGETS

101 General Fund

Fund(s) Selected:
101; 122; 128; 151; 154;
171; 173; 176; 177; 178;

Fd	Acct	Obj	Loc	Prg Description	Budget Amount	Budget Amendments	Amended Budget	MTD Revenues	YTD Revenues	Uncollected Revenues	% of Bdgt
10	46110	000	00000	000 Juvenile Services Program	9,000.00	0.00	9,000.00	0.00	4,500.00	4,500.00	50.00%
10	46170	000	00000	000 Solid Waste Grants	95,000.00	0.00	95,000.00	17,773.71	78,586.26	16,413.74	82.72%
10	46190	000	00000	000 Other General Government Grants	0.00	0.00	0.00	0.00	0.00	0.00	100.0%
10	46210	000	00000	000 Law Enforcement Training Programs	47,900.00	0.00	47,900.00	0.00	0.00	47,900.00	0.000%
10	46240	000	00000	000 School Resources Officer Grants	1,350,000.00	0.00	1,350,000.00	0.00	1,350,000.00	0.00	100.0%
10	46290	000	00000	000 Other Public Safety Grants	0.00	64,500.00	64,500.00	0.00	275,800.00	-211,300.00	427.5%
10	46300	000	00000	000 Health And Welfare Grants	0.00	0.00	0.00	0.00	0.00	0.00	100.0%
10	46310	000	00000	000 Health Department Programs	1,400,988.00	0.00	1,400,988.00	61,957.91	549,982.34	851,005.66	39.25%
10	46430	000	00000	000 Litter Program	47,700.00	0.00	47,700.00	0.00	41,906.62	5,793.38	87.85%
10	46820	000	00000	000 Income Tax	0.00	0.00	0.00	0.00	0.00	0.00	100.0%
10	46835	000	00000	000 Vehicle Certificate Of Title Fees	15,000.00	0.00	15,000.00	1,258.90	11,801.15	3,198.85	78.67%
10	46840	000	00000	000 Alcoholic Beverage Tax	115,000.00	0.00	115,000.00	24,789.21	114,867.27	132.73	99.88%
10	46851	000	00000	000 State Revenue Sharing - T.V.A.	810,000.00	0.00	810,000.00	0.00	648,217.28	161,782.72	80.02%
10	46852	000	00000	000 State Revenue - Telecommunications	53,000.00	0.00	53,000.00	4,149.52	44,529.91	8,470.09	84.01%
10	46855	000	00000	000 State Shared Sports Gaming Privilege Tax	65,000.00	0.00	65,000.00	22,063.09	83,311.60	-18,311.60	128.1%
10	46915	000	00000	000 Contracted Prisoner Boarding	800,000.00	0.00	800,000.00	77,982.00	1,150,829.00	-350,829.00	143.8%
10	46925	000	00000	000 Hybrid/Electric Vehicle Registration Fee	0.00	0.00	0.00	0.00	0.00	0.00	100.0%
10	46960	000	00000	000 Registrar's Salary Supplement	15,164.00	0.00	15,164.00	0.00	11,373.00	3,791.00	75.00%
10	46980	000	00000	000 Other State Grants	666,437.00	57,320.90	723,757.90	1,545,051.74	1,939,549.34	-1,215,791.44	267.9%
10	46980	000	70012	000 Other State Grants - TCI Training Grant	0.00	0.00	0.00	0.00	8,973.62	-8,973.62	100.0%
10	46990	000	00000	000 Other State Revenues	60,000.00	0.00	60,000.00	1,750.00	42,236.42	17,763.58	70.39%
101 46---					5,550,189.00	121,820.90	5,672,009.90	1,756,776.08	6,356,463.81	-684,453.91	
10	47220	000	00000	000 Civil Defense Reimbursement	30,704.00	0.00	30,704.00	454.00	454.00	30,250.00	1.478%
10	47235	000	00000	000 Homeland Security Grants	24,000.00	0.00	24,000.00	0.00	21,400.82	2,599.18	89.17%
10	47301	000	00000	000 COVID-19 Grant #1 Election Funds	0.00	0.00	0.00	0.00	0.00	0.00	100.0%
10	47302	000	00000	000 COVID - Employer Rebate	0.00	0.00	0.00	0.00	0.00	0.00	100.0%
10	47303	000	00000	000 COVID-19 Grant #3 Cares Act	0.00	0.00	0.00	0.00	0.00	0.00	100.0%

REVENUE SUMMARY REPORT

May 2025-2026

HAMBLEN COUNTY ACCOUNTS & BUDGETS

101 General Fund

Fund(s) Selected:
101; 122; 128; 151; 154;
171; 173; 176; 177; 178;

Fd	Acct	Obj	Loc	Prg	Description	Budget Amount	Budget Amendments	Amended Budget	MTD Revenues	YTD Revenues	Uncollected Revenues	% of Bdgt
10	47304	000	00000	000	COVID-19 Grant #3	0.00	0.00	0.00	0.00	0.00	0.00	100.0%
10	47305	000	00000	000	COVID-19 Grant #4	0.00	0.00	0.00	0.00	0.00	0.00	100.0%
10	47590	000	00000	000	Other Federal Through State	5,000.00	0.00	5,000.00	0.00	156,478.28	-151,478.28	3129.9%
10	47590	000	06500	000	Other Federal Through State - Oak Tree Plaza	0.00	0.00	0.00	0.00	0.00	0.00	100.0%
10	47590	000	70013	000	Other Federal Through State - BRC - Boys & Girls Club	0.00	0.00	0.00	0.00	0.00	0.00	100.0%
10	47590	000	70014	000	Other Federal Through State - BRC - Girls Inc.	0.00	0.00	0.00	0.00	0.00	0.00	100.0%
10	47590	000	70015	000	Other Federal Through State - BRC - HOLA	0.00	0.00	0.00	0.00	8,222.74	-8,222.74	100.0%
10	47590	000	70016	000	Other Federal Through State - BRC - Library	0.00	0.00	0.00	0.00	2,116.60	-2,116.60	100.0%
10	47590	000	70017	000	Other Federal Through State - BRC - Senior Citizen	0.00	0.00	0.00	0.00	0.00	0.00	100.0%
10	47590	000	70018	000	Other Federal Through State - BRC - Stepping Out	0.00	0.00	0.00	0.00	0.00	0.00	100.0%
10	47590	000	70019	000	Other Federal Through State - BRC - Maint. Block	0.00	0.00	0.00	0.00	0.00	0.00	100.0%
10	47590	000	70021	000	Other Federal Through State - BRC - Capital Expenses	0.00	0.00	0.00	0.00	0.00	0.00	100.0%
10	47590	000	70022	000	Other Federal Through State - BRC - Admin	0.00	0.00	0.00	0.00	2,000.00	-2,000.00	100.0%
10	47590	000	70020	000	Other Federal Through State - BRC - Professional Fees	0.00	0.00	0.00	0.00	4,000.00	-4,000.00	100.0%
10	47990	000	00000	000	Other Direct Federal Revenue	24,000.00	0.00	24,000.00	0.00	5,709.12	18,290.88	23.78%
10	47990	000	04030	000	Other Direct Federal Revenue - Social Security	0.00	0.00	0.00	0.00	400.00	-400.00	100.0%
10	47990	000	80001	000	Other Direct Federal Revenue - SAMHSA Direct	0.00	0.00	0.00	0.00	156,608.07	-156,608.07	100.0%
10	47990	000	81001	000	Other Direct Federal Revenue - SAMHSA Indirect	0.00	0.00	0.00	0.00	33,733.00	-33,733.00	100.0%
101 47---						83,704.00	0.00	83,704.00	454.00	391,122.63	-307,418.63	
10	48130	000	00000	000	Contributions	0.00	0.00	0.00	344.17	344.17	-344.17	100.0%
10	48140	000	00000	000	Contracted Services	320,000.00	0.00	320,000.00	89,059.94	306,421.38	13,578.62	95.75%
10	48610	000	00000	000	Donations	1,000.00	0.00	1,000.00	0.00	400.00	600.00	40.00%
10	48610	000	05191	000	Donations - Archives	0.00	0.00	0.00	0.00	213.26	-213.26	100.0%
10	48990	000	00000	000	Other	0.00	0.00	0.00	0.00	0.00	0.00	100.0%
101 48---						321,000.00	0.00	321,000.00	89,404.11	307,378.81	13,621.19	
10	49700	000	00000	000	Insurance Recovery	0.00	2,296.69	2,296.69	678.20	19,801.09	-17,504.40	862.1%

REVENUE SUMMARY REPORT

May 2025-2026

HAMBLEEN COUNTY ACCOUNTS & BUDGETS

101 General Fund

Fund(s) Selected:
101; 122; 128; 151; 154;
171; 173; 176; 177; 178;

Fd	Acct	Obj	Loc	Prg	Description	Budget Amount	Budget Amendments	Amended Budget	MTD Revenues	YTD Revenues	Uncollected Revenues	% of Bdgt
10	49800	000	00000	000	Transfers In	150,000.00	10,000.00	160,000.00	0.00	10,000.00	150,000.00	6.250%
					101 49---	<u>150,000.00</u>	<u>12,296.69</u>	<u>162,296.69</u>	<u>678.20</u>	<u>29,801.09</u>	<u>132,495.60</u>	
					General Fund #(101) Totals:	<u>34,435,506.</u>	<u>168,169.40</u>	<u>34,603,675.</u>	<u>3,915,806.72</u>	<u>36,071,259.</u>	<u>-1,467,583.85</u>	

REVENUE SUMMARY REPORT

May 2025-2026

HAMBLLEN COUNTY ACCOUNTS & BUDGETS

101 General Fund

Fund(s) Selected:
101; 122; 128; 151; 154;
171; 173; 176; 177; 178;

Fd	Acct	Obj	Loc	Prg	Description	Budget Amount	Budget Amendments	Amended Budget	MTD Revenues	YTD Revenues	Uncollected Revenues	% of Bdgt
12	42140	000	00000	000	Drug Control Fines	1,800.00	0.00	1,800.00	14.25	196.64	1,603.36	10.92%
12	42240	000	00000	000	Drug Control Fines	0.00	0.00	0.00	0.00	0.00	0.00	100.0%
12	42340	000	00000	000	Drug Control Fines	7,500.00	0.00	7,500.00	409.21	8,814.88	-1,314.88	117.5%
12	42910	000	00000	000	Proceeds From Confiscated Property	10,000.00	0.00	10,000.00	10,274.50	25,631.50	-15,631.50	256.3%
12	42990	000	00000	000	Other Fines, Forfeitures, And Penalties	0.00	0.00	0.00	0.00	0.00	0.00	100.0%
					122 42---	19,300.00	0.00	19,300.00	10,697.96	34,643.02	-15,343.02	
12	44110	000	00000	000	Investment Income	10,000.00	0.00	10,000.00	1,066.63	12,482.82	-2,482.82	124.8%
12	44170	000	00000	000	Miscellaneous Refunds	0.00	0.00	0.00	0.00	0.00	0.00	100.0%
12	44530	000	00000	000	Sale Of Equipment	0.00	0.00	0.00	0.00	0.00	0.00	100.0%
12	44560	000	00000	000	Damages Recovered From Individuals	0.00	0.00	0.00	1,396.50	2,842.00	-2,842.00	100.0%
					122 44---	10,000.00	0.00	10,000.00	2,463.13	15,324.82	-5,324.82	
12	46980	000	00000	000	Other State Grants	0.00	0.00	0.00	0.00	0.00	0.00	100.0%
					122 46---	0.00	0.00	0.00	0.00	0.00	0.00	
12	47590	000	00000	000	Other Federal Through State	0.00	0.00	0.00	0.00	0.00	0.00	100.0%
12	47700	000	00000	000	Asset Forfeiture Funds	0.00	0.00	0.00	0.00	0.00	0.00	100.0%
					122 47---	0.00	0.00	0.00	0.00	0.00	0.00	
12	48130	000	00000	000	Contributions	0.00	0.00	0.00	0.00	0.00	0.00	100.0%
12	48610	000	00000	000	Donations	0.00	0.00	0.00	0.00	0.00	0.00	100.0%
12	48990	000	00000	000	Other	0.00	0.00	0.00	0.00	0.00	0.00	100.0%
					122 48---	0.00	0.00	0.00	0.00	0.00	0.00	
12	49700	000	00000	000	Insurance Recovery	0.00	0.00	0.00	0.00	0.00	0.00	100.0%

REVENUE SUMMARY REPORT

May 2025-2026

HAMBLEEN COUNTY ACCOUNTS & BUDGETS

101 General Fund

Fund(s) Selected:
101; 122; 128; 151; 154;
171; 173; 176; 177; 178;

Fd	Acct	Obj	Loc	Prg Description	Budget Amount	Budget Amendments	Amended Budget	MTD Revenues	YTD Revenues	Uncollected Revenues	% of Bdgt
				122 49---	0.00	0.00	0.00	0.00	0.00	0.00	
Drug Control Fund #(122) Totals:					29,300.00	0.00	29,300.00	13,161.09	49,967.84	-20,667.84	

REVENUE SUMMARY REPORT

May 2025-2026

HAMBLEN COUNTY ACCOUNTS & BUDGETS

101 General Fund

Fund(s) Selected:
101; 122; 128; 151; 154;
171; 173; 176; 177; 178;

Fd	Acct	Obj	Loc	Prg Description	Budget Amount	Budget Amendments	Amended Budget	MTD Revenues	YTD Revenues	Uncollected Revenues	% of Bdgt
12	44110	000	00000	000 Investment Income	0.00	0.00	0.00	6,016.10	76,537.83	-76,537.83	100.0%
12	44170	000	00000	000 Miscellaneous Refunds	0.00	0.00	0.00	0.00	0.00	0.00	100.0%
			128 44---		0.00	0.00	0.00	6,016.10	76,537.83	-76,537.83	
12	46845	000	00000	000 Opioid Settlement Funds	0.00	0.00	0.00	0.00	176,766.32	-176,766.32	100.0%
			128 46---		0.00	0.00	0.00	0.00	176,766.32	-176,766.32	
12	48990	000	00000	000 Other	0.00	0.00	0.00	0.00	0.00	0.00	100.0%
12	48991	000	00000	000 Opioid Subdivision Funds	0.00	0.00	0.00	0.00	234,346.68	-234,346.68	100.0%
			128 48---		0.00	0.00	0.00	0.00	234,346.68	-234,346.68	
12	49800	000	00000	000 Transfers In	0.00	0.00	0.00	0.00	0.00	0.00	100.0%
			128 49---		0.00	0.00	0.00	0.00	0.00	0.00	
Drug Use Abatement Fund Totals:					0.00	0.00	0.00	6,016.10	487,650.83	-487,650.83	

REVENUE SUMMARY REPORT

May 2025-2026

HAMBLLEN COUNTY ACCOUNTS & BUDGETS

101 General Fund

Fund(s) Selected:
101; 122; 128; 151; 154;
171; 173; 176; 177; 178;

Fd	Acct	Obj	Loc	Prg	Description	Budget Amount	Budget Amendments	Amended Budget	MTD Revenues	YTD Revenues	Uncollected Revenues	% of Bdgt
15	40110	000	00000	000	Current Property Tax	7,100,000.00	0.00	7,100,000.00	167,527.64	7,001,347.18	98,652.82	98.61%
15	40120	000	00000	000	Trustee's Collections - Prior Year	133,000.00	0.00	133,000.00	5,302.99	180,653.19	-47,653.19	135.8%
15	40125	000	00000	000	Trustee Collections - Bankruptcy	1,500.00	0.00	1,500.00	57.12	1,202.78	297.22	80.18%
15	40130	000	00000	000	Circuit Clerk/Clerk & Master Collections-Prior Yrs	39,000.00	0.00	39,000.00	5,772.17	26,530.97	12,469.03	68.02%
15	40140	000	00000	000	Interest And Penalty	43,000.00	0.00	43,000.00	8,126.46	49,006.00	-6,006.00	113.9%
15	40161	000	00000	000	Payments In Lieu Of Taxes - T.V.A.	624.00	0.00	624.00	0.00	0.00	624.00	0.000%
15	40162	000	00000	000	Payments In Lieu Of Taxes - Local Utilities	105,000.00	0.00	105,000.00	7,149.82	81,387.67	23,612.33	77.51%
15	40163	000	00000	000	Payments In Lieu Of Taxes - Other	30,000.00	0.00	30,000.00	0.00	21,605.81	8,394.19	72.01%
15	40210	000	00000	000	Local Option Sales Tax	0.00	0.00	0.00	0.00	0.00	0.00	100.0%
15	40266	000	00000	000	Litigation Tax - Jail, Workhouse, or Courthouse	100,000.00	0.00	100,000.00	18,554.22	144,194.94	-44,194.94	144.1%
15	40320	000	00000	000	Bank Excise Tax	35,000.00	0.00	35,000.00	0.00	38,320.40	-3,320.40	109.4%
					151 40---	7,587,124.00	0.00	7,587,124.00	212,490.42	7,544,248.94	42,875.06	
15	42150	000	00000	000	Jail Fees	2,000.00	0.00	2,000.00	209.88	1,838.51	161.49	91.92%
15	42350	000	00000	000	Jail Fees	65,000.00	0.00	65,000.00	8,585.04	79,413.24	-14,413.24	122.1%
					151 42---	67,000.00	0.00	67,000.00	8,794.92	81,251.75	-14,251.75	
15	44110	000	00000	000	Investment Income	1,800,000.00	0.00	1,800,000.00	260,748.44	1,627,383.03	172,616.97	90.41%
15	44170	000	00000	000	Miscellaneous Refunds	0.00	0.00	0.00	0.00	2,263.74	-2,263.74	100.0%
15	44990	000	00000	000	Other Local Revenues	500,000.00	0.00	500,000.00	0.00	500,000.00	0.00	100.0%
					151 44---	2,300,000.00	0.00	2,300,000.00	260,748.44	2,129,646.77	170,353.23	
15	48990	000	00000	000	Other	0.00	0.00	0.00	0.00	0.00	0.00	100.0%
					151 48---	0.00	0.00	0.00	0.00	0.00	0.00	
15	49800	000	00000	000	Transfers In	0.00	0.00	0.00	0.00	0.00	0.00	100.0%

REVENUE SUMMARY REPORT

May 2025-2026

HAMBLEEN COUNTY ACCOUNTS & BUDGETS

101 General Fund

Fund(s) Selected:
101; 122; 128; 151; 154;
171; 173; 176; 177; 178;

Fd	Acct	Obj	Loc	Prg Description	Budget Amount	Budget Amendments	Amended Budget	MTD Revenues	YTD Revenues	Uncollected Revenues	% of Bdgt
		151	49---		0.00	0.00	0.00	0.00	0.00	0.00	
General Debt Service Fund #(151) Totals:					9,954,124.00	0.00	9,954,124.00	482,033.78	9,755,147.46	198,976.54	

REVENUE SUMMARY REPORT

May 2025-2026

HAMBLLEN COUNTY ACCOUNTS & BUDGETS

101 General Fund

Fund(s) Selected:
101; 122; 128; 151; 154;
171; 173; 176; 177; 178;

Fd	Acct	Obj	Loc	Prg Description	Budget Amount	Budget Amendments	Amended Budget	MTD Revenues	YTD Revenues	Uncollected Revenues	% of Bdgt
15	44110	000	00000	000 Investment Income	200,000.00	0.00	200,000.00	9,841.10	128,900.49	71,099.51	64.45%
				154 44---	200,000.00	0.00	200,000.00	9,841.10	128,900.49	71,099.51	
15	48990	000	00000	000 Other	879,749.00	0.00	879,749.00	0.00	406,301.85	473,447.15	46.18%
				154 48---	879,749.00	0.00	879,749.00	0.00	406,301.85	473,447.15	
15	49100	000	00000	000 Bonds Issued	0.00	0.00	0.00	0.00	0.00	0.00	100.0%
15	49410	000	00000	000 Premiums On Debt Sold	0.00	0.00	0.00	0.00	0.00	0.00	100.0%
15	49800	000	00000	000 Transfers In	0.00	0.00	0.00	0.00	0.00	0.00	100.0%
				154 49---	0.00	0.00	0.00	0.00	0.00	0.00	
Special Debt Service Totals:					1,079,749.00	0.00	1,079,749.00	9,841.10	535,202.34	544,546.66	

REVENUE SUMMARY REPORT

May 2025-2026

HAMBLEN COUNTY ACCOUNTS & BUDGETS

101 General Fund

Fund(s) Selected:
101; 122; 128; 151; 154;
171; 173; 176; 177; 178;

Fd	Acct	Obj	Loc	Prg	Description	Budget Amount	Budget Amendments	Amended Budget	MTD Revenues	YTD Revenues	Uncollected Revenues	% of Bdgt
17	44110	000	00000	000	Investment Income	0.00	0.00	0.00	0.00	0.00	0.00	100.0%
17	44120	000	00000	000	Lease/Rentals	0.00	0.00	0.00	0.00	0.00	0.00	100.0%
17	44170	000	00000	000	Miscellaneous Refunds	0.00	0.00	0.00	0.00	0.00	0.00	100.0%
17	44530	000	00000	000	Sale Of Equipment	0.00	0.00	0.00	0.00	0.00	0.00	100.0%
171 44---						0.00	0.00	0.00	0.00	0.00	0.00	
17	46190	000	00000	000	Other General Government Grants	0.00	0.00	0.00	0.00	0.00	0.00	100.0%
17	46980	000	00000	000	Other State Grants	0.00	0.00	0.00	0.00	0.00	0.00	100.0%
17	46980	000	07004	000	Other State Grants - CDBG Grant - Fire Engine	0.00	0.00	0.00	0.00	0.00	0.00	100.0%
171 46---						0.00	0.00	0.00	0.00	0.00	0.00	
17	47180	000	00000	000	Community Development	0.00	0.00	0.00	0.00	0.00	0.00	100.0%
17	47590	000	00000	000	Other Federal Through State	0.00	0.00	0.00	0.00	421,597.33	-421,597.33	100.0%
17	47590	000	07004	000	Other Federal Through State - CDBG Grant - Fire Engine	0.00	0.00	0.00	0.00	0.00	0.00	100.0%
171 47---						0.00	0.00	0.00	0.00	421,597.33	-421,597.33	
17	48610	000	00000	000	Donations	0.00	0.00	0.00	0.00	0.00	0.00	100.0%
171 48---						0.00	0.00	0.00	0.00	0.00	0.00	
17	49100	000	00000	000	Bonds Issued	0.00	0.00	0.00	0.00	0.00	0.00	100.0%
17	49700	000	00000	000	Insurance Recovery	0.00	0.00	0.00	0.00	0.00	0.00	100.0%
17	49800	000	00000	000	Transfers In	0.00	0.00	0.00	0.00	0.00	0.00	100.0%
171 49---						0.00	0.00	0.00	0.00	0.00	0.00	
General Capital Projects Fund #(171) Totals:						0.00	0.00	0.00	0.00	421,597.33	-421,597.33	

REVENUE SUMMARY REPORT

May 2025-2026

HAMBLLEN COUNTY ACCOUNTS & BUDGETS

101 General Fund

Fund(s) Selected:
101; 122; 128; 151; 154;
171; 173; 176; 177; 178;

Fd	Acct	Obj	Loc	Prg	Description	Budget Amount	Budget Amendments	Amended Budget	MTD Revenues	YTD Revenues	Uncollected Revenues	% of Bdgt
17	49800	000	00000	000	Transfers In	0.00	0.00	0.00	0.00	0.00	0.00	100.0%
17	49999	000	00000	000	Prior Year Revenue	0.00	0.00	0.00	0.00	0.00	0.00	100.0%
			173	49---		0.00	0.00	0.00	0.00	0.00	0.00	
					Sanitation Projects Fund #(173) Totals:	0.00	0.00	0.00	0.00	0.00	0.00	

REVENUE SUMMARY REPORT

May 2025-2026

HAMBLÉN COUNTY ACCOUNTS & BUDGETS

101 General Fund

Fund(s) Selected:
101; 122; 128; 151; 154;
171; 173; 176; 177; 178;

Fd	Acct	Obj	Loc	Prg	Description	Budget Amount	Budget Amendments	Amended Budget	MTD Revenues	YTD Revenues	Uncollected Revenues	% of Bdgt
17	40210	000	00000	000	Local Option Sales Tax	0.00	0.00	0.00	0.00	0.00	0.00	100.0%
17	40240	000	00000	000	Wheel Tax	3,030,000.00	0.00	3,030,000.00	297,060.86	2,782,494.50	247,505.50	91.83%
					176 40---	3,030,000.00	0.00	3,030,000.00	297,060.86	2,782,494.50	247,505.50	
17	44110	000	00000	000	Investment Income	365,000.00	0.00	365,000.00	0.00	365,000.00	0.00	100.0%
17	44170	000	00000	000	Miscellaneous Refunds	0.00	0.00	0.00	0.00	0.00	0.00	100.0%
					176 44---	365,000.00	0.00	365,000.00	0.00	365,000.00	0.00	
17	46420	000	00000	000	State Aid Program	0.00	770,839.34	770,839.34	0.00	0.00	770,839.34	0.000%
17	46851	000	00000	000	State Revenue Sharing - T.V.A.	0.00	0.00	0.00	0.00	0.00	0.00	100.0%
17	46980	000	00000	000	Other State Grants	0.00	0.00	0.00	0.00	0.00	0.00	100.0%
					176 46---	0.00	770,839.34	770,839.34	0.00	0.00	770,839.34	
17	47590	000	00000	000	Other Federal Through State	0.00	0.00	0.00	0.00	0.00	0.00	100.0%
					176 47---	0.00	0.00	0.00	0.00	0.00	0.00	
Highway Capital Projects Fund #(176) Totals:						3,395,000.00	770,839.34	4,165,839.34	297,060.86	3,147,494.50	1,018,344.84	

REVENUE SUMMARY REPORT

May 2025-2026

HAMBLEEN COUNTY ACCOUNTS & BUDGETS

101 General Fund

Fund(s) Selected:

101; 122; 128; 151; 154;
171; 173; 176; 177; 178;

Fd	Acct	Obj	Loc	Prg Description	Budget Amount	Budget Amendments	Amended Budget	MTD Revenues	YTD Revenues	Uncollected Revenues	% of Bdgt
17	49100	000	000000	000 Bonds Issued	0.00	0.00	0.00	0.00	0.00	0.00	100.0%
17	49410	000	000000	000 Premiums On Debt Sold	0.00	0.00	0.00	0.00	0.00	0.00	100.0%
			177	49---	0.00	0.00	0.00	0.00	0.00	0.00	
Education Capital Projects Fund #(177) Totals:					0.00	0.00	0.00	0.00	0.00	0.00	

REVENUE SUMMARY REPORT

May 2025-2026

HAMBLLEN COUNTY ACCOUNTS & BUDGETS

101 General Fund

Fund(s) Selected:
101; 122; 128; 151; 154;
171; 173; 176; 177; 178;

Fd	Acct	Obj	Loc	Prg Description	Budget Amount	Budget Amendments	Amended Budget	MTD Revenues	YTD Revenues	Uncollected Revenues	% of Bdgt
17	44110	000	00000	000 Investment Income	0.00	0.00	0.00	7,564.24	82,004.58	-82,004.58	100.0%
			178 44---		0.00	0.00	0.00	7,564.24	82,004.58	-82,004.58	
17	47590	000	00000	000 Other Federal Through State	0.00	0.00	0.00	0.00	1,987,870.09	-1,987,870.09	100.0%
17	47990	000	00000	000 Other Direct Federal Revenue	0.00	0.00	0.00	0.00	0.00	0.00	100.0%
			178 47---		0.00	0.00	0.00	0.00	1,987,870.09	-1,987,870.09	
17	49800	000	00000	000 Transfers In	0.00	0.00	0.00	0.00	0.00	0.00	100.0%
			178 49---		0.00	0.00	0.00	0.00	0.00	0.00	
Other Capital Projects Fund/Fu Totals:					0.00	0.00	0.00	7,564.24	2,069,874.67	-2,069,874.67	

REVENUE SUMMARY REPORT

May 2025-2026

HAMBLEN COUNTY ACCOUNTS & BUDGETS

101 General Fund

Fund(s) Selected:
101; 122; 128; 151; 154;
171; 173; 176; 177; 178;

Fd	Acct	Obj	Loc	Prg Description	Budget Amount	Budget Amendments	Amended Budget	MTD Revenues	YTD Revenues	Uncollected Revenues	% of Bdgt
18	44110	000	00000	000 Investment Income	0.00	0.00	0.00	29,651.62	402,994.93	-402,994.93	100.0%
18	44120	000	00000	000 Lease/Rentals	0.00	0.00	0.00	0.00	0.00	0.00	100.0%
18	44170	000	00000	000 Miscellaneous Refunds	0.00	0.00	0.00	0.00	0.00	0.00	100.0%
			189	44---	0.00	0.00	0.00	29,651.62	402,994.93	-402,994.93	
18	49100	000	00000	000 Bonds Issued	0.00	0.00	0.00	0.00	9,818,146.19	-9,818,146.19	100.0%
18	49410	000	00000	000 Premiums On Debt Sold	0.00	0.00	0.00	0.00	0.00	0.00	100.0%
18	49500	000	00000	000 Other Loans Issued	0.00	0.00	0.00	0.00	0.00	0.00	100.0%
18	49800	000	00000	000 Transfers In	0.00	0.00	0.00	0.00	0.00	0.00	100.0%
			189	49---	0.00	0.00	0.00	0.00	9,818,146.19	-9,818,146.19	
Other Capital Projects Fund # (189) Totals:					0.00	0.00	0.00	29,651.62	10,221,141.	-10,221,141.	

REVENUE SUMMARY REPORT

May 2025-2026

HAMBLEN COUNTY ACCOUNTS & BUDGETS

101 General Fund

Fund(s) Selected:
101; 122; 128; 151; 154;
171; 173; 176; 177; 178;

Fd	Acct	Obj	Loc	Prg	Description	Budget Amount	Budget Amendments	Amended Budget	MTD Revenues	YTD Revenues	Uncollected Revenues	% of Bdgt
26	43101	000	00000	000	Self-Insurance Premiums/Contributions	0.00	0.00	0.00	0.00	0.00	0.00	100.0%
26	43101	000	01002	000	Self-Insurance Premiums/Contributions - Highway	0.00	0.00	0.00	28,889.64	291,359.84	-291,359.84	100.0%
26	43101	000	01003	000	Self-Insurance Premiums/Contributions - Garbage	0.00	0.00	0.00	24,507.80	260,774.75	-260,774.75	100.0%
26	43101	000	01001	000	Self-Insurance Premiums/Contributions - Courthouse	0.00	0.00	0.00	345,833.16	3,336,289.16	-3,336,289.16	100.0%
26	43101	000	01004	000	Self-Insurance Premiums/Contributions - Library	0.00	0.00	0.00	0.00	0.00	0.00	100.0%
26	43101	000	01009	000	Self-Insurance Premiums/Contributions - E911	0.00	0.00	0.00	0.00	0.00	0.00	100.0%
26	43101	000	01010	000	Self-Insurance Premiums/Contributions - Landfill	0.00	0.00	0.00	12,415.06	128,843.09	-128,843.09	100.0%
26	43102	000	01001	001	Other Employee Benefit Charges/Contributions -	0.00	0.00	0.00	11,748.42	111,505.81	-111,505.81	100.0%
26	43102	000	01001	002	Other Employee Benefit Charges/Contributions -	0.00	0.00	0.00	2,624.28	25,364.14	-25,364.14	100.0%
26	43102	000	01002	001	Other Employee Benefit Charges/Contributions - Highway	0.00	0.00	0.00	1,207.16	10,594.78	-10,594.78	100.0%
26	43102	000	01002	002	Other Employee Benefit Charges/Contributions - Highway	0.00	0.00	0.00	203.38	2,105.02	-2,105.02	100.0%
26	43102	000	01003	001	Other Employee Benefit Charges/Contributions - Garbage	0.00	0.00	0.00	890.96	9,468.90	-9,468.90	100.0%
26	43102	000	01003	002	Other Employee Benefit Charges/Contributions - Garbage	0.00	0.00	0.00	160.60	1,765.80	-1,765.80	100.0%
26	43102	000	01004	001	Other Employee Benefit Charges/Contributions - Library	0.00	0.00	0.00	0.00	0.00	0.00	100.0%
26	43102	000	01004	002	Other Employee Benefit Charges/Contributions - Library	0.00	0.00	0.00	0.00	0.00	0.00	100.0%
26	43120	000	00000	000	Patient Charges	0.00	0.00	0.00	0.00	0.00	0.00	100.0%
26	43120	000	01007	000	Patient Charges - Retirees	0.00	0.00	0.00	0.00	0.00	0.00	100.0%
26	43120	000	01099	000	Patient Charges - Cobra	0.00	0.00	0.00	0.00	0.00	0.00	100.0%
26	43120	000	01001	000	Patient Charges - Courthouse	0.00	0.00	0.00	393.71	6,386.99	-6,386.99	100.0%
26	43120	000	01002	000	Patient Charges - Highway	0.00	0.00	0.00	0.00	0.00	0.00	100.0%
26	43120	000	01009	000	Patient Charges - E911	0.00	0.00	0.00	0.00	0.00	0.00	100.0%
26	43120	000	01003	000	Patient Charges - Garbage	0.00	0.00	0.00	0.00	0.00	0.00	100.0%
26	43190	000	01004	000	Other General Service Charges - Library	0.00	0.00	0.00	0.00	5,205.20	-5,205.20	100.0%
26	43190	000	01009	000	Other General Service Charges - E911	0.00	0.00	0.00	0.00	0.00	0.00	100.0%
26	43190	000	01011	000	Other General Service Charges - City Of Morristown	0.00	0.00	0.00	0.00	13,718.57	-13,718.57	100.0%
26	43190	000	01001	000	Other General Service Charges - Courthouse	0.00	0.00	0.00	0.00	0.00	0.00	100.0%
26	43190	000	01010	000	Other General Service Charges - Landfill	0.00	0.00	0.00	0.00	8,346.94	-8,346.94	100.0%
26	43190	000	01002	000	Other General Service Charges - Highway	0.00	0.00	0.00	0.00	0.00	0.00	100.0%

REVENUE SUMMARY REPORT

May 2025-2026

HAMBLLEN COUNTY ACCOUNTS & BUDGETS

101 General Fund

Fund(s) Selected:
101; 122; 128; 151; 154;
171; 173; 176; 177; 178;

Fd	Acct	Obj	Loc	Prg	Description	Budget Amount	Budget Amendments	Amended Budget	MTD Revenues	YTD Revenues	Uncollected Revenues	% of Bdgt
26	43190	000	01003	000	Other General Service Charges - Garbage	0.00	0.00	0.00	0.00	0.00	0.00	100.0%
26	43194	000	01001	000	Service Charges (No Show Fee) - Courthouse	0.00	0.00	0.00	25.00	225.00	-225.00	100.0%
26	43194	000	01010	000	Service Charges (No Show Fee) - Landfill	0.00	0.00	0.00	0.00	0.00	0.00	100.0%
26	43194	000	01002	000	Service Charges (No Show Fee) - Highway	0.00	0.00	0.00	0.00	0.00	0.00	100.0%
26	43194	000	01003	000	Service Charges (No Show Fee) - Garbage	0.00	0.00	0.00	0.00	0.00	0.00	100.0%
26	43194	000	01009	000	Service Charges (No Show Fee) - E911	0.00	0.00	0.00	0.00	0.00	0.00	100.0%
26	43990	000	01001	000	Other Charges For Services - Courthouse	0.00	0.00	0.00	0.00	0.00	0.00	100.0%
26	43990	000	01004	000	Other Charges For Services - Library	0.00	0.00	0.00	0.00	0.00	0.00	100.0%
26	43990	000	01009	000	Other Charges For Services - E911	0.00	0.00	0.00	0.00	0.00	0.00	100.0%
26	43990	000	01010	000	Other Charges For Services - Landfill	0.00	0.00	0.00	0.00	0.00	0.00	100.0%
26	43990	000	01003	000	Other Charges For Services - Garbage	0.00	0.00	0.00	0.00	0.00	0.00	100.0%
26	43990	000	01002	000	Other Charges For Services - Highway	0.00	0.00	0.00	0.00	0.00	0.00	100.0%
264 43---						0.00	0.00	0.00	428,899.17	4,211,953.99	-4,211,953.99	
26	44110	000	00000	000	Investment Income	0.00	0.00	0.00	0.00	0.00	0.00	100.0%
26	44160	000	01007	000	Retirees' Insurance Payments - Retirees	0.00	0.00	0.00	1,500.00	23,250.00	-23,250.00	100.0%
26	44160	000	01007	001	Retirees' Insurance Payments - Retirees	0.00	0.00	0.00	48.08	745.24	-745.24	100.0%
26	44160	000	01007	002	Retirees' Insurance Payments - Retirees	0.00	0.00	0.00	12.80	147.20	-147.20	100.0%
26	44161	000	00000	000	Cobra Insurance Payments	0.00	0.00	0.00	0.00	0.00	0.00	100.0%
26	44170	000	01001	000	Miscellaneous Refunds - Courthouse	0.00	0.00	0.00	0.00	201,090.44	-201,090.44	100.0%
26	44170	000	01003	000	Miscellaneous Refunds - Garbage	0.00	0.00	0.00	0.00	0.00	0.00	100.0%
26	44170	000	01004	000	Miscellaneous Refunds - Library	0.00	0.00	0.00	0.00	0.00	0.00	100.0%
26	44170	000	01009	000	Miscellaneous Refunds - E911	0.00	0.00	0.00	0.00	0.00	0.00	100.0%
26	44170	000	01010	000	Miscellaneous Refunds - Landfill	0.00	0.00	0.00	0.00	0.00	0.00	100.0%
264 44---						0.00	0.00	0.00	1,560.88	225,232.88	-225,232.88	
26	48140	000	01010	000	Contracted Services - Landfill	0.00	0.00	0.00	0.00	0.00	0.00	100.0%

REVENUE SUMMARY REPORT

May 2025-2026

HAMBLEEN COUNTY ACCOUNTS & BUDGETS

101 General Fund

Fund(s) Selected:
101; 122; 128; 151; 154;
171; 173; 176; 177; 178;

Fd	Acct	Obj	Loc	Prg Description	Budget Amount	Budget Amendments	Amended Budget	MTD Revenues	YTD Revenues	Uncollected Revenues	% of Bdgt
				264 48---	0.00	0.00	0.00	0.00	0.00	0.00	
26	49800	000	00000	000 Transfers In	0.00	0.00	0.00	0.00	0.00	0.00	100.0%
				264 49---	0.00	0.00	0.00	0.00	0.00	0.00	
Employee Insurance - General Fund#(264) Totals:					0.00	0.00	0.00	430,460.05	4,437,186.87	-4,437,186.87	

REVENUE SUMMARY REPORT

May 2025-2026

HAMBLLEN COUNTY ACCOUNTS & BUDGETS

101 General Fund

Fund(s) Selected:
101; 122; 128; 151; 154;
171; 173; 176; 177; 178;

Fd	Acct	Obj	Loc	Prg Description	Budget Amount	Budget Amendments	Amended Budget	MTD Revenues	YTD Revenues	Uncollected Revenues	% of Bdgt
33	43102	000	00000	000 Other Employee Benefit Charges/Contributions	0.00	0.00	0.00	3,779.71	36,143.65	-36,143.65	100.0%
			334	43---	<u>0.00</u>	<u>0.00</u>	<u>0.00</u>	<u>3,779.71</u>	<u>36,143.65</u>	<u>-36,143.65</u>	
33	44110	000	00000	000 Investment Income	0.00	0.00	0.00	0.00	0.00	0.00	100.0%
33	44170	000	00000	000 Miscellaneous Refunds	0.00	0.00	0.00	50.00	175.26	-175.26	100.0%
			334	44---	<u>0.00</u>	<u>0.00</u>	<u>0.00</u>	<u>50.00</u>	<u>175.26</u>	<u>-175.26</u>	
Employee Benefit Trust Fund #(334) Totals:					<u><u>0.00</u></u>	<u><u>0.00</u></u>	<u><u>0.00</u></u>	<u><u>3,829.71</u></u>	<u><u>36,318.91</u></u>	<u><u>-36,318.91</u></u>	

REVENUE SUMMARY REPORT

May 2025-2026

HAMBLEEN COUNTY ACCOUNTS & BUDGETS

101 General Fund

Fund(s) Selected:
101; 122; 128; 151; 154;
171; 173; 176; 177; 178;

Fd	Acct	Obj	Loc	Prg	Description	Budget Amount	Budget Amendments	Amended Budget	MTD Revenues	YTD Revenues	Uncollected Revenues	% of Bdgt
35	40210	000	00000	000	Local Option Sales Tax	0.00	0.00	0.00	1,814,993.90	18,794,650.35	-18,794,650.35	100.0%
			351	40---		0.00	0.00	0.00	1,814,993.90	18,794,650.	-18,794,650.	
			Cities - Sales Tax Fund #(351) Totals:			0.00	0.00	0.00	1,814,993.90	18,794,650.	-18,794,650.	

REVENUE SUMMARY REPORT

May 2025-2026

HAMBLLEN COUNTY ACCOUNTS & BUDGETS

Fund(s) Selected:
116

116 Sanitation

Fd	Acct	Obj	Loc	Prg	Description	Budget Amount	Budget Amendments	Amended Budget	MTD Revenues	YTD Revenues	Uncollected Revenues	% of Bdgt
11	40110	000	00000	000	Current Property Tax	1,500,000.00	0.00	1,500,000.00	23,847.34	1,817,854.02	-317,854.02	121.1%
11	40120	000	00000	000	Trustee's Collections - Prior Year	20,000.00	0.00	20,000.00	-44.59	30,882.86	-10,882.86	154.4%
11	40125	000	00000	000	Trustee's Collections - Bankruptcy	700.00	0.00	700.00	27.89	519.32	180.68	74.18%
11	40130	000	00000	000	Circuit Clerk/Clerk & Master Collections-Prior Yrs	3,000.00	0.00	3,000.00	2,016.89	8,090.96	-5,090.96	269.6%
11	40140	000	00000	000	Interest And Penalty	12,000.00	0.00	12,000.00	1,736.44	9,022.45	2,977.55	75.18%
11	40161	000	00000	000	Payments In-Lieu-Of Taxes - T.V.A.	0.00	0.00	0.00	0.00	0.00	0.00	100.0%
11	40163	000	00000	000	Payments In-Lieu of Taxes - Other	0.00	0.00	0.00	0.00	95.15	-95.15	100.0%
11	40210	000	00000	000	Local Option Sales Tax	1,950,000.00	0.00	1,950,000.00	200,834.25	1,845,466.89	104,533.11	94.63%
11	40330	000	00000	000	Wholesale Beer Tax	118,600.00	0.00	118,600.00	10,797.67	93,575.27	25,024.73	78.89%
					116 40---	3,604,300.00	0.00	3,604,300.00	239,215.89	3,805,506.92	-201,206.92	
11	41510	000	00000	000	Beer Permits	1,880.00	0.00	1,880.00	0.00	1,900.00	-20.00	101.0%
					116 41---	1,880.00	0.00	1,880.00	0.00	1,900.00	-20.00	
11	44110	000	00000	000	Investment Income	500,000.00	0.00	500,000.00	0.00	500,000.00	0.00	100.0%
11	44130	000	00000	000	Sale Of Materials And Supplies	10,000.00	0.00	10,000.00	900.00	19,700.00	-9,700.00	197.0%
11	44170	000	00000	000	Miscellaneous Refunds	0.00	0.00	0.00	0.00	0.00	0.00	100.0%
11	44180	000	00000	000	Expenditure Credits	0.00	0.00	0.00	0.00	0.00	0.00	100.0%
11	44530	000	00000	000	Sale Of Equipment	0.00	0.00	0.00	0.00	27,454.00	-27,454.00	100.0%
					116 44---	510,000.00	0.00	510,000.00	900.00	547,154.00	-37,154.00	
11	46190	000	00000	000	Other General Government Grants	0.00	0.00	0.00	0.00	1,000,000.00	-1,000,000.00	100.0%
11	46830	000	00000	000	Beer Tax	18,000.00	0.00	18,000.00	0.00	16,956.22	1,043.78	94.20%
					116 46---	18,000.00	0.00	18,000.00	0.00	1,016,956.22	-998,956.22	
11	47303	000	00000	000	COVID-19 Grant	0.00	0.00	0.00	0.00	0.00	0.00	100.0%

REVENUE SUMMARY REPORT

May 2025-2026

HAMBLLEN COUNTY ACCOUNTS & BUDGETS

Fund(s) Selected:
116

116 Sanitation

Fd	Acct	Obj	Loc	Prg Description	Budget Amount	Budget Amendments	Amended Budget	MTD Revenues	YTD Revenues	Uncollected Revenues	% of Bdgt
				116 47---	0.00	0.00	0.00	0.00	0.00	0.00	
11	49700	000	00000	000 Insurance Recovery	0.00	50,002.20	50,002.20	0.00	50,002.20	0.00	100.0%
11	49800	000	00000	000 Operating Transfers In	0.00	0.00	0.00	0.00	0.00	0.00	100.0%
				116 49---	0.00	50,002.20	50,002.20	0.00	50,002.20	0.00	
Solid Waste/Sanitation Fund #(116) Totals:					4,134,180.00	50,002.20	4,184,182.20	240,115.89	5,421,519.34	-1,237,337.14	

REVENUE SUMMARY REPORT

May 2025-2026

HAMBLLEN COUNTY ACCOUNTS & BUDGETS

Fund(s) Selected:
131

131 Highway

Fd	Acct	Obj	Loc	Prg	Description	Budget Amount	Budget Amendments	Amended Budget	MTD Revenues	YTD Revenues	Uncollected Revenues	% of Bdgt
13	40210	000	00000	000	Local Option Sales Tax	200,000.00	0.00	200,000.00	0.00	200,000.00	0.00	100.0%
13	40280	000	00000	000	Mineral Severance Tax	70,000.00	0.00	70,000.00	0.00	51,001.63	18,998.37	72.85%
131 40---						270,000.00	0.00	270,000.00	0.00	251,001.63	18,998.37	
13	44110	000	00000	000	Investment Income	75,000.00	0.00	75,000.00	0.00	75,000.00	0.00	100.0%
13	44130	000	00000	000	Sale Of Materials And Supplies	0.00	0.00	0.00	0.00	0.00	0.00	100.0%
13	44170	000	00000	000	Miscellaneous Refunds	0.00	0.00	0.00	100.00	4,240.56	-4,240.56	100.0%
13	44180	000	00000	000	Expenditure Credits	0.00	0.00	0.00	0.00	281.60	-281.60	100.0%
13	44530	000	00000	000	Sale Of Equipment	0.00	0.00	0.00	250.00	42,839.40	-42,839.40	100.0%
13	44560	000	00000	000	Damages Recovered From Individuals	0.00	0.00	0.00	0.00	0.00	0.00	100.0%
131 44---						75,000.00	0.00	75,000.00	350.00	122,361.56	-47,361.56	
13	46420	000	00000	000	State Aid Program	0.00	0.00	0.00	0.00	0.00	0.00	100.0%
13	46851	000	00000	000	State Revenue Sharing - T.V.A.	200,000.00	0.00	200,000.00	0.00	200,000.00	0.00	100.0%
13	46920	000	00000	000	Gasoline and Motor Fuel Tax	2,375,000.00	0.00	2,375,000.00	198,444.57	1,985,228.63	389,771.37	83.58%
13	46925	000	00000	000	Hybrid/Electric Vehicle Registration Fee	20,000.00	0.00	20,000.00	3,803.01	31,191.82	-11,191.82	155.9%
13	46930	000	00000	000	Petroleum Special Tax	42,736.00	0.00	42,736.00	3,561.32	35,613.24	7,122.76	83.33%
13	46980	000	00000	000	Other State Grants	0.00	0.00	0.00	0.00	0.00	0.00	100.0%
131 46---						2,637,736.00	0.00	2,637,736.00	205,808.90	2,252,033.69	385,702.31	
13	47100	000	00000	000	Federal Through State	0.00	0.00	0.00	0.00	0.00	0.00	100.0%
13	47230	000	00000	000	Disaster Relief	0.00	0.00	0.00	250,132.80	250,132.80	-250,132.80	100.0%
13	47303	000	00000	000	COVID-19 Grant	0.00	0.00	0.00	0.00	0.00	0.00	100.0%
131 47---						0.00	0.00	0.00	250,132.80	250,132.80	-250,132.80	
13	48120	000	00000	000	Paving and Maintenance	0.00	0.00	0.00	0.00	0.00	0.00	100.0%
13	48610	000	00000	000	Donations	0.00	0.00	0.00	0.00	0.00	0.00	100.0%

REVENUE SUMMARY REPORT

May 2025-2026

HAMBLEEN COUNTY ACCOUNTS & BUDGETS

Fund(s) Selected:
131

131 Highway

Fd	Acct	Obj	Loc	Prg Description	Budget Amount	Budget Amendments	Amended Budget	MTD Revenues	YTD Revenues	Uncollected Revenues	% of Bdgt
			131	48---	0.00	0.00	0.00	0.00	0.00	0.00	
13	49700	000	00000	000 Insurance Recovery	0.00	0.00	0.00	0.00	0.00	0.00	100.0%
13	49800	000	00000	000 Transfers In	0.00	0.00	0.00	0.00	0.00	0.00	100.0%
			131	49---	0.00	0.00	0.00	0.00	0.00	0.00	
Highway/Public Works Fund (#131) Totals:					2,982,736.00	0.00	2,982,736.00	456,291.70	2,875,529.68	107,206.32	

MONTHLY CHECKS

COMMISSION APPROVAL LISTING

ACCT	OB	Name	Date	Check Nbr	Description	Amount Paid
Fund: General Fund #(101)						
51100	317	Data Processing Services	05/21/2026	1010285119	GovConnection, Inc.	11.52
51100	599	Other Charges	05/14/2026	1010285013	Citizen Tribune	749.07
51100		County Commission			Check Count: 2	Total: 760.59
51300	307	Communication	05/14/2026	1010285013	Citizen Tribune	201.90
51300	307	Communication	05/21/2026	1010285098	AT&T Mobility	43.50
51300	317	Data Processing Services	05/21/2026	1010285119	GovConnection, Inc.	23.04
51300	351	Rentals	05/21/2026	1010285103	Canon Solutions America, Inc	394.09
51300	435	Office Supplies	05/07/2026	1010284987	Sharon Robinson	250.00
51300	435	Office Supplies	05/22/2026	1010285151	Amazon Capital Services, Inc.	199.48
51300	599	Other Charges	05/07/2026	1010284989	South Marketing Group	650.00
51300	599	Other Charges	05/14/2026	1010285019	English Mountain Spring Water	15.00
51300	599	Other Charges	05/14/2026	1010285028	HomeTrust Bank	88.80
51300	599	Other Charges	05/21/2026	1010285112	English Mountain Spring Water	22.50
51300		County Mayor/Executive			Check Count: 10	Total: 1,888.31
51400	331	Legal Services	05/14/2026	1010285040	Owings, Wilson & Coleman	24,572.85
51400	331	Legal Services	05/14/2026	1010285049	Taylor Law Firm	54.00
51400	331	Legal Services	05/21/2026	1010285104	Capps & Byrd LLP	1,828.75
51400		County Attorney			Check Count: 3	Total: 26,455.60
51500	193	Election Worker	05/14/2026	1010285053	CONNIE ARMSTRONG	50.00
51500	193	Election Worker	05/14/2026	1010285054	Ronnie Banks	50.00
51500	193	Election Worker	05/14/2026	1010285055	BARRY DOUGLAS BEDDOR	140.00
51500	193	Election Worker	05/14/2026	1010285056	VIRGINIA MARY BLANKEMEIER	140.00
51500	193	Election Worker	05/14/2026	1010285057	CONNIE BLANKEN	50.00
51500	193	Election Worker	05/14/2026	1010285058	DON E BOLER	140.00
51500	193	Election Worker	05/14/2026	1010285059	FRANCES RENEE BROTHERS	140.00

COMMISSION APPROVAL LISTING

ACCT	OB	Name	Date	Check Nbr	Description	Amount Paid
Fund: General Fund #(101)						
51500	193	Election Worker	05/14/2026	1010285060	JEFFREY A BURLESON	140.00
51500	193	Election Worker	05/14/2026	1010285061	Rick Carson	50.00
51500	193	Election Worker	05/14/2026	1010285062	Robin Cooper	50.00
51500	193	Election Worker	05/14/2026	1010285063	Donna Cox	140.00
51500	193	Election Worker	05/14/2026	1010285064	James Robert Cox	140.00
51500	193	Election Worker	05/14/2026	1010285065	BONNIE LOU DE COSTA	50.00
51500	193	Election Worker	05/14/2026	1010285066	Jason Dixon	50.00
51500	193	Election Worker	05/14/2026	1010285067	MARLO MASENGILL DUDLEY	140.00
51500	193	Election Worker	05/14/2026	1010285068	Carla Ellison	50.00
51500	193	Election Worker	05/14/2026	1010285069	SANDY GILBERT	50.00
51500	193	Election Worker	05/14/2026	1010285070	Deborah C Hammond	140.00
51500	193	Election Worker	05/14/2026	1010285071	TERESA HELTON	50.00
51500	193	Election Worker	05/14/2026	1010285072	JENNIFER F HERNON	140.00
51500	193	Election Worker	05/14/2026	1010285073	CHARLES DONALD HODGES	140.00
51500	193	Election Worker	05/14/2026	1010285074	Linda Turner Hodges	140.00
51500	193	Election Worker	05/14/2026	1010285075	MARK HODGES	50.00
51500	193	Election Worker	05/14/2026	1010285076	SUE T JUSTIS	140.00
51500	193	Election Worker	05/14/2026	1010285077	KIRK KNOX	170.00
51500	193	Election Worker	05/14/2026	1010285078	JENNIFER LYNN LAVIN	140.00
51500	193	Election Worker	05/14/2026	1010285079	Paul Anthony Lubotina	140.00
51500	193	Election Worker	05/14/2026	1010285080	BRENDA K LUTZ	140.00
51500	193	Election Worker	05/14/2026	1010285081	GRACE ELIZABETH MCCANN	140.00
51500	193	Election Worker	05/14/2026	1010285082	Jon L Muller	140.00
51500	193	Election Worker	05/14/2026	1010285083	ROCKY NORTON	50.00
51500	193	Election Worker	05/14/2026	1010285084	SAMUEL ROBERT ODELL	140.00
51500	193	Election Worker	05/14/2026	1010285085	CLEMENCIA OLER	50.00
51500	193	Election Worker	05/14/2026	1010285086	SHARON G PRITCHARD	140.00

COMMISSION APPROVAL LISTING

ACCT	OB	Name	Date	Check Nbr	Description	Amount Paid
Fund: General Fund #(101)						
51500	193	Election Worker	05/14/2026	1010285087	MARIA REYNA	50.00
51500	193	Election Worker	05/14/2026	1010285088	Jeremy Seal	50.00
51500	193	Election Worker	05/14/2026	1010285089	Sandra Seal	50.00
51500	193	Election Worker	05/14/2026	1010285090	Carolyn Suzanne Terry	140.00
51500	193	Election Worker	05/14/2026	1010285091	Patience A Thompson	140.00
51500	193	Election Worker	05/14/2026	1010285092	LOUIA WESTON	50.00
51500	193	Election Worker	05/14/2026	1010285093	JAMES B WILLS	140.00
51500	193	Election Worker	05/14/2026	1010285094	Ronald E Yount	140.00
51500	193	Election Worker	05/14/2026	9101001426	MARTHA M ANDERSON	140.00
51500	193	Election Worker	05/14/2026	9101001427	Teresa B Ayers	140.00
51500	193	Election Worker	05/14/2026	9101001428	Crystle Hall Bacon	140.00
51500	193	Election Worker	05/14/2026	9101001429	VIRGINIA M BENTLEY	140.00
51500	193	Election Worker	05/14/2026	9101001430	THOMAS BUCHANAN	170.00
51500	193	Election Worker	05/14/2026	9101001431	Kelly A Campbell	140.00
51500	193	Election Worker	05/14/2026	9101001432	Dawn P Cantwell	140.00
51500	193	Election Worker	05/14/2026	9101001433	Melissa Rae Carson	140.00
51500	193	Election Worker	05/14/2026	9101001434	Robert J Carter	140.00
51500	193	Election Worker	05/14/2026	9101001435	GINGER F COLE	140.00
51500	193	Election Worker	05/14/2026	9101001436	Dwayne C Collins	170.00
51500	193	Election Worker	05/14/2026	9101001437	RHONDA D COLLINS	140.00
51500	193	Election Worker	05/14/2026	9101001438	Christy Cowan	140.00
51500	193	Election Worker	05/14/2026	9101001439	MARY J DAACK	170.00
51500	193	Election Worker	05/14/2026	9101001440	Joyce A Damon	140.00
51500	193	Election Worker	05/14/2026	9101001441	RAYMOND G DAMON	140.00
51500	193	Election Worker	05/14/2026	9101001442	ELIZABETH H DOBBINS	170.00
51500	193	Election Worker	05/14/2026	9101001443	ERIC F DREHER	140.00
51500	193	Election Worker	05/14/2026	9101001444	Dwaine Evans	140.00

COMMISSION APPROVAL LISTING

ACCT	OB	Name	Date	Check Nbr	Description	Amount Paid
Fund: General Fund #(101)						
51500	193	Election Worker	05/14/2026	9101001445	Mark Douglas Fullington	170.00
51500	193	Election Worker	05/14/2026	9101001446	Nancy B Goan	140.00
51500	193	Election Worker	05/14/2026	9101001447	SUSAN H GREENE	140.00
51500	193	Election Worker	05/14/2026	9101001448	Susan S Greene	140.00
51500	193	Election Worker	05/14/2026	9101001449	Amy Hale	140.00
51500	193	Election Worker	05/14/2026	9101001450	Pamela A Hall	140.00
51500	193	Election Worker	05/14/2026	9101001451	Dean Hammer	170.00
51500	193	Election Worker	05/14/2026	9101001452	AMY R HANCOCK	140.00
51500	193	Election Worker	05/14/2026	9101001453	David M Harrell	170.00
51500	193	Election Worker	05/14/2026	9101001454	SUE J HARRELL	140.00
51500	193	Election Worker	05/14/2026	9101001455	Carolyn Harris	140.00
51500	193	Election Worker	05/14/2026	9101001456	CLEO M HARRIS	140.00
51500	193	Election Worker	05/14/2026	9101001457	Virginia L Harris	140.00
51500	193	Election Worker	05/14/2026	9101001458	Chris Horn	170.00
51500	193	Election Worker	05/14/2026	9101001459	Dennie D Humphreys	140.00
51500	193	Election Worker	05/14/2026	9101001460	Sondra L Humphreys	140.00
51500	193	Election Worker	05/14/2026	9101001461	KATHY ANN JACKSON	140.00
51500	193	Election Worker	05/14/2026	9101001462	Cynthia A Jenkins	140.00
51500	193	Election Worker	05/14/2026	9101001463	Pamela M Kimbrough	140.00
51500	193	Election Worker	05/14/2026	9101001464	SUSAN D KUTBAY	140.00
51500	193	Election Worker	05/14/2026	9101001465	Linda Marie Lande	25.00
51500	193	Election Worker	05/14/2026	9101001466	Franklin H Lee	140.00
51500	193	Election Worker	05/14/2026	9101001467	VICKI M MAHAN	140.00
51500	193	Election Worker	05/14/2026	9101001468	LINDA G MALONEY	0.00**
51500	193	Election Worker	05/14/2026	9101001469	David R Marshall	140.00
51500	193	Election Worker	05/14/2026	9101001470	John E Martin	140.00
51500	193	Election Worker	05/14/2026	9101001471	JOE H MEHAFFEY	170.00

**Originally paid by ACH, however her account was closed. Voided original payment and issued new payment by check.

COMMISSION APPROVAL LISTING

ACCT	OB	Name	Date	Check Nbr	Description	Amount Paid
Fund: General Fund #(101)						
51500	193	Election Worker	05/14/2026	9101001472	Janice F Mills	140.00
51500	193	Election Worker	05/14/2026	9101001473	Patricia Little Muller	140.00
51500	193	Election Worker	05/14/2026	9101001474	Eugenia L Newman	140.00
51500	193	Election Worker	05/14/2026	9101001475	CAROL W PETERSON	140.00
51500	193	Election Worker	05/14/2026	9101001476	Samuel Lynn Phillips	170.00
51500	193	Election Worker	05/14/2026	9101001477	MELINDA REESE	140.00
51500	193	Election Worker	05/14/2026	9101001478	AMY L ROPER	170.00
51500	193	Election Worker	05/14/2026	9101001479	Karen A Scarbro	140.00
51500	193	Election Worker	05/14/2026	9101001480	Barbara Semeraro	140.00
51500	193	Election Worker	05/14/2026	9101001481	JERRY L SHEPARD	170.00
51500	193	Election Worker	05/14/2026	9101001482	Diana Skidmore	170.00
51500	193	Election Worker	05/14/2026	9101001483	Virginia Smith	140.00
51500	193	Election Worker	05/14/2026	9101001484	ANGELA G SNODGRASS	140.00
51500	193	Election Worker	05/14/2026	9101001485	Hannah Ann Starnes	170.00
51500	193	Election Worker	05/14/2026	9101001486	Connie Lynette Strickland	140.00
51500	193	Election Worker	05/14/2026	9101001487	CHARLES OTIS STUBBLEFIELD	140.00
51500	193	Election Worker	05/14/2026	9101001488	Claudia R Thaxton	140.00
51500	193	Election Worker	05/14/2026	9101001489	Cynthia C Thompson	140.00
51500	193	Election Worker	05/14/2026	9101001490	Ralph E Thompson	140.00
51500	193	Election Worker	05/14/2026	9101001491	ROSALIND RM THOMPSON	25.00
51500	193	Election Worker	05/14/2026	9101001492	Rachel Vazquez	140.00
51500	193	Election Worker	05/14/2026	9101001493	EDITH O WEBB	140.00
51500	193	Election Worker	05/14/2026	9101001494	Robert Wheeler	170.00
51500	193	Election Worker	05/14/2026	9101001495	Sheila M Wheeler	170.00
51500	193	Election Worker	05/14/2026	9101001496	John D Whitten	140.00
51500	193	Election Worker	05/14/2026	9101001497	Pam G Wisecarver	140.00
51500	193	Election Worker	05/14/2026	9101001498	Amanda Helen Wyke	140.00

COMMISSION APPROVAL LISTING

ACCT	OB	Name	Date	Check Nbr	Description	Amount Paid
Fund: General Fund #(101)						
51500	193	Election Worker	05/14/2026	9101001499	Lethia M Yeary	140.00
51500	307	Communication	05/21/2026	1010285098	AT&T Mobility	43.50
51500	312	Contracts With Private Agencies	05/07/2026	1010284995	Robert Tucker	29.74
51500	312	Contracts With Private Agencies	05/21/2026	1010285129	Microvote Corporation	5,100.00
51500	312	Contracts With Private Agencies	05/14/2026	9101001419	Landree Brotherton	1,830.00
51500	312	Contracts With Private Agencies	05/14/2026	9101001421	Justin Hinton	1,830.00
51500	317	Data Processing Services	05/21/2026	1010285119	GovConnection, Inc.	34.56
51500	332	Legal Notices, Recording And Court Costs	05/14/2026	1010285013	Citizen Tribune	4,633.99
51500	351	Rentals	05/07/2026	1010284967	Margaret Gardner	500.00
51500	351	Rentals	05/21/2026	1010285103	Canon Solutions America, Inc	84.92
51500	355	Travel	05/14/2026	9101001424	E C Reed	39.15
51500	435	Office Supplies	05/14/2026	1010285019	English Mountain Spring Water	7.50
51500	435	Office Supplies	05/21/2026	1010285112	English Mountain Spring Water	15.00
51500		Election Commission		Check Count: 128	Total:	28,998.36
51600	317	Data Processing Services	05/21/2026	1010285119	GovConnection, Inc.	80.64
51600	435	Office Supplies	05/14/2026	1010285033	Mildred's Florist & Gifts, Inc.	58.00
51600	435	Office Supplies	05/21/2026	1010285114	Evans Office Supply Co	179.00
51600	435	Office Supplies	05/21/2026	1010285137	Rix Copies	10.98
51600	709	Data Processing Equipment	05/14/2026	1010285029	i3 Verticals LLC	1,635.56
51600		Register Of Deeds		Check Count: 5	Total:	1,964.18
51720	307	Communication	05/07/2026	1010284998	Verizon Wireless	68.00
51720	307	Communication	05/21/2026	1010285098	AT&T Mobility	130.50
51720	312	Contracts With Private Agencies	05/07/2026	1010284955	City of Morristown	4,100.00
51720	317	Data Processing Services	05/21/2026	1010285119	GovConnection, Inc.	79.75
51720	338	Maintenance And Repair Services - Vehicles	05/14/2026	1010285045	Spotless Brands Intermediate I, LLC	15.00
51720	351	Rentals	05/21/2026	1010285103	Canon Solutions America, Inc	59.50

COMMISSION APPROVAL LISTING

ACCT	OB	Name	Date	Check Nbr	Description	Amount Paid
Fund: General Fund #(101)						
51720	425	Gasoline	05/21/2026	1010285117	Fuelman	152.20
51720	435	Office Supplies	05/21/2026	1010285114	Evans Office Supply Co	247.50
51720	435	Office Supplies	05/22/2026	1010285151	Amazon Capital Services, Inc.	353.57
51720	Planning			Check Count:	9	Total: 5,206.02
51810	307	Communication	05/21/2026	1010285097	AT&T	658.04
51810	307	Communication	05/21/2026	1010285098	AT&T Mobility	286.72
51810	307	Communication	05/21/2026	1010285128	MetTel	1,028.77
51810	317	Data Processing Services	05/21/2026	1010285119	GovConnection, Inc.	11.52
51810	334	Maintenance Agreements	05/14/2026	1010285037	Murrell Burglar Alarm Co Inc	136.00
51810	334	Maintenance Agreements	05/14/2026	1010285043	SEI Waste, LLC	92.20
51810	335	Maintenance And Repair Service - Buildings	05/07/2026	1010284971	Gutters & More	400.00
51810	335	Maintenance And Repair Service - Buildings	05/07/2026	1010284978	Lowe's	764.57
51810	335	Maintenance And Repair Service - Buildings	05/07/2026	1010284986	NAPA Auto Parts Of Morristown	95.17
51810	335	Maintenance And Repair Service - Buildings	05/14/2026	1010285014	City Electric Supply	52.99
51810	335	Maintenance And Repair Service - Buildings	05/14/2026	1010285042	Dylan Samples	480.00
51810	335	Maintenance And Repair Service - Buildings	05/14/2026	1010285047	T.E.G. Enterprises, Inc	285.00
51810	335	Maintenance And Repair Service - Buildings	05/21/2026	1010285106	City Electric Supply	56.39
51810	335	Maintenance And Repair Service - Buildings	05/21/2026	1010285146	William Mitchell Trent	950.00
51810	335	Maintenance And Repair Service - Buildings	05/22/2026	1010285151	Amazon Capital Services, Inc.	151.97
51810	335	Maintenance And Repair Service - Buildings	05/28/2026	1010285156	Ricky S Coffey	600.00
51810	338	Maintenance And Repair Services - Vehicles	05/14/2026	1010285045	Spotless Brands Intermediate I, LLC	45.00
51810	399	Other Contracted Services	05/14/2026	1010285019	English Mountain Spring Water	15.50
51810	399	Other Contracted Services	05/21/2026	1010285112	English Mountain Spring Water	53.00
51810	410	Custodial Supplies	05/07/2026	1010284996	Unifirst Corp	310.93
51810	410	Custodial Supplies	05/07/2026	1010285000	Wet Washing Equipment Technologies	1,146.33
51810	415	Electricity	05/07/2026	1010284982	Morristown Utilities	3,297.00

COMMISSION APPROVAL LISTING

ACCT	OB	Name	Date	Check Nbr	Description	Amount Paid
Fund: General Fund #(101)						
51810	415	Electricity	05/14/2026	1010285035	Morristown Utilities	15,563.00
51810	415	Electricity	05/21/2026	1010285131	Morristown Utilities	4,549.00
51810	415	Electricity	05/28/2026	1010285162	Morristown Utilities	14,933.00
51810	425	Gasoline	05/21/2026	1010285117	Fuelman	657.98
51810	434	Natural Gas	05/07/2026	1010284953	Atmos Energy	122.59
51810	434	Natural Gas	05/14/2026	1010285007	Atmos Energy	271.00
51810	434	Natural Gas	05/21/2026	1010285099	Atmos Energy	7,460.79
51810	451	Uniforms	05/07/2026	1010284996	Unifirst Corp	270.20
51810	717	Maintenance Equipment	05/22/2026	1010285151	Amazon Capital Services, Inc.	277.97
51810		Other Facilities		Check Count:	29	Total: 55,022.63
51910	307	Communication	05/21/2026	1010285098	AT&T Mobility	40.96
51910	317	Data Processing Services	05/21/2026	1010285119	GovConnection, Inc.	23.04
51910	351	Rentals	05/21/2026	1010285103	Canon Solutions America, Inc	85.22
51910	435	Office Supplies	05/07/2026	1010284968	Gaylord Bros	39.32
51910	435	Office Supplies	05/21/2026	1010285114	Evans Office Supply Co	79.78
51910	435	Office Supplies	05/14/2026	9101001422	Cynthia R Lane	119.00
51910		Preservation Of Records		Check Count:	6	Total: 387.32
52100	312	Contracts With Private Agencies	05/14/2026	9101001418	William H Brittain	1,590.00
52100	317	Data Processing Services	05/21/2026	1010285119	GovConnection, Inc.	92.16
52100	320	Dues And Memberships	05/14/2026	1010285028	HomeTrust Bank	299.00
52100	435	Office Supplies	05/22/2026	1010285151	Amazon Capital Services, Inc.	29.49
52100		Accounting And Budgeting		Check Count:	4	Total: 2,010.65
52300	307	Communication	05/21/2026	1010285098	AT&T Mobility	67.48
52300	317	Data Processing Services	05/21/2026	1010285119	GovConnection, Inc.	80.64
52300	338	Maintenance And Repair Services - Vehicles	05/14/2026	1010285045	Spotless Brands Intermediate I, LLC	30.00

COMMISSION APPROVAL LISTING

ACCT	OB	Name	Date	Check Nbr	Description	Amount Paid
Fund: General Fund #(101)						
52300	425	Gasoline	05/21/2026	1010285117	Fuelman	269.38
52300	435	Office Supplies	05/14/2026	1010285019	English Mountain Spring Water	60.50
52300	435	Office Supplies	05/21/2026	1010285112	English Mountain Spring Water	53.00
52300		Property Assessor's Office		Check Count:	6	Total: 561.00
52310	312	Contracts With Private Agencies	05/14/2026	1010285048	Tax Management Associates, Inc	36,225.00
52310	331	Legal Services	05/14/2026	1010285013	Citizen Tribune	238.62
52310	351	Rentals	05/21/2026	1010285103	Canon Solutions America, Inc	122.08
52310	435	Office Supplies	05/21/2026	1010285114	Evans Office Supply Co	327.83
52310		Reappraisal Program		Check Count:	4	Total: 36,913.53
52400	317	Data Processing Services	05/21/2026	1010285119	GovConnection, Inc.	69.12
52400	351	Rentals	05/21/2026	1010285103	Canon Solutions America, Inc	65.69
52400	435	Office Supplies	05/07/2026	1010284972	Hamblen County Clerk	14.00
52400	435	Office Supplies	05/14/2026	1010285019	English Mountain Spring Water	15.50
52400	435	Office Supplies	05/21/2026	1010285112	English Mountain Spring Water	8.00
52400		County Trustee's Office		Check Count:	5	Total: 172.31
52500	307	Communication	05/21/2026	1010285097	AT&T	47.47
52500	307	Communication	05/21/2026	1010285098	AT&T Mobility	40.96
52500	317	Data Processing Services	05/14/2026	1010285029	i3 Verticals LLC	742.00
52500	317	Data Processing Services	05/21/2026	1010285119	GovConnection, Inc.	237.94
52500	351	Rentals	05/14/2026	1010285047	T.E.G. Enterprises, Inc	95.00
52500	351	Rentals	05/21/2026	1010285103	Canon Solutions America, Inc	111.34
52500	399	Other Contracted Services	05/14/2026	1010285008	Blue Ridge Document Shredding	50.00
52500	399	Other Contracted Services	05/21/2026	1010285102	Blue Ridge Document Shredding	190.00
52500	435	Office Supplies	05/14/2026	1010285019	English Mountain Spring Water	83.00
52500	435	Office Supplies	05/14/2026	1010285029	i3 Verticals LLC	528.00

COMMISSION APPROVAL LISTING

ACCT	OB	Name	Date	Check Nbr	Description	Amount Paid
Fund: General Fund #(101)						
52500	435	Office Supplies	05/21/2026	1010285112	English Mountain Spring Water	38.00
52500	435	Office Supplies	05/21/2026	1010285114	Evans Office Supply Co	1,240.85
52500	435	Office Supplies	05/22/2026	1010285151	Amazon Capital Services, Inc.	259.99
52500	709	Data Processing Equipment	05/14/2026	1010285029	i3 Verticals LLC	440.00
52500		County Clerk's Office		Check Count: 12	Total:	4,104.55
52600	307	Communication	05/21/2026	1010285098	AT&T Mobility	87.00
52600	312	Contracts With Private Agencies	05/14/2026	1010285015	CyberFOX, LLC	308.70
52600	312	Contracts With Private Agencies	05/14/2026	1010285038	MUS Fibernet	570.10
52600	317	Data Processing Services	05/07/2026	1010284995	Robert Tucker	99.99
52600	317	Data Processing Services	05/14/2026	1010285028	HomeTrust Bank	7.00
52600	317	Data Processing Services	05/21/2026	1010285119	GovConnection, Inc.	85.07
52600	334	Maintenance Agreements	05/28/2026	1010285165	White Rock Security Group, LLC	3,920.00
52600	709	Data Processing Equipment	05/07/2026	1010284978	Lowe's	311.27
52600	709	Data Processing Equipment	05/14/2026	1010285010	CDW Government, Inc	5,219.51
52600	709	Data Processing Equipment	05/21/2026	1010285139	SOS Computers, LLC	26,160.00
52600	709	Data Processing Equipment	05/22/2026	1010285151	Amazon Capital Services, Inc.	79.96
52600		Data Processing		Check Count: 11	Total:	36,848.60
53100	194	Jury And Witness Expense	05/14/2026	1010285016	Dutch Restaurant Group, LLC	176.00
53100	194	Jury And Witness Expense	05/28/2026	1010285157	Dutch Restaurant Group, LLC	176.00
53100	307	Communication	05/21/2026	1010285097	AT&T	39.22
53100	307	Communication	05/21/2026	1010285098	AT&T Mobility	84.46
53100	317	Data Processing Services	05/21/2026	1010285119	GovConnection, Inc.	295.83
53100	332	Legal Notices, Recording And Court Costs	05/14/2026	1010285013	Citizen Tribune	91.02
53100	349	Printing, Stationery And Forms	05/28/2026	1010285164	Shred-It	30.00
53100	351	Rentals	05/21/2026	1010285103	Canon Solutions America, Inc	275.68
53100	435	Office Supplies	05/14/2026	1010285028	HomeTrust Bank	53.11

COMMISSION APPROVAL LISTING

ACCT	OB	Name	Date	Check Nbr	Description	Amount Paid
Fund: General Fund #(101)						
53100	435	Office Supplies	05/21/2026	1010285114	Evans Office Supply Co	1,027.02
53100	435	Office Supplies	05/22/2026	1010285151	Amazon Capital Services, Inc.	479.03
53100		Circuit Court			Check Count: 11	Total: 2,727.37
53300	317	Data Processing Services	05/21/2026	1010285119	GovConnection, Inc.	23.04
53300	320	Dues And Memberships	05/14/2026	9101001420	Wayne Douglas Collins	270.00
53300	399	Other Contracted Services	05/14/2026	9101001425	Blake E Sempkowski	409.40
53300	399	Other Contracted Services	05/21/2026	9101001501	Blake E Sempkowski	270.00
53300	435	Office Supplies	05/21/2026	1010285114	Evans Office Supply Co	63.90
53300	435	Office Supplies	05/21/2026	1010285139	SOS Computers, LLC	294.00
53300		General Sessions Court			Check Count: 6	Total: 1,330.34
53330	307	Communication	05/21/2026	1010285098	AT&T Mobility	106.21
53330	317	Data Processing Services	05/21/2026	1010285119	GovConnection, Inc.	92.16
53330	351	Rentals	05/21/2026	1010285103	Canon Solutions America, Inc	80.36
53330	399	Other Contracted Services	05/14/2026	1010285022	Herbert L Gilbert	176.00
53330	425	Gasoline	05/21/2026	1010285117	Fuelman	322.89
53330	435	Office Supplies	05/14/2026	1010285019	English Mountain Spring Water	15.00
53330	435	Office Supplies	05/21/2026	1010285112	English Mountain Spring Water	15.00
53330		Drug Court			Check Count: 7	Total: 807.62
53400	307	Communication	05/21/2026	1010285097	AT&T	73.90
53400	351	Rentals	05/21/2026	1010285103	Canon Solutions America, Inc	93.47
53400	435	Office Supplies	05/14/2026	1010285019	English Mountain Spring Water	38.00
53400	435	Office Supplies	05/21/2026	1010285112	English Mountain Spring Water	45.50
53400		Chancery Court			Check Count: 4	Total: 250.87
53500	307	Communication	05/21/2026	1010285098	AT&T Mobility	130.50

COMMISSION APPROVAL LISTING

ACCT	OB	Name	Date	Check Nbr	Description	Amount Paid
Fund: General Fund #(101)						
53500	317	Data Processing Services	05/21/2026	1010285119	GovConnection, Inc.	57.60
53500	351	Rentals	05/21/2026	1010285103	Canon Solutions America, Inc	66.75
53500	422	Food Supplies	05/14/2026	1010285019	English Mountain Spring Water	15.00
53500	422	Food Supplies	05/14/2026	1010285028	HomeTrust Bank	438.09
53500	422	Food Supplies	05/21/2026	1010285112	English Mountain Spring Water	7.50
53500	435	Office Supplies	05/14/2026	1010285003	Allegra - Morristown	343.32
53500	435	Office Supplies	05/21/2026	1010285114	Evans Office Supply Co	243.00
53500		Juvenile Court		Check Count:	8	Total: 1,301.76
53900	307	Communication	05/21/2026	1010285098	AT&T Mobility	81.92
53900	351	Rentals	05/21/2026	1010285103	Canon Solutions America, Inc	60.43
53900	355	Travel	05/14/2026	1010285028	HomeTrust Bank	154.28
53900	368	Drug Treatment	05/14/2026	1010285001	Abundant Hope Ministries	215.00
53900	368	Drug Treatment	05/21/2026	1010285143	Third Judicial District Recovery Support Services Inc	2,000.00
53900	425	Gasoline	05/21/2026	1010285117	Fuelman	58.62
53900		Other Admin Of Justice - Mental Health		Check Count:	6	Total: 2,570.25
53910	307	Communication	05/21/2026	1010285098	AT&T Mobility	163.84
53910	317	Data Processing Services	05/21/2026	1010285119	GovConnection, Inc.	46.08
53910	349	Printing, Stationery And Forms	05/21/2026	1010285114	Evans Office Supply Co	405.00
53910	435	Office Supplies	05/22/2026	1010285151	Amazon Capital Services, Inc.	179.79
53910		Probation Services		Check Count:	4	Total: 794.71
53920	451	Uniforms	05/07/2026	1010284966	Galls, LLC	2,652.90
53920	524	In Service/Staff Development	05/07/2026	1010284975	Hillbilly's Cabin Restaurant	3,150.00
53920	524	In Service/Staff Development	05/21/2026	1010285150	Walters State Comm College	6,080.00
53920		Courtroom Security		Check Count:	3	Total: 11,882.90

COMMISSION APPROVAL LISTING

ACCT	OB	Name	Date	Check Nbr	Description	Amount Paid
Fund: General Fund #(101)						
54110	307	Communication	05/07/2026	1010284998	Verizon Wireless	1,190.00
54110	307	Communication	05/21/2026	1010285097	AT&T	879.20
54110	307	Communication	05/21/2026	1010285098	AT&T Mobility	1,535.46
54110	317	Data Processing Services	05/21/2026	1010285119	GovConnection, Inc.	876.67
54110	320	Dues And Memberships	05/14/2026	1010285050	TN Sheriffs' Association, Inc	2,500.00
54110	334	Maintenance Agreements	05/14/2026	1010285028	HomeTrust Bank	109.74
54110	338	Maintenance And Repair Services - Vehicles	05/07/2026	1010284979	M & M Body Shop	1,678.20
54110	338	Maintenance And Repair Services - Vehicles	05/14/2026	1010285045	Spotless Brands Intermediate I, LLC	515.00
54110	338	Maintenance And Repair Services - Vehicles	05/21/2026	1010285111	Elite Automotive Center	3,633.77
54110	338	Maintenance And Repair Services - Vehicles	05/21/2026	1010285115	Express Lane West / Express Lane East	112.63
54110	338	Maintenance And Repair Services - Vehicles	05/21/2026	1010285138	RJK Automotive Enterprises Inc	6,293.38
54110	348	Postal Charges	05/14/2026	1010285028	HomeTrust Bank	293.97
54110	351	Rentals	05/14/2026	1010285047	T.E.G. Enterprises, Inc	85.00
54110	351	Rentals	05/21/2026	1010285103	Canon Solutions America, Inc	80.43
54110	353	Towing Services	05/07/2026	1010284990	Sunset Towing	55.00
54110	355	Travel	05/14/2026	9101001423	Pamela M Phillips	170.00
54110	399	Other Contracted Services	05/07/2026	1010284992	Transunion Risk & Alternative	129.75
54110	399	Other Contracted Services	05/14/2026	1010285037	Murrell Burglar Alarm Co Inc	29.00
54110	425	Gasoline	05/21/2026	1010285117	Fuelman	15,451.16
54110	431	Law Enforcement Supplies	05/22/2026	1010285151	Amazon Capital Services, Inc.	1,705.35
54110	433	Lubricants	05/21/2026	1010285115	Express Lane West / Express Lane East	241.86
54110	435	Office Supplies	05/21/2026	1010285114	Evans Office Supply Co	418.41
54110	435	Office Supplies	05/22/2026	1010285151	Amazon Capital Services, Inc.	238.27
54110	450	Tires And Tubes	05/07/2026	1010284952	Airport Tire	668.00
54110	450	Tires And Tubes	05/21/2026	1010285135	Porter's Tire Store Inc.	19.95
54110	451	Uniforms	05/14/2026	1010285023	Gulf States Distributors	163.00
54110	451	Uniforms	05/21/2026	1010285118	Galls, LLC	338.20

COMMISSION APPROVAL LISTING

ACCT	OB	Name	Date	Check Nbr	Description	Amount Paid
Fund: General Fund #(101)						
54110	524	In Service/Staff Development	05/07/2026	1010284999	Walters State Comm College	325.00
54110	599	Other Charges	05/07/2026	1010284988	Shred-It	83.50
54110	599	Other Charges	05/14/2026	1010285019	English Mountain Spring Water	15.00
54110	599	Other Charges	05/14/2026	1010285028	HomeTrust Bank	2,138.03
54110	599	Other Charges	05/21/2026	1010285112	English Mountain Spring Water	22.50
54110	599	Other Charges	05/21/2026	1010285122	Hamblen County Clerk	6.50
54110	599	Other Charges	05/21/2026	1010285141	Southern Care Veterinary Hospital	290.00
54110	599	Other Charges	05/28/2026	1010285155	Cherokee Boat Dock LLC	110.00
54110	716	Law Enforcement Equipment	05/07/2026	1010284970	Gulf States Distributors	1,110.00
54110	716	Law Enforcement Equipment	05/14/2026	1010285021	Galls, LLC	990.00
54110	716	Law Enforcement Equipment	05/14/2026	1010285023	Gulf States Distributors	248.00
54110	716	Law Enforcement Equipment	05/14/2026	1010285028	HomeTrust Bank	2,995.64
54110	716	Law Enforcement Equipment	05/14/2026	1010285041	Precision Delta Corporation	3,850.00
54110	716	Law Enforcement Equipment	05/21/2026	1010285107	Craig's Firearm Supply	970.20
54110	716	Law Enforcement Equipment	05/21/2026	1010285120	Gulf States Distributors	165.00
54110	716	Law Enforcement Equipment	05/22/2026	1010285151	Amazon Capital Services, Inc.	444.75
54110	716	Law Enforcement Equipment	05/28/2026	1010285158	Galls, LLC	240.00
54110		Sheriff's Department		Check Count:	37	Total: 53,415.52
54210	317	Data Processing Services	05/21/2026	1010285119	GovConnection, Inc.	108.11
54210	334	Maintenance Agreements	05/14/2026	1010285017	Eagle Advantage Solutions, Inc.	194.79
54210	335	Maintenance And Repair Service - Buildings	05/07/2026	1010284976	Interstate Mechanical Service, LLC	2,028.38
54210	335	Maintenance And Repair Service - Buildings	05/07/2026	1010284978	Lowe's	415.89
54210	335	Maintenance And Repair Service - Buildings	05/21/2026	1010285109	Darien DeMayo	123.00
54210	335	Maintenance And Repair Service - Buildings	05/21/2026	1010285113	Eskola, LLC	439.38
54210	335	Maintenance And Repair Service - Buildings	05/22/2026	1010285151	Amazon Capital Services, Inc.	165.24
54210	336	Maintenance And Repair Services - Equipment	05/07/2026	1010284965	Food Equipment Services Co	187.50

COMMISSION APPROVAL LISTING

ACCT	OB	Name	Date	Check Nbr	Description	Amount Paid
Fund: General Fund #(101)						
54210	336	Maintenance And Repair Services - Equipment	05/14/2026	1010285020	Food Equipment Services Co	502.50
54210	340	Medical And Dental Services	05/07/2026	1010284963	East Tennessee Pathology PPLC	104.58
54210	340	Medical And Dental Services	05/14/2026	1010285005	American Esoteric Laboratories	41.50
54210	340	Medical And Dental Services	05/14/2026	1010285018	East Tennessee Pathology PPLC	45.11
54210	340	Medical And Dental Services	05/14/2026	1010285036	Morristown-Hamblen Hospital	5,457.27
54210	340	Medical And Dental Services	05/14/2026	1010285051	University Health System Inc	60.00
54210	340	Medical And Dental Services	05/14/2026	1010285052	University Radiology	521.00
54210	340	Medical And Dental Services	05/21/2026	1010285096	American Esoteric Laboratories	1,404.20
54210	340	Medical And Dental Services	05/21/2026	1010285110	East Tennessee Pathology PPLC	290.62
54210	340	Medical And Dental Services	05/21/2026	1010285116	Fort Sanders Perinatal Center	350.00
54210	340	Medical And Dental Services	05/21/2026	1010285130	Mobile Images Acquisition LLC	1,575.00
54210	340	Medical And Dental Services	05/21/2026	1010285132	Morristown-Hamblen Hospital	10,164.82
54210	340	Medical And Dental Services	05/21/2026	1010285140	Southeastern Emergency Physicians	1,074.75
54210	340	Medical And Dental Services	05/21/2026	1010285142	Southern Health Partners	62,812.66
54210	340	Medical And Dental Services	05/21/2026	1010285148	Vista Radiology	1,054.90
54210	351	Rentals	05/14/2026	1010285047	T.E.G. Enterprises, Inc	150.00
54210	410	Custodial Supplies	05/07/2026	1010284964	EVI Industries Inc	1,132.60
54210	410	Custodial Supplies	05/07/2026	1010285000	Wet Washing Equipment Technologies	5,412.45
54210	422	Food Supplies	05/07/2026	1010284993	Trinity Services Group, Inc.	24,690.53
54210	451	Uniforms	05/21/2026	1010285147	TruBlu Tactical Police Supply	2,569.65
54210	451	Uniforms	05/07/2026	9101001413	Charles J Ayers	100.00
54210	524	In Service/Staff Development	05/07/2026	1010284960	Correctional Counseling, Inc	703.21
54210	524	In Service/Staff Development	05/21/2026	1010285145	TN Corrections Institute	300.00
54210	599	Other Charges	05/14/2026	1010285043	SEI Waste, LLC	1,826.43
54210	599	Other Charges	05/14/2026	1010285044	Shred-It	30.00
54210	599	Other Charges	05/21/2026	1010285103	Canon Solutions America, Inc	91.97
54210	716	Law Enforcement Equipment	05/07/2026	1010284981	Metro Communications	196.18

COMMISSION APPROVAL LISTING

ACCT	OB	Name	Date	Check Nbr	Description	Amount Paid
Fund: General Fund #(101)						
54210	716	Law Enforcement Equipment	05/14/2026	1010285009	Bob Barker Company, Inc	296.81
54210	716	Law Enforcement Equipment	05/14/2026	1010285021	Galls, LLC	3,794.85
54210	716	Law Enforcement Equipment	05/14/2026	1010285031	Med Express, Inc	885.00
54210	716	Law Enforcement Equipment	05/22/2026	1010285151	Amazon Capital Services, Inc.	599.10
54210	716	Law Enforcement Equipment	05/28/2026	1010285152	Cartwright Communication Inc	4,430.68
54210	Jail			Check Count:	39	Total: 136,330.66
54250	307	Communication	05/21/2026	1010285098	AT&T Mobility	122.88
54250	317	Data Processing Services	05/21/2026	1010285119	GovConnection, Inc.	57.60
54250	338	Maintenance And Repair Services - Vehicles	05/14/2026	1010285045	Spotless Brands Intermediate I, LLC	30.00
54250	399	Other Contracted Services	05/07/2026	1010284974	Helen Ross McNabb Center	200,000.00
54250	399	Other Contracted Services	05/14/2026	1010285046	Stepping Out Ministries	80.00
54250	425	Gasoline	05/21/2026	1010285117	Fuelman	339.16
54250	Work Release Program			Check Count:	6	Total: 200,629.64
54410	307	Communication	05/21/2026	1010285098	AT&T Mobility	77.24
54410	317	Data Processing Services	05/21/2026	1010285119	GovConnection, Inc.	46.08
54410	338	Maintenance And Repair Services - Vehicles	05/14/2026	1010285045	Spotless Brands Intermediate I, LLC	15.00
54410	425	Gasoline	05/21/2026	1010285117	Fuelman	289.88
54410	599	Other Charges	05/14/2026	1010285028	HomeTrust Bank	904.94
54410	Civil Defense			Check Count:	5	Total: 1,333.14
54490	316	Contributions	05/05/2026	1010284951	Morristown Hamblen Emergency Medical Service	73,892.00
54490	Other Emergency Management			Check Count:	1	Total: 73,892.00
54610	307	Communication	05/21/2026	1010285098	AT&T Mobility	371.14
54610	312	Contracts With Private Agencies	05/07/2026	1010284994	Tri-Star Removal and Transportation LLC	750.00
54610	312	Contracts With Private Agencies	05/14/2026	1010285030	Knox County Medical Examiner	6,225.00

COMMISSION APPROVAL LISTING

ACCT	OB	Name	Date	Check Nbr	Description	Amount Paid
Fund: General Fund #(101)						
54610	317	Data Processing Services	05/21/2026	1010285119	GovConnection, Inc.	115.20
54610	399	Other Contracted Services	05/21/2026	1010285095	Daniel Allison	113.30
54610	399	Other Contracted Services	05/21/2026	1010285100	Travis Barner	396.55
54610	399	Other Contracted Services	05/21/2026	1010285105	Kevin Carroll	772.50
54610	399	Other Contracted Services	05/21/2026	1010285123	Jeffrey E. Holt	623.15
54610	399	Other Contracted Services	05/21/2026	1010285124	Amanda Beth Hopkins	309.00
54610	399	Other Contracted Services	05/21/2026	1010285144	Claude Thompson JR	731.30
54610	399	Other Contracted Services	05/07/2026	9101001417	Tom C Thompson MD	2,500.00
54610		Medical Examiner			Check Count: 11	Total: 12,907.14
54710	307	Communication	05/21/2026	1010285098	AT&T Mobility	103.67
54710	355	Travel	05/21/2026	9101001500	Penny Knight	552.45
54710	399	Other Contracted Services	05/14/2026	1010285002	Allard Consulting	3,660.00
54710	399	Other Contracted Services	05/14/2026	1010285027	Health Connect America, Inc	4,770.00
54710	463	Testing	05/21/2026	1010285125	Intrinsic Interventions Inc.	6,289.50
54710		Drug Court Expansion - Public Safety Grant			Check Count: 5	Total: 15,375.62
55110	307	Communication	05/21/2026	1010285097	AT&T	269.17
55110	355	Travel	05/07/2026	9101001412	Jennifer A Antrican	76.13
55110	355	Travel	05/07/2026	9101001414	Janice D Messer	5.80
55110	355	Travel	05/07/2026	9101001415	Kim Smith	102.95
55110	355	Travel	05/07/2026	9101001416	Shamron D Stambaugh	36.25
55110	435	Office Supplies	05/21/2026	1010285114	Evans Office Supply Co	187.00
55110	452	Utilities	05/28/2026	1010285162	Morristown Utilities	1,319.00
55110	599	Other Charges	05/14/2026	1010285028	HomeTrust Bank	281.44
55110		Local Health Center			Check Count: 8	Total: 2,277.74
55120	307	Communication	05/21/2026	1010285098	AT&T Mobility	154.48

COMMISSION APPROVAL LISTING

ACCT	OB	Name	Date	Check Nbr	Description	Amount Paid
Fund: General Fund #(101)						
55120	312	Contracts With Private Agencies	05/07/2026	1010284983	Morristown-Hamblen Humane Soc	25,000.00
55120	317	Data Processing Services	05/21/2026	1010285119	GovConnection, Inc.	23.04
55120	338	Maintenance And Repair Services - Vehicles	05/14/2026	1010285045	Spotless Brands Intermediate I, LLC	30.00
55120	425	Gasoline	05/21/2026	1010285117	Fuelman	603.32
55120	450	Tires And Tubes	05/21/2026	1010285135	Porter's Tire Store Inc.	880.00
55120		Rabies And Animal Control			Check Count: 6	Total: 26,690.84
55590	316	Contributions	05/07/2026	1010284973	Helen Ross McNabb Center	85.00
55590		Other Local Welfare Services			Check Count: 1	Total: 85.00
55710	309	Contracts With Government Agencies	05/21/2026	1010285126	Keep M'town Hamblen Beautiful	7,140.00
55710		Sanitation Management			Check Count: 1	Total: 7,140.00
56700	307	Communication	05/07/2026	1010284985	MUS Fibernet	82.26
56700	307	Communication	05/21/2026	1010285098	AT&T Mobility	84.46
56700	317	Data Processing Services	05/21/2026	1010285119	GovConnection, Inc.	11.52
56700	336	Maintenance And Repair Services - Equipment	05/07/2026	1010284961	Curt's Ace Hardware	93.53
56700	336	Maintenance And Repair Services - Equipment	05/07/2026	1010284978	Lowe's	433.89
56700	336	Maintenance And Repair Services - Equipment	05/21/2026	1010285108	Curt's Ace Hardware	150.96
56700	336	Maintenance And Repair Services - Equipment	05/21/2026	1010285127	Lane Sales Power Equipment	212.19
56700	410	Custodial Supplies	05/14/2026	1010285043	SEI Waste, LLC	500.46
56700	410	Custodial Supplies	05/21/2026	1010285101	Big M Janitorial	202.91
56700	415	Electricity	05/07/2026	1010284982	Morristown Utilities	229.00
56700	415	Electricity	05/14/2026	1010285006	Appalachian Electric Co-Op	59.14
56700	415	Electricity	05/14/2026	1010285035	Morristown Utilities	2,201.00
56700	425	Gasoline	05/21/2026	1010285149	Voyager Fleet Systems Inc	500.52
56700	435	Office Supplies	05/14/2026	1010285028	HomeTrust Bank	93.66
56700	451	Uniforms	05/07/2026	1010284954	BK Graphics LLC	213.64

COMMISSION APPROVAL LISTING

ACCT	OB	Name	Date	Check Nbr	Description	Amount Paid
Fund: General Fund #(101)						
56700	454	Water And Sewer	05/07/2026	1010284982	Morristown Utilities	3,119.00
56700	499	Other Supplies And Materials	05/07/2026	1010284962	Darien DeMayo	300.00
56700	499	Other Supplies And Materials	05/21/2026	1010285136	Relief Septic Repair & Service Inc.	300.00
56700	509	Refunds	05/07/2026	1010284977	Vivian Lopez	100.00
56700	599	Other Charges	05/14/2026	1010285019	English Mountain Spring Water	38.50
56700	599	Other Charges	05/14/2026	1010285042	Dylan Samples	240.00
56700	599	Other Charges	05/21/2026	1010285112	English Mountain Spring Water	16.00
56700	791	Other Construction	05/14/2026	1010285004	Richard S. Allen	50,800.00
56700	791	Other Construction	05/14/2026	1010285034	Miller's Electric LLC	250.00
56700		Parks And Fair Boards		Check Count:	23	Total: 60,232.64
57100	140	Salary Supplements	05/07/2026	1010284997	University Of TN Extension	41,000.72
57100		Agricultural Extension Service		Check Count:	1	Total: 41,000.72
57800	321	Engineering Services	05/14/2026	1010285026	T Clint Harrison	6,685.00
57800	399	Other Contracted Services	05/07/2026	1010284969	LLC GEO Services	2,225.60
57800	399	Other Contracted Services	05/07/2026	1010284995	Robert Tucker	69.99
57800	429	Instructional Supplies And Materials	05/14/2026	1010285028	HomeTrust Bank	929.75
57800		Storm Water Management		Check Count:	4	Total: 9,910.34
58110	399	Other Contracted Services	05/07/2026	1010284980	Selena Martin	150.00
58110		Tourism		Check Count:	1	Total: 150.00
58300	317	Data Processing Services	05/21/2026	1010285119	GovConnection, Inc.	11.52
58300		Veterans' Services		Check Count:	1	Total: 11.52
58600	210	Unemployment Compensation	05/07/2026	1010284991	TN Dept Of Labor Workforce Development	325.00
58600	299	Other Fringe Benefits	05/21/2026	1010285121	Hamblen Co Dept Of Education	137.50

COMMISSION APPROVAL LISTING

ACCT	OB	Name	Date	Check Nbr	Description	Amount Paid
Fund: General Fund #(101)						
58600		Employee Benefits			Check Count: 2	Total: 462.50
58900	399	Other Contracted Services	05/07/2026	1010284955	City of Morristown	121.47
58900		Miscellaneous			Check Count: 1	Total: 121.47
91110	799	Other Capital Outlay	05/07/2026	1010284984	Morristown-Hamblen Library	26,447.09
91110		General Administration Projects			Check Count: 1	Total: 26,447.09
91140	707	Building Improvements	05/07/2026	1010284956	Construction Partners, LLC	5,889.85
91140	707	Building Improvements	05/07/2026	1010284957	Construction Partners, LLC	3,725.95
91140	707	Building Improvements	05/07/2026	1010284958	Construction Partners, LLC	111,907.15
91140	707	Building Improvements	05/07/2026	1010284959	Construction Partners, LLC	70,793.05
91140	791	Other Construction	05/21/2026	1010285133	Murrell Burglar Alarm Co Inc	43,155.03
91140		Public Health And Welfare Projects			Check Count: 5	Total: 235,471.03
General Fund #(101) Total:						1,126,844.08

COMMISSION APPROVAL LISTING

ACCT	OB	Name	Date	Check Nbr	Description	Amount Paid
Fund: Drug Control Fund #(122)						
54150	351	Rentals	05/14/2026	1220003088	T.E.G. Enterprises, Inc	65.00
54150	401	Animal Food And Supplies	05/14/2026	1220003086	HomeTrust Bank	75.98
54150	415	Electricity	05/14/2026	1220003087	MUS Fibernet	102.37
54150	431	Law Enforcement Supplies	05/22/2026	1220003089	Amazon Capital Services, Inc.	145.89
54150		Drug Enforcement		Check Count:	4	Total: 389.24
Drug Control Fund #(122) Total:						389.24

COMMISSION APPROVAL LISTING

ACCT	OB	Name	Date	Check Nbr	Description	Amount Paid
Fund: Drug Use Abatement Fund						
55130	316	Contributions	05/05/2026	1280000028	Morristown Hamblen Emergency Medical Service	133,608.00
55130		Ambulance/Emergency Medical Se			Check Count: 1	Total: 133,608.00
Drug Use Abatement Fund Total:						133,608.00

COMMISSION APPROVAL LISTING

ACCT	OB	Name	Date	Check Nbr	Description	Amount Paid
Fund: Special Debt Service						
82210	603	Interest On Bonds	05/21/2026	1540000017	Hometrtrust Bank	13,622.31
82210		General Government			Check Count: 1	Total: 13,622.31
82310	399	Other Contracted Services	05/07/2026	9154000002	Arbitrage Compliance Specialists Inc	1,300.00
82310		General Government			Check Count: 1	Total: 1,300.00
Special Debt Service Total:						14,922.31

COMMISSION APPROVAL LISTING

ACCT	OB	Name	Date	Check Nbr	Description	Amount Paid
Fund: General Capital Projects Fund #(171)						
91140	791	Other Construction	05/07/2026	1710001811	Clark Construction & Remodeling LLC	17,700.00
91140		Public Health And Welfare Projects			Check Count: 1	Total: 17,700.00
General Capital Projects Fund #(171) Total:						17,700.00

COMMISSION APPROVAL LISTING

ACCT	OB	Name	Date	Check Nbr	Description	Amount Paid
Fund: Highway Capital Projects Fund #(176)						
91200	404	Asphalt - Hot Mix	05/21/2026	1760001155	Blalock & Sons Inc	8,573.27
91200		Highway And Street Capital Projects			Check Count: 1	Total: 8,573.27
Highway Capital Projects Fund #(176) Total:						8,573.27

COMMISSION APPROVAL LISTING

ACCT	OB	Name	Date	Check Nbr	Description	Amount Paid
Fund: Other Capital Projects Fund/Fu						
91170	791	Other Construction	05/21/2026	1780000017	Alpha Talbott Utility District	425,119.00
91170	791	Other Construction	05/21/2026	1780000018	Witt Utility District	303,326.64
91170		Public Utility Projects			Check Count: 2	Total: 728,445.64
Other Capital Projects Fund/Fu Total:						728,445.64

COMMISSION APPROVAL LISTING

ACCT	OB	Name	Date	Check Nbr	Description	Amount Paid
Fund: Other Capital Projects Fund # (189)						
91130	711	Furniture And Fixtures	05/07/2026	1890000243	CMS Communications	3,990.00
91130	711	Furniture And Fixtures	05/07/2026	1890000244	Salsbury Industries, Inc.	2,703.95
91130	711	Furniture And Fixtures	05/21/2026	1890000245	Metro Communications	1,958.56
91130	711	Furniture And Fixtures	05/21/2026	1890000246	Special-T, LLC	1,246.31
91130	711	Furniture And Fixtures	05/22/2026	1890000247	Amazon Capital Services, Inc.	157.89
91130		Public Safety Projects			Check Count: 5	Total: 10,056.71
Other Capital Projects Fund # (189) Total:						10,056.71

COMMISSION APPROVAL LISTING

ACCT	OB	Name	Date	Check Nbr	Description	Amount Paid
Fund: Employee Insurance - General Fund#(264)						
58600	312	Contracts With Private Agencies	05/07/2026	2640002055	LLC STP	1,850.00
58600	312	Contracts With Private Agencies	05/14/2026	2640002056	Murrell Burglar Alarm Co Inc	38.00
58600	312	Contracts With Private Agencies	05/21/2026	2640002057	Atmos Energy	52.76
58600	312	Contracts With Private Agencies	05/21/2026	2640002058	Carehere LLC	40,598.19
58600	312	Contracts With Private Agencies	05/28/2026	2640002059	Morristown Utilities	266.00
58600		Employee Benefits			Check Count: 5	Total: 42,804.95
Employee Insurance - General Fund#(264) Total:						42,804.95

COMMISSION APPROVAL LISTING

ACCT	OB	Name	Date	Check Nbr	Description	Amount Paid
Fund: Solid Waste/Sanitation Fund #(116)						
55710	307	Communication	05/21/2026	1160025957	AT&T	73.90
55710	307	Communication	05/21/2026	1160025958	AT&T Mobility	62.71
55710	312	Contracts With Private Agencies	05/14/2026	1160025951	Cintas Corp., Loc. 207	1,028.61
55710	336	Maintenance And Repair Services - Equipment	05/14/2026	1160025953	Mid-State Equip Co,Inc	1,230.82
55710	336	Maintenance And Repair Services - Equipment	05/14/2026	1160025955	Southern Fluidpower, Inc.	465.94
55710	336	Maintenance And Repair Services - Equipment	05/14/2026	1160025956	Worldwide Equipment, Inc.	1,680.03
55710	336	Maintenance And Repair Services - Equipment	05/21/2026	1160025964	NAPA Auto Parts Of Morristown	1,790.65
55710	359	Disposal Fees	05/21/2026	1160025961	Hamblen County-Morristown Solid Waste	115,589.80
55710	412	Diesel Fuel	05/21/2026	1160025959	Fuelman	19,695.92
55710	415	Electricity	05/21/2026	1160025962	Holston Electric Cooperative	402.22
55710	425	Gasoline	05/21/2026	1160025959	Fuelman	341.63
55710	435	Office Supplies	05/07/2026	1160025948	Citizen Tribune	135.66
55710	435	Office Supplies	05/22/2026	1160025966	Amazon Capital Services, Inc.	17.16
55710	450	Tires And Tubes	05/21/2026	1160025960	Goforth Tire & Auto, Inc	10,062.30
55710	451	Uniforms	05/14/2026	1160025951	Cintas Corp., Loc. 207	77.12
55710	451	Uniforms	05/21/2026	1160025965	Unifirst Corp	564.83
55710	454	Water And Sewer	05/21/2026	1160025963	Morristown Utilities	62.00
55710	499	Other Supplies And Materials	05/07/2026	1160025949	UniFirst First Aid Corp	110.48
55710	499	Other Supplies And Materials	05/22/2026	1160025966	Amazon Capital Services, Inc.	564.77
55710		Sanitation Management		Check Count: 16	Total:	153,956.55
Solid Waste/Sanitation Fund #(116) Total:						153,956.55

COMMISSION APPROVAL LISTING

ACCT	OB	Name	Date	Check Nbr	Description	Amount Paid
Fund: Highway/Public Works Fund (#131)						
61000	307	Communication	05/21/2026	1313046036	AT&T	73.90
61000	307	Communication	05/21/2026	1313046037	AT&T Mobility	62.71
61000	317	Data Processing Services	05/21/2026	1313046040	GovConnection, Inc.	81.37
61000	415	Electricity	05/21/2026	1313046041	Holston Electric Cooperative	402.23
61000	415	Electricity	05/28/2026	1313046048	Morristown Utilities	2,077.00
61000	435	Office Supplies	05/07/2026	1313046022	Citizen Tribune	212.90
61000	435	Office Supplies	05/21/2026	1313046038	Citizen Tribune	212.90
61000	435	Office Supplies	05/22/2026	1313046047	Amazon Capital Services, Inc.	54.60
61000	454	Water and Sewer	05/21/2026	1313046043	Morristown Utilities	62.00
61000	599	Other Charges	05/07/2026	1313046024	Lowe's	669.42
61000	599	Other Charges	05/14/2026	1313046026	Cintas Corp., Loc. 207	78.76
61000	599	Other Charges	05/14/2026	1313046031	Spotless Brands Intermediate I, LLC	30.00
61000		Administration			Check Count: 12	Total: 4,017.79
62000	312	Contracts With Private Agencies	05/07/2026	1313046025	Witt Utility District	771.29
62000	426	General Construction Materials	05/14/2026	1313046029	Smoky Mountain Farmers Co-Op	402.13
62000	443	Road Signs	05/22/2026	1313046047	Amazon Capital Services, Inc.	145.99
62000	451	Uniforms	05/14/2026	1313046026	Cintas Corp., Loc. 207	100.12
62000	451	Uniforms	05/21/2026	1313046046	Unifirst Corp	574.60
62000		Highway And Bridge Maintenance			Check Count: 5	Total: 1,994.13
63100	412	Diesel Fuel	05/21/2026	1313046039	Fuelman	4,161.49
63100	412	Diesel Fuel	05/21/2026	1313046045	Pioneer Petroleum	3,341.53
63100	416	Equipment Parts - Heavy	05/14/2026	1313046029	Smoky Mountain Farmers Co-Op	174.98
63100	416	Equipment Parts - Heavy	05/14/2026	1313046030	Southern Fluidpower, Inc.	124.18
63100	416	Equipment Parts - Heavy	05/14/2026	1313046032	Stowers Machinery Corporation	2,343.44
63100	416	Equipment Parts - Heavy	05/14/2026	1313046033	The Lilly Company	416.31
63100	416	Equipment Parts - Heavy	05/14/2026	1313046035	Worldwide Equipment, Inc.	494.55

COMMISSION APPROVAL LISTING

ACCT	OB	Name	Date	Check Nbr	Description	Amount Paid
Fund: Highway/Public Works Fund (#131)						
63100	416	Equipment Parts - Heavy	05/21/2026	1313046042	Moore's Tractor and Trailer Repair Inc	2,036.37
63100	416	Equipment Parts - Heavy	05/21/2026	1313046044	NAPA Auto Parts Of Morristown	3,927.21
63100	425	Gasoline	05/21/2026	1313046039	Fuelman	2,992.38
63100	433	Lubricants	05/14/2026	1313046034	Universal Total Lubricants, Inc.	3,422.56
63100	499	Other Supplies And Materials	05/07/2026	1313046023	Lane Sales Power Equipment	136.30
63100	499	Other Supplies And Materials	05/22/2026	1313046047	Amazon Capital Services, Inc.	62.99
63100		Operation And Maintenance Of Equipment			Check Count: 12	Total: 23,634.29
Highway/Public Works Fund (#131) Total:						29,646.21

Resolution 26 - 12

A RESOLUTION AUTHORIZING THE HAMBLLEN COUNTY SHERIFF'S OFFICE TO APPLY FOR THE STATEWIDE SCHOOL RESOURCE OFFICER (SRO) PROGRAM GRANT IN THE AMOUNT OF \$1,350,000.00

WHEREAS, the SRO grant will support:

- 1) A total of 18 Hamblen County deputies being placed in each of the 18 Hamblen County public schools.
- 2) The safety of students and staff throughout the school year, during summer school sessions, and at school related after-hour events.
- 3) The building of positive relationships between students and members of law enforcement.

WHEREAS, that Hamblen County Commission desires to take advantage of this reimbursable grant where the County will incur the costs and receive reimbursements upon request from the State. The SRO Grant is a non-matching grant.

NOW, THEREFORE, BE IT RESOLVED that Hamblen County Commission does hereby authorize the Hamblen County Sheriff's Office to prepare an application for the Statewide School Resource Officer (SRO) Program Grant in the amount of \$1,350,000.00.

Duly passed and approved this ____ day of June 2026.

APPROVED: _____
Bobby Haun, Chairman, HCLB

ATTESTED: _____
Peggy Henderson, County Clerk

RFP Bank Comparisons

All banks are equal as far as answering all RFP questions

Contract Cancellation

Remote Deposit Scanners

Electronic banking etc

Interest Rate base on T Bills, Fed Funds rate

	Non-Bearing Interest Amount		Interest Rate
HomeTrust	\$2,000,000.00 Fixed Amount	No Additional Fees Wires/Stop Payments	3.65%
First Horizon	\$4,700,000.00 Fixed Amount	Additional Fees Wires \$15/\$15 Stop Payments \$37	3.50%
	Variable Amount Based on ECR/Bank Balance		

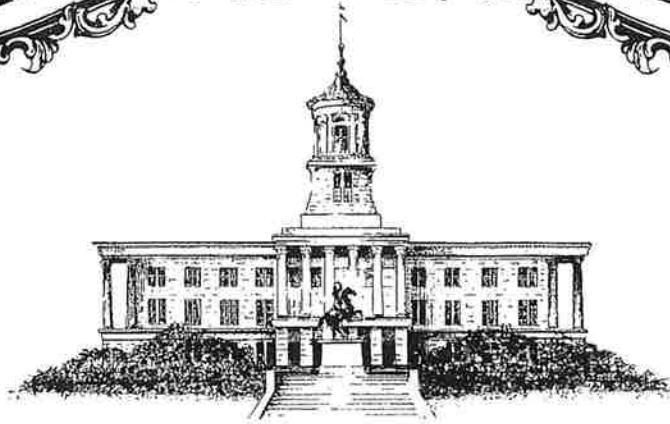
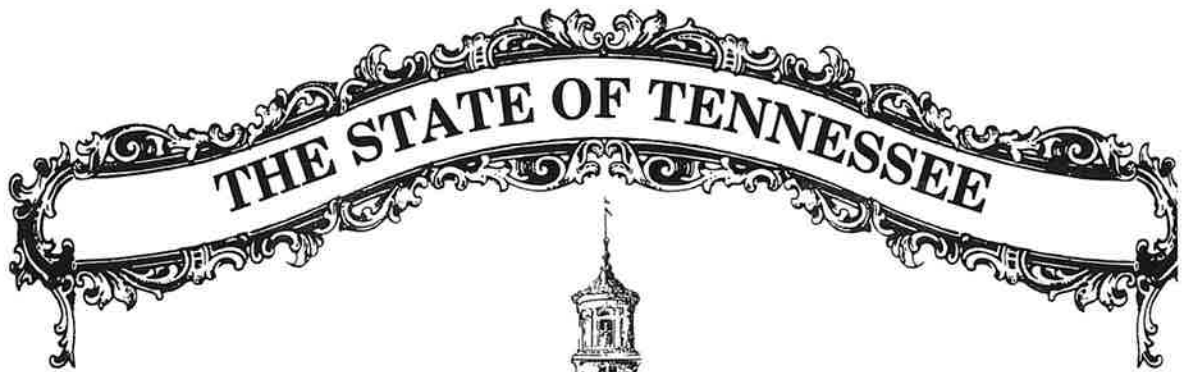

To all to whom these Presents shall come, Greeting:

*I, Tre Hargett, Secretary of State of the State of Tennessee,
do hereby certify that the annexed is a true copy of*

Private Chapter No. 57

House Bill No. 2640

Senate Bill No. 2705

114th General Assembly



*the original of which is now on file and a matter
of record in this office. In Testimony Whereof,
I have hereunto subscribed my official signature
and by order of the Governor affixed the Great
Seal of Tennessee at the Department
in the City of Nashville,
this 8th day of June, A.D. 2026.*

Tre Hargett, Secretary of State



State of Tennessee

PRIVATE CHAPTER NO. 57

HOUSE BILL NO. 2640

By Representative Eldridge

Substituted for: Senate Bill No. 2705

By Senator Southerland

AN ACT to repeal Chapter 313 of the Private Acts of 1949; as amended by Chapter 679 of the Private Acts of 1949; Chapter 398 of the Private Acts of 1951; Chapter 219 of the Private Acts of 1953; Chapter 170 of the Private Acts of 1953; Chapter 111 of the Private Acts of 1963; Chapter 19 of the Private Acts of 1963; Chapter 366 of the Private Acts of 1968; Chapter 74 of the Private Acts of 1969; Chapter 274 of the Private Acts of 1974; Chapter 138 of the Private Acts of 1975; Chapter 306 of the Private Acts of 1982; Chapter 143 of the Private Acts of 1988; Chapter 1 of the Private Acts of 1991; Chapter 161 of the Private Acts of 1996; Chapter 29 of the Private Acts of 2003; Chapter 72 of the Private Acts of 2004 and Chapter 1 of the Private Acts of 2023, and any other acts amendatory thereto, relative to the Hamblen County Highway Department.

BE IT ENACTED BY THE GENERAL ASSEMBLY OF THE STATE OF TENNESSEE:

SECTION 1. Chapter 313 of the Private Acts of 1949, as amended by Chapter 679 of the Private Acts of 1949, Chapter 398 of the Private Acts of 1951, Chapter 170 of the Private Acts of 1953, Chapter 219 of the Private Acts of 1953, Chapter 19 of the Private Acts of 1963, Chapter 111 of the Private Acts of 1963, Chapter 366 of the Private Acts of 1968, Chapter 74 of the Private Acts of 1969, Chapter 274 of the Private Acts of 1974, Chapter 138 of the Private Acts of 1975, Chapter 306 of the Private Acts of 1982, Chapter 143 of the Private Acts of 1988, Chapter 1 of the Private Acts of 1991, Chapter 161 of the Private Acts of 1996, Chapter 29 of the Private Acts of 2003, Chapter 72 of the Private Acts of 2004, Chapter 1 of the Private Acts of 2023, and any other acts amendatory thereto, are repealed effective August 31, 2028.

SECTION 2. The Hamblen County, Tennessee, Road Commission is abolished effective August 31, 2028. Should a vacancy on the Road Commission occur prior to August 31, 2028, the vacancy shall not be filled for the remainder of the unexpired term. Nothing in this Act shall be construed as having the effect of removing any incumbent from office or abridging the term of any official prior to the end of the term for which they were elected. The amount of compensation paid to members of the Road Commission shall be determined by the legislative body of Hamblen County and is payable out of the county highway fund. The members of the Road Commission shall elect one (1) of their members to serve as chairman. A majority of the Road Commission shall constitute a quorum for the conduct of business.

SECTION 3. For the purpose of providing an efficient system of roads, highways, and bridges and the building, construction, reconstruction, maintenance and repair of roads, highways, and bridges in Hamblen County, Tennessee, the office of Road Superintendent for said County is hereby created. At the regular August election in 2028, and every four (4) years thereafter, a Road Superintendent shall be elected by popular vote by the qualified voters of Hamblen County to serve a term of four (4) years. The Road Superintendent shall assume office on September 1 following the election and shall continue to hold office until a successor is elected and qualified. The qualifications and salary for the Road Superintendent shall be as prescribed by the County Uniform Highway Law, Tennessee Code Annotated, Title 54, Chapter 7.

SECTION 4.

(a) The Road Superintendent shall have all the powers and duties set forth in the County Uniform Highway Law, Tennessee Code Annotated, Title 54, Chapter 7.

(b) In addition to the duties prescribed in subsection (a), the Road Superintendent, at the Superintendent's discretion, may oversee the Hamblen County

Sanitation Department. Any supplemental salary arising out of and relating to such oversight of the Hamblen County Sanitation Department shall be subject to the approval of the legislative body of Hamblen County.

SECTION 5. Purchasing for the highway department shall be governed by the County Uniform Highway Law, Tennessee Code Annotated, Title 54, Chapter 7, and any other purchasing laws applicable to Hamblen County.

SECTION 6. All laws or parts of laws in conflict with this act are hereby expressly repealed. If any provision of this act or the application thereof to any person or circumstance is held invalid, such invalidity shall not affect other provisions or applications of the act which can be given without the invalid provision or application, and to that end, the provisions of this act are declared to be severable.

SECTION 7. This act shall have no effect unless it is approved by a two-thirds (2/3) vote of the legislative body of Hamblen County. Its approval or nonapproval shall be proclaimed by the presiding officer of the county legislative body and certified to the Secretary of State.

SECTION 8. For the purpose of approving or rejecting the provisions of this act, it shall be effective upon becoming a law, the public welfare requiring it. For all other purposes, it shall become effective upon being approved as provided in Section 7.

HOUSE BILL NO. 2640

PASSED: April 15, 2026



CAMERON SEXTON, SPEAKER
HOUSE OF REPRESENTATIVES



RANDY MCNALLY
SPEAKER OF THE SENATE

APPROVED this 21st day of May 2026



BILL LEE, GOVERNOR

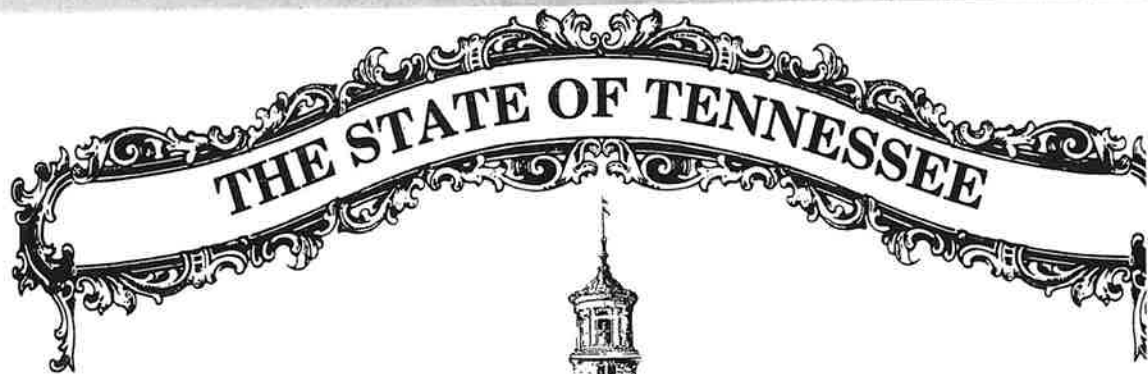

To all to whom these Presents shall come, Greeting:

*I, Tre Hargett, Secretary of State of the State of Tennessee,
do hereby certify that the annexed is a true copy of*

Private Chapter No. 58

House Bill No. 2642

Senate Bill No. 2703

114th General Assembly



*the original of which is now on file and a matter
of record in this office. In Testimony Whereof
I have hereunto subscribed my official signatu
and by order of the Governor affixed the Great
Seal of Tennessee at the Department
in the City of Nashville,
this 8th day of June, A.D. 2026.*

Tre Hargett, Secretary of State



State of Tennessee

PRIVATE CHAPTER NO. 58

HOUSE BILL NO. 2642

By Representative Eldridge

Substituted for: Senate Bill No. 2703

By Senator Southerland

AN ACT to amend Chapter 677 of the Private Acts of 1949; as amended by Chapter 434 of the Private Acts of 1968; and any other acts amendatory thereto, relative to the office of county attorney for Hamblen County.

BE IT ENACTED BY THE GENERAL ASSEMBLY OF THE STATE OF TENNESSEE:

SECTION 1. Chapter 677 of the Private Acts of 1949, as amended by Chapter 434 of the Private Acts of 1968, and any other acts amendatory thereto, is amended by deleting SECTION 1 and substituting:

SECTION 1. That there is hereby created the office of County Attorney for Hamblen County. The County Attorney shall be elected by the Hamblen County Commission annually at the September meeting designated for the election of County Attorney.

SECTION 2. Chapter 677 of the Private Acts of 1949, and any other acts amendatory thereto, is amended by deleting SECTION 2 and substituting:

SECTION 2. [Deleted by 2026 amendment]

SECTION 3. Chapter 677 of the Private Acts of 1949, as amended by Chapter 434 of the Private Acts of 1968, and any other acts amendatory thereto, is amended by deleting SECTION 3 and substituting:

SECTION 3. The County Attorney for services, shall be paid an annual retainer fee of Twelve Hundred Dollars (\$1200), payable in equal monthly installments out of the general funds of the County, by warrant of the County Judge or Chairman upon the trustee. For legal services performed on behalf of the County, the County Attorney shall be entitled to receive additional reasonable compensation and reimbursement for actual expenses incurred. All compensation and reimbursement are subject to review by the County Legislative Body through the Consent Calendar. Claims for expenses shall be itemized and certified by the County Attorney, upon standard County financial policies, shall be paid in the same manner as the retainer and other fees.

SECTION 4. This act shall have no effect unless it is approved by a two-thirds (2/3) vote of the legislative body of Hamblen County. Its approval or nonapproval shall be proclaimed by the presiding officer of the legislative body and certified to the secretary of state.

SECTION 5. For the purpose of approving or rejecting the provisions of this act, it shall be effective upon becoming a law, the public welfare requiring it. For all other purposes, it shall become effective as provided in Section 4.

HOUSE BILL NO. 2642

PASSED: April 15, 2026



CAMERON SEXTON, SPEAKER
HOUSE OF REPRESENTATIVES



RANDY MCNALLY
SPEAKER OF THE SENATE

APPROVED this 21st day of May 2026



BILL LEE, GOVERNOR

MetTel Communications Solution

Prepared For
Hamblen County, TN

Presented On
May 19, 2026

Presented By
MetTel



Dear Hamblen County, TN,

Thank you for the opportunity to propose a MetTel solution for your business communications needs. At MetTel, we strive to achieve the best value for our customers by providing a comprehensive suite of telecommunications solutions. From traditional voice services to software-defined networks and mobility solutions, MetTel is the preferred solution provider of enterprise and government customers.

We are committed to delivering immediate and sustainable cost and operational efficiencies to our customers:

- Significant hard and soft dollar savings
- Cloud-based communications management platform with detailed invoicing, reporting and help desk functionality
- Service availability for all communications solutions across the United States, Canada, and Puerto Rico
- Superior, 24/7/365 U.S.-based customer care

I look forward to reviewing the enclosed proposal with you and addressing any questions you may have.

Thank you.

MetTel

SOLUTION PORTFOLIO

Data & Network Solutions

Ethernet Services
MPLS
Data T1
Cable Internet
SD-WAN
Business Fiber
Managed Router
Managed Firewall
Managed Wi-Fi
IPsec & SSL VPN

Advanced Voice Solutions

Cloud PBX
Unified Communications (UC)
SIP Trunking
SIP PRI
Digital Phone

Cloud Managed Solutions

Hosted Exchange
Online Backup
IP Business
Patching & Antivirus
IT Management Services

Mobility Solutions

Mobile Device Management (MDM)
Nationwide Mobility
Fixed Wireless/Mobility
Push-to-Talk (PTT)
Mobile Help Desk
Internet of Things (IoT)
Mobile POTS

Professional & Consulting Solutions

Communications Management Platform (Bruin)
Professional Services
Managed Services

Traditional Solutions

Business Lines
Local & Long Distance
Toll-Free
High Speed Internet
ISDN PRI
PRI
Point-to-Point Private Lines
Centrex
PBX Trunks

SAVINGS SUMMARY

Contract Term: 36 Month
Date Requested: May 19, 2026
Date Fulfilled: May 19, 2026
Expiration Date: Jul 18, 2026

Quoted By: MetTel
Quote ID: SQ-00696203

CURRENT SPEND	\$ 754.03
PROPOSED RENEWAL MONTHLY SPEND	\$ 690.91
MONTHLY SAVINGS	\$ 63.12
MONTHLY SAVINGS IN %	8 %

Prepared For
Hamblen County, TN
Expiration Date
Jul 18, 2026
Authorized By

Date
May 19, 2026

Quote ID
SQ-00696203
Opportunity ID
006TQ00000cDgmmYAC
Term
36 Month

Total Locations
1

Total Current MRC
\$754.03

Total Proposed MRC
\$690.91

Monthly Charges Details

BTN	WTN	Current Plan	Location	Qty	Current Rate	Proposed Renewal Rate
BCB.154656	42.RBCB.154656	Cable HSI Static IP Address - 1	511 W 2nd North St, Morristown, TN 37814-3980 USA	1	\$24.99	\$24.99
BCB.154656	42.RBCB.154656	Cable High Speed Internet D600.0M/U35.0M	511 W 2nd North St, Morristown, TN 37814-3980 USA	1	\$225.21	\$225.21
4236216772	4236216772	DID	511 W 2nd North St, Morristown, TN 37814-3980 USA	263	\$128.87	\$65.75
4236216772	4236216772	Measured SIP Trunking(Unl Local ,1.90C Reg&LD)	511 W 2nd North St, Morristown, TN 37814-3980 USA	2	\$29.98	\$29.98
	8BYLV43	Managed Services Platinum	511 W 2nd North St, Morristown, TN 37814-3980 USA	1	\$39.99	\$39.99
	8BYLV43	MetConnect /30 (1 usable IP) VMware SDWAN Edge 640N Appliance NonWifi	511 W 2nd North St, Morristown, TN 37814-3980 USA	1	\$4.99	\$4.99
	8BYLV43	Licensed Software - SD-WAN 350Mbs	511 W 2nd North St, Morristown, TN 37814-3980 USA	1	\$300.00	\$300.00
Total				270	\$754.03	\$690.91

The foregoing Products are being purchased in accordance with the terms and conditions of the Master Service Agreement entered into by and between Customer and MetTel ("MSA"). The effective date of the Initial Term for any Product will be the date that the applicable Product is installed, delivered and/or available for use, as applicable, or, for existing Products, the date this Schedule becomes effective. This document shall constitute a "Schedule" to the MSA and is subject to the terms and conditions of the MSA. Capitalized terms used but not defined have the meanings given to them in the MSA. Above rates do not include taxes, surcharges, features and usage. Federal, state and local taxes and other items not quoted are in addition to the above services. Unless otherwise noted, equipment and installation are not included. Ethernet circuits may be delivered as Copper or Fiber. Build out charges may apply to Fiber circuits.



←
Initial here



Master Service Agreement Voice, Data & IP Services and Products

This Agreement (as further defined in Section 12) is entered into this date of _____ ("Effective Date"), by and between Manhattan Telecommunications Corporation LLC, having its principal place of business at 55 Water Street, 32nd Floor, New York, NY 10041 (hereinafter referred to as "MetTel"), and _____ having its principal place of business at _____ (hereinafter referred to as "Customer").

1. PRODUCTS AND SERVICES / TERM. Customer agrees to acquire from MetTel the services ("Services"), software ("Software") and equipment ("Equipment") identified on the schedules to this Agreement ("Schedules"), for a 36 month period, unless a different term is specified on the Schedules (as applicable, the "Initial Term"). Services, Software and Equipment are collectively referred to as "Products." The effective date of the Initial Term for any Product will be the date that the applicable Product is installed, delivered and/or available for use, as applicable, or, for existing Products, the date hereof. Customer will take all actions necessary to effectuate the Initial Term in a timely fashion.

2. RENEWAL. The Initial Term will automatically extend for additional one (1) year periods (each, an "Additional Term" and, together with the Initial Term, the "Term") at the same Monthly Equipment Rental Charges for Equipment (as established by Section 18 below), and MetTel's then standard twelve month term rates for other Products, unless either party gives the other party written notice of non-renewal at least ninety (90) days prior to the expiration of the then-current Term.

3. PAYMENT. Customer shall pay the rates and charges for Products provided under this Agreement and all applicable taxes and surcharges that may be authorized or required under laws, regulations, or tariffs in connection therewith. Except for taxes based on MetTel's net income, Customer will be responsible for all taxes, regulatory costs, fees, tariffs and surcharges arising from or in connection with an order, rule or regulation of any governmental or quasi-governmental authorities imposed on or incident to the provision, sale or use of Products, whether on Customer, MetTel, MetTel Providers or any of their affiliates. MetTel will bill Customer each month and all invoices are due and payable twenty-five (25) days after the invoice date. Customer shall send payments to the address specified on the invoice. In the event that MetTel incurs costs (collection and/or attorney fees) to recover amounts owed under this Agreement, MetTel may add these costs to any amounts outstanding. MetTel, in addition to any other remedies available to it, may impose a late fee of the greater of five (5) dollars or one and one-half percent (1.5%) per month on any charges not paid by the due date or, if less, the maximum amount allowed by law. In addition, MetTel may suspend Products, in whole or in part, if amounts owed hereunder are past due.

4. ORDERS. The Products shall be provided under the terms of this Agreement to the Customer locations specified on the Schedules. Other Customer locations, renewals or additional Products may become subject to this Agreement by submission of additional Schedules (including orders submitted via email or tickets submitted via the Portal) by or on behalf of Customer and accepted by MetTel. Each Schedule or order accepted by MetTel will commence a new Initial Term for the Products covered by the Schedule or order. POTS Transformation / replacement Services not activated by Customer within six months from Schedule acceptance will commence billing and will be deemed to commence the Initial Term as of that date. Except as expressly set forth therein rate cards (Schedules with indefinite quantities) may be discontinued by MetTel at any time other than for previously-activated Products. Equipment under a Schedule is subject to availability and pricing is subject to periodic change.

5. LIMITS ON LIABILITY. NEITHER PARTY WILL BE RESPONSIBLE TO THE OTHER FOR ANY DELAY, FAILURE IN PERFORMANCE, LOSS OR DAMAGE DUE TO FIRE, EXPLOSION, POWER BLACKOUT, EARTHQUAKE, VOLCANIC ACTION, CABLE CUTS BY THIRD PARTIES, FLOOD, WEATHER ELEMENTS, STRIKE, EMBARGO, LABOR DISPUTES, CIVIL OR MILITARY AUTHORITY, WAR, ACTS OF GOD, ACTS OR OMISSIONS OF CARRIERS OR SUPPLIERS, SOFTWARE BUGS, VIRUSES AND THE LIKE, ACTS OF REGULATORY OR GOVERNMENTAL AGENCIES, OR OTHER CAUSES BEYOND THEIR REASONABLE CONTROL (COLLECTIVELY, "FORCE MAJEURE"), EXCEPT FOR THE OBLIGATION TO PAY AMOUNTS DUE UNDER THIS AGREEMENT. AS USED IN THIS AGREEMENT, "SERVICE FAILURE" MEANS A FAILURE TO COMPLY WITH A DIRECTION OR OBLIGATION TO INSTALL, RESTORE OR TERMINATE PRODUCTS, A FAILURE TO PROVIDE PRODUCTS AND FAILURES, MISTAKES, OMISSIONS, INTERRUPTIONS, DEGRADATION, DELAYS, ERRORS, DEFECTS OR THE LIKE OCCURRING IN THE COURSE OF THE PROVISION OF PRODUCTS. THE TOTAL MAXIMUM AGGREGATE LIABILITY HEREUNDER, IF ANY, OF METTEL AND ITS AFFILIATES AND SUPPLIERS AND THEIR OFFICERS, DIRECTORS, AGENTS AND EMPLOYEES FOR DAMAGES ARISING OUT OF THIS AGREEMENT, THE RELATIONSHIP CREATED HEREBY OR OUT OF THE FURNISHING OF PRODUCTS SHALL BE LIMITED TO: (I) FOR SERVICE FAILURES: A REPAIR OR RE-PERFORMANCE OF THE SERVICE, AND A PRO-RATA REFUND OF ANY PREPAID FEES FOR CONTINUOUS SERVICE FAILURES IN EXCESS OF 24 HOURS, (II) UNLESS DIRECTLY CAUSED BY THE WILLFUL MISCONDUCT OF METTEL, NO LIABILITY FOR INJURY TO PERSONS OR PROPERTY, LOSSES (INCLUDING ANY LOSS OF BUSINESS), DAMAGES, CLAIMS OR EXPENSES OF ANY KIND CAUSED BY EQUIPMENT OR SOFTWARE, AND (III) IN ALL OTHER CASES PROVEN DIRECT DAMAGES IN AN AMOUNT LIMITED TO THE SERVICE CHARGES PAID BY CUSTOMER UNDER THIS AGREEMENT DURING THE THREE MONTHS PRECEDING THE DATE OF ACCRUAL OF THE FIRST CLAIM, EVEN IF THE OTHER LIMITATIONS OF LIABILITY SET FORTH HEREIN FAIL OF THEIR ESSENTIAL PURPOSE. IN ADDITION, NONE OF METTEL OR ITS AFFILIATES AND SUPPLIERS OR ANY OF THEIR OFFICERS, DIRECTORS, AGENTS OR EMPLOYEES WILL BE LIABLE TO THE CUSTOMER FOR ANY CONSEQUENTIAL, INDIRECT, INCIDENTAL, RELIANCE, EXEMPLARY, SPECIAL, PUNITIVE OR OTHER LIKE DAMAGES INCLUDING WITHOUT LIMITATION LOSS OF USE, PROFITS, REVENUE, BUSINESS OR GOODWILL WITH RESPECT TO ANY CLAIMS ARISING UNDER THIS AGREEMENT OR REGARDING THE PRODUCTS TO BE PROVIDED HEREUNDER, EVEN IF METTEL HAS BEEN ADVISED OF THE POSSIBILITY OF SUCH DAMAGES. WITHOUT LIMITING THE FOREGOING, IT IS EXPRESSLY UNDERSTOOD AND ACKNOWLEDGED THAT THE UNDERLYING SERVICE PROVIDER SHALL HAVE NO LIABILITY WHATSOEVER FOR CUSTOMER LOSSES, CLAIMS OR DAMAGES FOR ANY CAUSE WHATSOEVER, INCLUDING BUT NOT LIMITED TO ANY SERVICE FAILURE, REGARDLESS OF THE FORM OF ACTION, WHETHER IN CONTRACT OR IN TORT OR OTHERWISE.

6. LETTER OF AUTHORIZATION/AGENCY. MetTel will act as Customer's authorized agent for all matters related to obtaining connectivity service records and to the provisioning of local and long-distance communications services associated with all Customer's telephone numbers for which Service is ordered under a Schedule. MetTel has the authority to order local, regional, and long distance changes on all numbers associated with the accounts listed on the Schedules to this Agreement. MetTel shall not release any information regarding Customer's telecommunications services without obtaining the Customer's written approval except where required pursuant to subpoena or court order. To the extent possible, MetTel shall freeze Customer's services so that a third party (including another carrier) cannot complete a change without having the Customer contact MetTel and authorize the change.

7. CONFIDENTIAL INFORMATION. Each party shall hold in confidence and not use, except to perform its obligations hereunder, information received from the other party that is designated confidential or proprietary or that a reasonable person would treat as confidential based upon the nature of the information disclosed or the circumstances of the disclosure ("Confidential Information") for the Term and a period of 2 years thereafter. The parties agree that Confidential Information shall include the pricing and terms and conditions of this Agreement, any proposals or requests for proposals, and information relating to the disclosing party's technology, business affairs, and marketing or sales plans. Neither party shall use Confidential Information for any purpose other than in furtherance of performance under this Agreement or disclose Confidential Information to any third party other than to entities that are bound by non-disclosure obligations that are substantially similar to those set forth in this Agreement. The fact that the parties are engaged in a business relationship is not Confidential Information. Customer must obtain MetTel's written permission prior to disclosing any MetTel Confidential Information to any competitor of MetTel. The foregoing restrictions shall not apply to information that: (a) is or becomes publicly available through no act or omission of the receiving party; (b) was already in the lawful possession of the receiving party without an obligation of confidentiality; (c) is lawfully disclosed to the receiving party by a third party that is not restricted from making such disclosure; (d) is required to be disclosed by subpoena or other legal process, limited to the extent required by the terms of such subpoena or other legal process; (e) is approved in writing by the disclosing party for further disclosure; (f) is independently developed without reference to the Confidential Information and is so documented by the receiving party; or (g) is required to port telephone numbers. Receiving party acknowledges that the unauthorized use or disclosure of any such Confidential Information is likely to cause irreparable injury to disclosing party for which there is no adequate remedy at law. Accordingly, receiving party acknowledges that disclosing party may seek injunctive relief against it to prevent or remedy any breach of the confidentiality obligation described herein without disclosing party being required to post bond.

8. TERMINATION.

8.1. Default. A party shall be deemed in default of this Agreement (a "Default") upon the occurrence of any one or more of the following events:

- (a) except with respect to payment defaults, such party materially fails to perform its material obligations under this Agreement and such nonperformance is not remedied within thirty (30) days after receipt of written notice thereof, provided that if the breach is of such a nature that it cannot be cured within thirty (30) days, then such party shall not be in Default so long as it commences to cure within such period of time and thereafter diligently and continuously pursues such cure to completion; or
- (b) such party fails to make any payment under this Agreement when due and such failure is not remedied within ten (10) days after receipt of written notice thereof.

Upon the occurrence of a Default and subject to the applicable notice and cure periods and Section 8.2 below: (i) the aggrieved party may terminate or suspend the applicable Services affected by such uncured Default, and (ii) with respect to Licensed Software and/or Rented Equipment, MetTel may terminate the applicable Product. Notwithstanding the foregoing, Customer understands and agrees that Customer cannot terminate Customer's payment obligations with respect to Software or Equipment in a Schedule, which obligations are more specifically addressed in Section 17 relating to Software and Section 18 relating to Equipment prior to the end of the applicable Initial Term for any reason. The foregoing shall be in addition to any other rights and remedies that MetTel may have under this Agreement or at law, in equity or otherwise.

8.2. Effect of Termination. If Customer discontinues any Service before the expiration of the applicable Initial Term or applicable Additional Term, or if MetTel terminates this Agreement or any Service for Customer's Default, Customer will be liable to MetTel for termination charges equal to the monthly recurring charges for the applicable discontinued Services, multiplied by the number of months remaining in the Term, plus any charges MetTel incurs from third parties because of Customer's early termination of the applicable Services and for any charges that may have been waived. Customer must give MetTel prior written notice of any Service termination (using MetTel standard forms), and, in addition to the amounts set forth above, will be responsible for all charges for such Service up to the date such Service is disconnected, as well as any charges in connection with the termination. Additionally, if MetTel terminates Service, Licensed Software and/or Rented Equipment for Customer's Default, and/or Customer is in default under any Schedule, and/or any Service is discontinued before the expiration of the applicable Initial Term or applicable Additional Term without contracting for a replacement Service where any Licensed Software and/or Rented Equipment, as applicable, utilized in connection with the discontinued Service will be redeployed, in addition to the amounts set forth above, Customer will pay MetTel an amount equal to (a) any Monthly Licensed Software Charges (as established by Section 17 below), multiplied by the number of months remaining in the applicable Term, discounted at 3% per annum, related to any Licensed Software utilized in connection with the discontinued Service, plus (b) any Monthly Equipment Rental Charges (as established by Section 18 below), multiplied by the number of months remaining in the applicable Term, discounted at 3% per annum, relating to any Rented Equipment utilized in connection with the discontinued Service, plus (c) any applicable taxes; and Customer will be required to return any Rented Equipment and any other equipment supplied by MetTel in connection with the discontinued Service to the location designated by MetTel (at Customer's expense) in good working condition and free from all liens, charges and encumbrances within 10 days after termination of the Service for which it was used or of this Agreement, or Customer will pay MetTel's purchase price for the equipment as invoiced by MetTel. If MetTel assigned the Rented Equipment and right to receive Monthly Equipment Rental Charges and/or Monthly Licensed Software Charges to a third-party for financing purposes, then the assignee may exercise any of MetTel's rights and remedies independently from MetTel.

9. INTERNET & IP VOICE SERVICES DISCLOSURE.

9.1. 911 Disclosure. The Federal Communications Commission ("FCC") requires MetTel to obtain Customer's acknowledgement that it has received the following disclosures regarding possible circumstances that COULD IMPAIR YOUR ABILITY TO ACCESS E911

SERVICE: (1) if you utilize equipment that relies on electricity, you will lose E911 service (and service generally) if such devices lose access to electricity such as in a power failure. To reduce the risk of disruption, Customer should deploy a back-up power supply to operate phones and related equipment; (2) if you move your location you must notify us at least 30 days in advance so that we may program the correct information into the E911 system. Otherwise, the E911 system will not contain your correct information; (3) you may be unable to complete calls to 911 or otherwise in the event of network failures or congestion; (4) if you obtain telephone numbers that are not associated with your calling area, you may not be able to reach E911 services; (5) you must notify MetTel of any change in your designated key personnel for E911 notifications, otherwise notifications that an end-user has placed a 911 call will not be deliverable. By executing this Agreement, Customer acknowledges that it understands and accepts the above limitations, and that it will convey these limitations to all persons who may have occasion to use the Services. California multiline customers: please view additional important disclosures and informative brochure at: <https://www.mettel.net/about-mettel/legal-legal-regulatory-notice/>.

9.2. VoIP 911 Service and Acknowledgement. Please read the VoIP Schedule on the MetTel website at <http://www.mettel.net/company/voip-911.html> which is incorporated herein by reference and made a part of this agreement. If you are subscribing to VoIP Service (hosted PBX, VoIP or SIP Trunking), Customer (you) agree to the terms of the VoIP Schedule and further agree that: (1) you have received and have read and understood the terms and conditions relating to VoIP Service, including 9-1-1 service; (2) you and all users of your Service understand the nature and limits of 9-1-1 service associated with VoIP; and (3) if you change the location in which you use Service in any way, including operating Service outside of the address that you have given to MetTel, you must immediately contact MetTel, and that failure to do so may adversely affect your 9-1-1 service.

9.3. Alarm Systems and Internet Voice Application Disclosure. Please view additional important disclosures at our Policies URL concerning interoperability of VoIP and POTS replacement products with alarms systems and other legacy equipment.

10. NOTICES. Notices under this Agreement shall be sent to MetTel, Legal Department, 101 Crawfords Corner Road, Suite 4-311, Holmdel, NJ, 07733, and to Customer at the above address. Either Party may change their mailing and/or billing address by written notice in accordance with this Section. Notices may be sent by first-class U.S. mail, postage prepaid, certified, return receipt requested, or by an overnight carrier, and shall be deemed effective five (5) business days after mailing by first-class U.S. mail, one (1) business day after mailing by an overnight carrier or upon receipt.

11. MISCELLANEOUS. MetTel may perform its obligations under this Agreement through its affiliates, agents, suppliers or subcontractors (the "MetTel Providers"), but MetTel shall not be relieved of its obligations by using the MetTel Providers. MetTel may assign all or part of this Agreement to any of its affiliates or successors. MetTel may assign its rights to payments hereunder, and its rights in the Equipment and Software, to a third party for financing purposes as provided for in the Licensed Software and Equipment Rental Sections below. With reasonable prior notice, Customer may assign this Agreement to any entity that is the successor to substantially all of its assets or business, subject to MetTel's acceptance of the assignee and execution and delivery of MetTel standard assignment forms. All other attempted assignments shall be void without MetTel's prior written consent. This Agreement shall be governed by the laws of New York, without regard to its choice of law principles, and the venue for any legal action or litigation involving this Agreement and all proceedings, depositions etc. in such action or litigation shall be held exclusively within New York County and the courts of the State of New York, or the federal courts of the United States of America in New York. Notwithstanding the foregoing, any claim related to Rented Equipment or the payments due under a Schedule and attributable to Rented Equipment shall be governed by the internal laws of the state in which MetTel (or, if such rights to Rented Equipment are assigned, then MetTel's assignee's) principal place of business is located. Any dispute concerning the Rented Equipment or the payments due under a Schedule and attributable to Rented Equipment will be adjudicated in a federal or state court in such state. Customer hereby consents to personal jurisdiction and venue in such courts and waives transfer of venue. Customer and MetTel acknowledge and agree that each party has been represented by independent counsel of its own choosing in the negotiation and execution of this Agreement. Each party agrees that any cause of action or claim will be resolved individually and Customer agrees that it will not consolidate or seek class treatment for any claims in connection with this Agreement, unless previously agreed to in writing by both parties. If any part of this Agreement is rendered invalid or unenforceable, the rest of the Agreement will remain valid and enforceable. Provisions of this Agreement that by their terms or nature must survive expiration or termination of this Agreement, will survive expiration or termination of this Agreement, including, but not limited to Sections 3, 5, 7, 8, 11 – 18 and 20 – 22. Failure to insist on strict performance of any of the terms and conditions of this Agreement will not operate as a waiver thereof or of any subsequent default or failure of performance, and no waiver by either party of any breach shall be construed as a waiver of any subsequent breach or as a waiver of the provision itself or any other provision. Purchase orders or other non-MetTel ordering documents relating to Products issued by Customer containing different or additional terms will be construed solely as evidence of Customer's internal business processes and will have no effect on this Agreement or any Products except to the extent evidencing acceptance of a Schedule. If objection is not received by MetTel within three months after an invoice is rendered, the items and charges appearing thereon shall be determined to be correct and binding upon Customer. Customer authorizes MetTel to monitor and record calls to or from MetTel concerning the Services for MetTel's training and quality control purposes.

12. TARIFFS, SERVICE PUBLICATIONS, ENTIRE AGREEMENT. This Agreement consists of (in order of priority): (i) the terms in the body of this Master Service Agreement ("MSA"), (ii) any attachments incorporated herein by reference (iii) any attachments and Schedules later added to this agreement ((ii) and (iii), collectively, "Attachments") (iv) MetTel product guides, price lists and product use terms (collectively, "Service Publications") and (v) any applicable tariffs ((i) – (v) collectively, the "Agreement"). This Agreement constitutes the entire agreement between the parties with respect to the subject matter hereof and supersedes all other representations, understandings or agreements that are not expressed herein, whether oral or written. The rates, terms and conditions that apply pursuant to applicable tariffs are subject to change in accordance with the rules of applicable state regulatory commission and/or Federal Communications Commission. Service Publications are found on the MetTel website (<https://www.mettel.net/about-mettel/legal/tariffs-product-guides/>) as of the date of this Agreement, referred to hereafter as the "Policies URL"), are subject to change from time to time when updated on the MetTel website and are incorporated herein by reference to the extent they do not conflict with the terms of the MSA or any Schedule. Except as otherwise set forth herein, no amendment, waiver or modification of this Agreement shall be valid unless in writing and signed by both parties. Handwritten changes to this Agreement (including without limitation any Attachment) are not valid. This Agreement may be executed in one or more counterparts, each of which will be deemed to be an original copy of this Agreement and all of which, when taken together, will be deemed to constitute one and the same agreement.

13. USE OF PRODUCTS. Products purchased under this contract cannot be resold. Customer agrees that it is responsible and accepts full liability for all use of the Products, with or without its permission, and will not resell the Products purchased under this Agreement or distribute/ transfer the Products purchased under this Agreement to any person or entity other than its employees. The Products may not be used for any unlawful, abusive, or fraudulent purpose, in violation of the then-current acceptable use policy ("AUP") located at the Policies URL or another designated url, to support illegal robocalling activity, or in any way that violates or infringes upon the rights of others. Customer agrees to promptly reply, and assist MetTel to reply, to a request from law enforcement or a traceback administrator authorized by USTelecom's Traceback Group for information about suspicious robocalls that have been sent to a downstream provider. Customer shall defend, indemnify and hold harmless MetTel and its affiliates and suppliers and their respective officers, directors, agents, affiliates, and employees from and against any claims, liabilities, losses, costs, or damages, (including legal fees and costs) arising out of any user's use or attempted use of Products. Broadband speed claim(s) represent maximum downstream and/or upstream speed capabilities which may vary and are not guaranteed. Factors including line quality and Customer's distance from the exchange may limit available bandwidth.

14. WARRANTIES. CUSTOMER AGREES THAT THE PRODUCTS ARE PROVIDED ON AN "AS IS" OR "AS AVAILABLE" BASIS, WITH ALL FAULTS, AND THAT METTEL DOES NOT WARRANT THAT THE PRODUCTS WILL BE WITHOUT FAILURE, DELAY, INTERRUPTION, ERROR, DEGRADATION OF QUALITY OR LOSS OF CONTENT, DATA OR INFORMATION, AND SPECIFICALLY DISCLAIMS ANY AND ALL EXPRESS OR IMPLIED WARRANTIES AS TO ANY PRODUCTS, INCLUDING WITHOUT LIMITATION ANY IMPLIED WARRANTIES OF MERCHANTABILITY, FITNESS FOR A PARTICULAR PURPOSE, TITLE OR NONINFRINGEMENT OF THIRD PARTY RIGHTS. METTEL IS NOT THE MANUFACTURER OF ANY EQUIPMENT. WITH RESPECT TO METTEL, CUSTOMER PURCHASES OR RENTS THE EQUIPMENT, AS APPLICABLE, "AS IS." EQUIPMENT SHALL BE SUBJECT TO THE WARRANTIES, IF ANY, PROVIDED TO CUSTOMER BY THE EQUIPMENT MANUFACTURER. MODIFICATIONS MAY VOID OR OTHERWISE LIMIT ANY WARRANTY APPLICABLE TO THE EQUIPMENT. WITH RESPECT TO SECURITY PRODUCTS INCLUDING WITHOUT LIMITATION CLOUD FIREWALL & SASE, CUSTOMER HEREBY ACKNOWLEDGES AND AGREES THAT NO VENDOR CAN ASSURE COMPLETE SECURITY AND NOTHING HEREIN OR ELSEWHERE SHALL BE DEEMED TO IMPLY A SECURITY GUARANTEE OR ASSURANCE.

15. UNAUTHORIZED USAGE. It is understood that MetTel is under no obligation to investigate the authenticity of calls charged to Customer's account and shall not be liable for any fraudulent or unauthorized calls processed by MetTel and billed to Customer's account. Notwithstanding, in the event MetTel discovers or reasonably suspects fraudulent calls are being made, or that the Services are being used in connection with (i) illegal, fraudulent or abusive activity, (ii) activity that places MetTel's (or its providers') network at risk or could subject MetTel (or its providers) to liability to a third party or (iii) in a manner that violates this Agreement, the AUP or infringes the rights of a third party (including without limitation, to support illegal robocalling activity), nothing contained herein shall prohibit MetTel from taking immediate action, without notice to Customer, that is reasonably necessary to prevent such calls or transmissions from taking place, but is under no obligation to do so.

16. HOSTED PRODUCTS. This section applies solely to MetTel-hosted Services, including hosted PBX. MetTel will provide Customer with password-protected access to its hosted Service(s). Passwords are selected by Customer or its end-users, and Customer shall be solely and exclusively responsible for protecting all account passwords and the use and control of access to Customer's account.

17. LICENSED SOFTWARE. This section applies to all SD-WAN services and any other Products listed on a Schedule designated as "Licensed Software" on such Schedule. By Customer's acceptance of the terms of such Schedule, Customer thereby agrees to pay MetTel the monthly amounts set forth on the Schedule relating to the Licensed Software, plus applicable taxes (the "Monthly Licensed Software Charges") for the Initial Term of the applicable Licensed Software. The Initial Term for Licensed Software will commence on the earlier of (i) the date of activation of the Licensed Software, or (ii) ninety (90) days after the date of shipment of the Equipment associated with the Licensed Software (if any). Notwithstanding anything to the contrary, Customer understands and agrees that Customer is unconditionally obligated to pay all Monthly Licensed Software Charges for the applicable Initial Term, and is not entitled to withhold any Monthly Licensed Software Charges or reduce or set-off against any amounts owed relating to the Licensed Software for any reason. Licensed Software cannot be discontinued before the expiration of the applicable Initial Term for any reason. At the conclusion of the Term, Licensed Software and Customer's obligation to pay Monthly Licensed Software Charges relating thereto will automatically terminate without further action required by either party, unless MetTel in its sole discretion allows a limited month to month extension, subject to authorization from the underlying provider. Customer understands that MetTel may assign Customer's payment obligations relating to any Licensed Software to a third-party for financing purposes and that, if assigned, the assignee will have all of MetTel's rights to receive the Monthly Licensed Software Charges, but will not be subject to any claim, defense, or set-off assertable against MetTel or anyone else.

18. RENTED EQUIPMENT. This section applies to any Equipment listed on a Schedule designated as "Rented Equipment" on such Schedule and all Equipment provided under a Schedule for a monthly fee. By Customer's acceptance of the terms of the Schedule, Customer thereby agrees to rent the Rented Equipment and pay MetTel the monthly amounts set forth on the Schedule relating to the rental of the Rented Equipment, plus applicable taxes (the "Monthly Equipment Rental Charges") for the Initial Term designated on the Schedule for the applicable Rented Equipment. The Initial Term for any Rented Equipment will commence on the date the applicable Rented Equipment is delivered or any later date designated by MetTel. Notwithstanding anything to the contrary, Customer understands and agrees that Customer is unconditionally obligated to pay all Monthly Equipment Rental Charges for the Initial Term, and is not entitled to withhold Monthly Equipment Rental Charges or reduce or set-off against any amounts owed relating to the rental of the Rented Equipment for any reason. Customer's obligations with respect to Rented Equipment cannot be discontinued before the expiration of the applicable Initial Term for any reason. Customer agrees to keep the Rented Equipment in good working order, use it for business purposes only, not modify or move it from its initial location without MetTel's consent and to keep the Rented Equipment fully insured against loss at its replacement cost, with MetTel named as loss payee, and to provide proof of such insurance satisfactory to MetTel upon MetTel's request. Customer will be responsible for any damage to or loss of the Rented Equipment, and understands that no such loss or damage to the Rented Equipment will relieve Customer from its obligation to make all Monthly Equipment Rental Charges for the entire Initial Term. MetTel owns the Rented Equipment and is authorized to file UCC financing statements to reflect its interest in the Rented Equipment. Customer agrees to pay when due, either directly or by reimbursing MetTel, for all taxes and fees relating to the Rented

Equipment (including, but not limited to, sales or use tax due upfront which will be payable over the Initial Term with a finance charge). Customer's obligations with respect to the Rented Equipment (including, but not limited to, Customer's obligation to pay Monthly Equipment Rental Charges) shall continue on a month to month basis after the end of the Initial Term, or any subsequent Additional Term, unless Customer (A) provides MetTel at least thirty (30) days prior written notice that Customer has determined to return the Rented Equipment at the end of the applicable Initial Term or Additional Term and (B) Customer timely returns the Rented Equipment to the location designated by MetTel, at Customer's expense. If the returned Rented Equipment is not immediately available for use by another customer without need of repair, Customer will reimburse MetTel for all repair costs. Customer understands that MetTel may assign the Rented Equipment and Customer's payment obligations relating to the Rented Equipment to a third-party for financing purposes and that, if assigned, the assignee will have all of MetTel's rights with respect to the Rented Equipment and Customer's payment obligations relating to the Rented Equipment, but will not be subject to any claim, defense, or set-off assertable against MetTel or anyone else. All Schedules, orders or attachments that include equipment are subject to review and approval by MetTel credit, and may require a deposit. Equipment prices do not include shipping charges, which will be the responsibility of Customer. Risk of loss or damage to any Equipment (including portions thereof) and Software passes to Customer on delivery to the freight carrier. Notwithstanding the foregoing, if MetTel and Customer enter into a separate rental or finance agreement relating to any equipment provided by MetTel (an "Equipment Use Agreement"), Customer's obligations with respect to such equipment (payment or otherwise) shall be solely governed by the Equipment Use Agreement, and any modification or termination of this Agreement or the Services shall not operate to modify or relieve Customer from any of Customer's obligations under the Equipment Use Agreement. An Equipment Use Agreement may be required for orders with significant Equipment. Amounts owed MetTel under any Equipment Use Agreement are not included in the charges for the Services, Software or Equipment under this Agreement, though such amounts may be invoiced along with the charges owed by Customer to MetTel under this Agreement for Customer's convenience. Customer agrees to execute and return a Delivery Confirmation statement to MetTel reflecting Rented Equipment received. Each Schedule containing Rented Equipment is (or shall be treated as) a "Finance Lease" as that term is defined in Article 2A of the Uniform Commercial Code ("UCC"). Customer agrees to forgo the rights and remedies provided under sections 507-522 of Article 2A of the UCC with respect to Rented Equipment on a Schedule.

19. INSTALLATIONS. Installation means Service delivery to the demarcation point (the MetTel designated physical interface between the MetTel Service and Customer's telecommunications equipment) which is generally at the MPOE (minimum point of entry). Service, wiring (including extensions of the demarcation point) and equipment for use on Customer's side of the demarcation point are the responsibility of Customer and may be provided by MetTel at an additional cost. Installation does not include buildout or the construction of facilities (if applicable). Cloud-based Services like cloud firewall or SIP call paths are installed and active when the service has been enabled for use in the cloud. Software and Equipment (including Equipment provided in connection with a Service like Starlink) does not include installation except as specified in a Schedule.

20. METTEL SOFTWARE.

(A) Use. The following terms apply to any software application embedded in CDS Products and any software application provided to Customer for use with the Service for which there is not a specified monthly payment provided for in a Schedule including, without limitation, the Bruin portal at app.Bruin.com (including any successor, "Portal"), in each case, provided by or on behalf of MetTel ("MetTel Software"). Subject to compliance with this Agreement, and except where a separate license is provided, MetTel hereby grants to Customer a non-exclusive, non-transferable, non-sublicensable, revocable license to use such MetTel Software in object code form only and solely by Customer for Customer's internal business purposes in connection with the Services during the Term. MetTel Software will be deemed a Service under this Agreement but not subject to a Term unless otherwise identified and provided as a separate Service under a Schedule to this Agreement or embedded in another Product. Customer may not and may not permit others to (i) provide, disclose or make MetTel Software available to any third party, or (ii) copy, decompile, reverse engineer, disassemble, modify, rent, lease, loan, distribute, or create derivative works (as defined by the U.S. Copyright Act) or improvements (as defined by U.S. patent law) from, the MetTel Software or any portion thereof, or otherwise attempt to discover the source code or underlying ideas, algorithms, structure or organization of, or reproduce the design of, the MetTel Software or components thereof. Customer agrees that MetTel Software contains proprietary content, design, information and material that is protected by applicable intellectual property and other laws, including but not limited to copyright, and will not use or permit use of such proprietary content, information or materials in any way whatsoever except for permitted use of the MetTel Software provided under this Section. MetTel reserves the right to modify the Portal or upgrade its online and software-based services from time to time. Customer shall be solely and exclusively responsible for protecting all account passwords and the use and control of access to Customer's account. Except for limited rights to use MetTel Software, no license under patents, copyrights, trademarks, service marks, trade names or other indicia of origins or other right is granted to Customer in the MetTel Software or in MetTel's trademark, copyright, patent, trade secret or other proprietary rights nor shall any such rights be implied or arise by estoppel with respect to any transactions contemplated under this Agreement.

(B) Feedback. Customer or its employees may communicate to MetTel suggested modifications, design changes, or improvements to the MetTel Software ("Feedback"). Customer agrees that MetTel will have any and all rights and interests in any Feedback without the payment of any consideration, and that any Feedback will be considered Confidential Information.

21. CUSTOMER PROPRIETARY NETWORK INFORMATION ("CPNI"). Pursuant to federal law, CPNI is (A) information that relates to the quantity, technical configuration, type, destination, location, and amount of use of a telecommunications service subscribed to by Customer, and that is made available to MetTel by Customer solely by virtue of the carrier-customer relationship; and (B) information contained in the bills pertaining to telephone service received by Customer. MetTel will not use, disclose, or permit access to Customer's CPNI except in its provision of services from which such information is derived, or as authorized or required by federal law, or as expressly authorized by Customer. To protect customers' CPNI from inappropriate disclosure to unauthorized third parties, MetTel has implemented strict safeguards that restrict the ability of MetTel representatives to disclose certain information to or permit certain changes to accounts by inbound callers or visitors to MetTel's offices and that regulate MetTel's ability to provide customers with account access over online portals. The FCC permits business customers and their telephone service providers to agree to flexible customer authentication methods that are suited to an efficient business relationship. Customer hereby agrees that its MetTel dedicated account representative and MetTel customer support personnel who are responsible for commercial accounts may disclose Customer CPNI or make changes to Customer's account at the request of persons that they reasonably believe to be Customer's authorized representatives and that MetTel may provide

online access to Customer CPNI via the Portal or in any commercially reasonable manner, and that third parties authorized in writing to MetTel may have access to Customer's CPNI. Customer may at any time contact its dedicated account representative to request access to its CPNI. Customer hereby authorizes MetTel to share Customer CPNI with Customer's agents and employees as though such persons were the Customer hereunder; such authorization may be withdrawn as to any person or entity at any time upon written notice to MetTel. Customer agrees that MetTel may share CPNI with its affiliates, agents, and partners relating to business operations, and with businesses acting on MetTel's behalf, to determine if Customer could benefit from the wide variety of MetTel and Affiliate, agent, partner products and services, and in its marketing and sales activities. Customer may withdraw its authorization at any time by informing MetTel in writing. Customer's decision regarding MetTel's use of CPNI will not affect the quality of Service MetTel provides to Customer.

22. FIXED-RATE SERVICES. For purposes of this Agreement, "Fixed-Rate Services" means Services for which MetTel's underlying rates and charges do not change during the applicable Term. Rates, discounts and terms for any Services for which MetTel's underlying costs from the underlying carrier change are subject to change from time to time, subject to any applicable tariffs.

23. PRIVATE LINE / MPLS. Where Customer is ordering private line or MPLS service from MetTel, the end points for which are located in the same state, Customer agrees that MetTel will classify such services as jurisdictionally interstate and pass through applicable taxes and surcharges accordingly, such as the federal Universal Service Fund surcharge, unless by checking this box [Initials _____] Customer warrants and certifies that ten percent (10%) or less of the traffic across each such service is and will be interstate. Under FCC rules, it is the nature of the traffic itself, and not the physical endpoints of the facility provided by MetTel, that determines jurisdiction. For example, Internet traffic is interstate when used to connect to content delivered from a different state or country. Customer shall notify MetTel within 15 days if the foregoing certification is no longer valid.

24. LEGAL AND REGULATORY CHANGES. If any law, regulation or other action of a government authority (collectively a "Government Action") after the Effective Date affects the charges or allocation or collection of costs under this Agreement, the parties agree that MetTel may adjust the charges under this Agreement to conform to such Government Action while collecting the same charges that would have been collected absent the Government Action.

25. SUNSET AND TECHNOLOGY TRANSITION. MetTel will not sunset any Services during the Term without providing Customer at least 30 days prior written notice or, if longer, such period required by applicable law, prior to the sunset date and will continue to provide the sunseting Services at the rate provided in this Agreement through the sunset date, after which such Services will be disconnected. No Service disconnected in connection with a sunset by MetTel will incur termination charges. Customer may elect to terminate the sunseting Services at any time during the period preceding the sunset date, at which time MetTel will provide reasonable assistance in coordinating cutover to Services provided by other carriers. In addition, MetTel may transition Products to alternatives providing substantially similar functionality provided the aggregate monthly recurring charges for the new Products are not greater than such charges for the Product being replaced. Such replacements will not be a sunset within the meaning of this Section.

26. CREDIT REVIEW. Service acceptance by MetTel is subject to MetTel's initial and continuing credit approval procedures and policies. MetTel reserves the right to withhold initiation or full implementation of any or all Services or delivery of any equipment under this Agreement pending MetTel's satisfactory review and approval thereof which may be conditioned upon terms specified by MetTel, including but not limited to security for payments due hereunder.

27. TECHNOLOGY MIGRATION. Customer has retained MetTel to assist with technology migration and replacement of its TDM voice Services such as POTS, Centrex, PRI and BRI (collectively, "Legacy Services") with new technology. As such, Customer agrees and hereby requests that wherever reasonably possible MetTel replace any Legacy Services provided under this Agreement with alternate Products (including without limitation, Services using Voice over IP) providing substantially similar functionality, provided in each case that the aggregate monthly recurring charges for the replacement Products (excluding taxes and surcharges) are not greater than such charges for the replaced Legacy Service, and that such charges will not be increased over a new thirty-six month Initial Term that the parties agree will begin upon activation of the replacement Product ("Replacement Product"). Upon either party's request the parties will prepare and execute a Schedule setting forth the Replacement Product and will work in good faith to complete conversion to the Replacement Product, including without limitation, by providing site access to complete the installation.

IN WITNESS WHEREOF, the parties have caused this Agreement to be executed by their respective duly authorized officers, each copy of which will for all purposes be deemed to be an original.

AGREED AND ACCEPTED:

Customer: _____
Billing Address: _____

Signature By _____
Print Name and Title _____
Contact Tel: _____ E-mail _____
Fed. Tax ID _____

Manhattan Telecommunications Corporation LLC
Signature By _____

Print Name: _____
Title _____

Hamblen County Government



Annual Debt Report

For the Year Ending June 30, 2026

Chris Cutshaw
County Mayor

Amanda Hale
Finance Director

Hamblen County, Tennessee
Annual Debt Report for the Fiscal Year Ending June 30, 2026
Table of Contents

	Page (s)
Letter to Hamblen County Commissioners and Citizens	1
Schedule of Changes in Long-term Other Loans and Bonds	2
Percentage of Debt - Hamblen County Government and Hamblen County School Department	3
Schedule of Budgeted Debt Payments - for fiscal year ending June 31, 2026	4
Benchmarks:	
Debt per Capita	5
Net Debt and Net Debt Per Capita	6
Debt as a Percentage of Median Household Income	7
Net Debt as a Percentage of Median Household Income	8
Debt to Assessed Property Value	9
Net Debt to Assessed Property Value	10
Debt Requirements:	
Schedule of Long-term Debt Requirements by Year - Total	11
Schedule of Long-term Debt Requirements by Year - By Debt Type	12
Schedule of Long-term Debt Requirements by Year - Qualified School Construction Bonds	13
Schedule of Long-term Debt Requirements by Year - USDA Rural Development Loan	14
Schedule of Long-term Debt Requirements by Year - General Obligation Bonds, Series 2020A	15
Schedule of Long-term Debt Requirements by Year - General Obligation Bonds, Series 2021	16
Schedule of Long-term Debt Requirements by Year - General Obligation Bonds, Series 2022	17
Schedule of Long-term Debt Requirements by Year - General Obligation Bonds, Series 2023	18
Schedule of Long-term Debt Requirements by Year - Capital Outlay Note, Series 2023 (Shredder)	19
Schedule of Long-term Debt Requirements by Year - General Obligation Bonds, Series 2024A (Landfill)	20
Schedule of Long-term Debt Requirements by Year - General Obligation Bonds, Series 2024B (School - Wall Project)	21
Schedule of Long-term Debt Requirements by Year - General Obligation Bonds, Series 2025 (School -Wall Project)	22
Charts:	
Total Payments	23
Principal Payments	24
Percentage of Debt - Hamblen County Government to Hamblen County School Department	25
Debt per Capita Comparison with Surrounding Counties	26
History of Debt - Hamblen County 2013 - 2025	27
Total Debt Payments Compared to Estimated Annual Revenue	28

Hamblen County's Debt Management Policy is on the Hamblen County website at www.HamblenCountyTN.gov



T E N N E S S E E
Hamblen County

SERVICE • COMMUNITY • INDUSTRY

OFFICE OF THE MAYOR

To: Rodney Long, Hamblen County Finance Committee Chairman
Hamblen County Commissioners
Hamblen County Citizens and All Interested Parties

From: Chris Cutshaw, County Mayor *CC*
Amanda Hale, Finance Director *AH*

Date: 6/12/26

Re: Annual Debt Report

In compliance with Section II.B of Hamblen County's Debt Management Policy, we present the Annual Debt Management Report for the fiscal year ending June 30, 2026. It is our goal to demonstrate strong financial management practices to the citizens of Hamblen County, investors, and credit agencies. We will continue our practice of strategic planning to issue and manage debt based on focused long-term goals.

Hamblen County received a rating of Aa3 from Moody's Investors Service, and an AA- from Standard and Poor's during its most recent ratings review. These ratings are a positive reflection of Hamblen County's solid financial position, conservative budgetary practices, and well managed debt profile. These ratings allow Hamblen County to obtain financing at lower interest rates, which in return results in a lower tax burden on its citizens.

The most recent ratings are further supported by comparing selected ratios to national benchmarks. Based on the projected outstanding principal at June 30, 2026, Hamblen County's net debt to assessed property value is 4.66 percent compared to a national benchmark which recommends a percentage of no more than 10 percent. Additionally, Hamblen County's net debt-per-capita ratio of \$1,731 is considered in the low category in Standard & Poor's classification system for setting credit ratings. Finally, Hamblen County's net debt as a percentage of median household income is 3.49 percent as compared to the benchmark which recommends a percentage of 4.5 percent or less. Each of these ratios individually, and in combination, reinforces the County's strong financial management practices. Hamblen County also compares favorably with surrounding counties.

As we move into the 2026-2027 fiscal year, we think that our Budget Committee and County Commission has adopted an adequately funded debt budget that meets the present and future needs of the citizens of Hamblen County.

Chris Cutshaw, County Mayor

511 West Second North Street • Morristown, TN 37814 • office. 423.586.1931 • fax. 423.585.4699

www.HamblenCountyTN.gov • email. Chris.cutshaw@co.hamblen.tn.us

[Return to Regular Calendar](#)

Hamblen County, Tennessee
Annual Debt Report
Schedule of Changes in Long-term Other Loans and Bonds
For Year Ending June 30, 2026

Description of Indebtedness	Original Amount of Issue	Interest Rate	Date of Issue	Last Maturity Date	Outstanding 6/30/2025	Issued During Period	Paid and/or Matured During Period	Outstanding 6/30/2026
<u>OTHER LOANS PAYABLE</u>								
<u>Payable through General Debt Service Fund</u>								
Qualified School Construction Bonds (2)	\$ 11,280,000	1.515 %	12-17-09	7-1-26	839,495	-	773,140	66,355
USDA Rural Development Loan (3)	\$ 360,000	0 %	6-30-20	5-1-30	196,667	-	40,000	156,667
Capital Outlay Note, Series 2023 (Landfill Shredder)	\$ 900,000	4.76%	12-28-23	12-1-28	746,086	-	173,720	572,366
Total Payable through General Debt Service Fund					<u>\$ 1,782,248</u>	<u>\$ -</u>	<u>\$ 986,860</u>	<u>\$ 795,388</u>
Total Other Loans Payable					<u>\$ 1,782,248</u>	<u>\$ -</u>	<u>\$ 986,860</u>	<u>\$ 795,388</u>
<u>BONDS PAYABLE</u>								
<u>Payable through General Debt Service Fund</u>								
General Obligation Bonds, Series 2020A	\$ 19,995,000	2-5 %	1-31-20	6-1-49	17,675,000	-	740,000	16,935,000
General Obligation Bonds, Series 2021	\$ 9,405,000	2-4%	12-17-21	6-1-51	8,960,000	-	345,000	8,615,000
General Obligation Bonds, Series 2022	\$ 91,025,000	4-5%	5-13-22	5-1-52	88,175,000	-	2,850,000	85,325,000
General Obligation Bonds, Series 2023	\$ 4,275,000	4-5%	2-10-23	2-10-37	3,815,000	-	245,000	3,570,000
General Obligation Bonds, Series 2024A (Landfill)	\$ 6,290,000	4-5%	8-16-24	6-1-44	6,290,000	-	-	6,290,000
General Obligation Bonds, Series 2024B (School - Walls)	\$ 3,355,000	4-5%	8-16-24	6-1-44	3,355,000	-	-	3,355,000
General Obligation Bonds, Series 2025	\$ 9,650,000	4-5%	9-30-25	6-1-46	-	9,650,000	-	9,650,000
Total Payable through General Debt Service Fund					<u>\$128,270,000</u>	<u>\$ 9,650,000</u>	<u>\$ 4,180,000</u>	<u>\$ 133,740,000</u>
Total Bonds Payable					<u>\$128,270,000</u>	<u>\$ 9,650,000</u>	<u>\$ 4,180,000</u>	<u>\$ 133,740,000</u>
TOTAL DEBT					<u>\$130,052,248</u>	<u>\$ 9,650,000</u>	<u>\$ 5,166,860</u>	<u>\$ 134,535,388</u>

- (1) These issues were swapped to a synthetic fixed rate by execution of swap agreements in prior years.
- (2) As of June 30, 2026 Hamblen will have deposited \$11,280,000 in the QSCB sinking fund held by the State of Tennessee, leaving a total of \$0 remaining to be deposited. The State of Tennessee holds the sinking fund payments in escrow and will pay off the full \$11,280,000 in 2027.
- (3) This is a USDA Rural Development Loan through Appalachian Electric Cooperative under a revolving loan program established pursuant to agreements with or through Rural Business - Cooperative Services under a Federal Rural Economic Development Loan and Grant Program.

Hamblen County, Tennessee
Annual Debt Report
Percentage of Debt - Hamblen County Government to Hamblen County School Department
For Year Ending June 30, 2026

Description of Indebtedness	Percentage	Percentage	Amount	Amount	Total
	of Outstanding Balance Related to Hamblen County General Government	of Outstanding Balance Related to Hamblen County School Department	of Outstanding Balance Related to Hamblen County General Government	of Outstanding Balance Related to Hamblen County School Department	
<u>OTHER LOANS PAYABLE</u>					
<u>Payable through General Debt Service Fund</u>					
Qualified School Construction Bonds	0.00%	100.00%	-	66,355	66,355
USDA Rural Development Loan	100.00%	0.00%	156,667	-	156,667
Capital Outlay Note, Series 2023 (Landfill Shredder)	100.00%	0.00%	572,366	-	572,366
Total Payable through General Debt Service Fund			<u>\$ 729,033</u>	<u>\$ 66,355</u>	<u>\$ 795,388</u>
Total Other Loans Payable			<u>\$ 729,033</u>	<u>\$ 66,355</u>	<u>\$ 795,388</u>
<u>BONDS PAYABLE</u>					
<u>Payable through General Debt Service Fund</u>					
General Obligation Bonds, Series 2020A	47.99%	52.01%	8,127,106	8,807,894	16,935,000
General Obligation Bonds, Series 2021	100.00%	0.00%	8,615,000	-	8,615,000
General Obligation Bonds, Series 2022	77.40%	22.60%	\$ 66,041,550	\$ 19,283,450	\$ 85,325,000
General Obligation Bonds, Series 2023 (Landfill)	100.00%	0.00%	\$ 3,570,000	\$ -	\$ 3,570,000
General Obligation Bonds, Series 2024A (Landfill)	100.00%	0.00%	\$ 6,290,000	\$ -	\$ 6,290,000
General Obligation Bonds, Series 2024B (School - Walls)	0.00%	100.00%	\$ -	\$ 3,355,000	\$ 3,355,000
General Obligation Bonds, Series 2025 (School - Walls)	0.00%	100.00%	\$ -	\$ 9,650,000	\$ 9,650,000
Total Payable through General Debt Service Fund			<u>\$ 92,643,656</u>	<u>\$ 41,096,344</u>	<u>\$ 133,740,000</u>
Total Bonds Payable			<u>\$ 92,643,656</u>	<u>\$ 41,096,344</u>	<u>\$ 133,740,000</u>
TOTAL DEBT	69.40%	30.60%	<u>\$ 93,372,689</u>	<u>\$ 41,162,699</u>	<u>\$ 134,535,388</u>

Hamblen County, Tennessee
Annual Debt Report
Schedule of Budgeted Debt Payments
For Year Ending June 30, 2026

	Principal	Interest
Other Loans:		
Qualified School Construction Bonds	773,140	182,172
USDA Rural Development Loan	40,000	-
Capital Outlay Note, Series 2023 (Landfill Shredder)	<u>173,720</u>	<u>31,379</u>
Total Other Loans	<u><u>\$ 986,860</u></u>	<u><u>\$ 213,551</u></u>
Bonds:		
General Obligation Bonds, Series 2020A	\$ 740,000	\$ 517,787
General Obligation Bonds, Series 2021	345,000	232,995
General Obligation Bonds, Series 2022	2,850,000	3,883,950
General Obligation Bonds, Series 2023 (Landfill)	245,000	163,200
General Obligation Bonds, Series 2024A (Landfill)	-	266,450
General Obligation Bonds, Series 2024B (School-Walls)	-	145,550
General Obligation Bonds, Series 2025	-	276,983
Total Bonds	<u><u>\$ 4,180,000</u></u>	<u><u>\$ 5,486,915</u></u>
TOTAL BUDGETED DEBT PAYMENTS	<u><u>\$ 5,166,860</u></u>	<u><u>\$ 5,700,466</u></u>

Hamblen County, Tennessee
Annual Debt Report
Debt Per Capita

Calculation Method:

$$\text{Debt Per Capita} = \frac{\text{Total Debt of the County}^1}{\text{County's Population}}$$

	6/30/2024	6/30/2025	6/30/2026
Total Debt	\$ 125,490,016	\$ 130,052,248	\$ 134,535,388
Population	66,216	68,800	69,500
Debt Per Capita	\$ 1,895	\$ 1,890	\$ 1,936

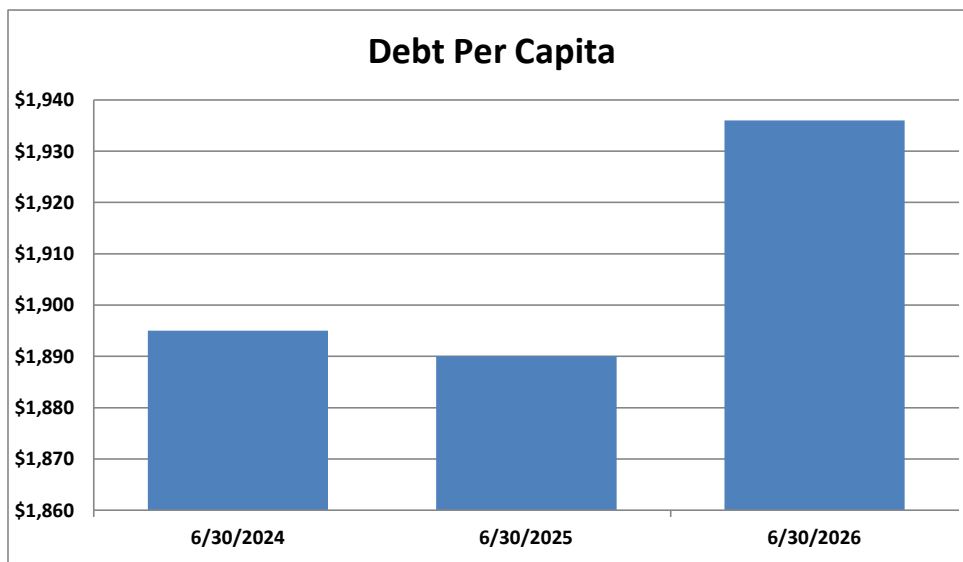

Debt Per Capita - This ratio is used in evaluating the county's ability to pay off its debt by taking the total principal on outstanding debt divided by the total citizens in the county.

Most recent population data per U.S. Census Bureau.

¹ Principal amount only (any interest expense that would be due is not included)

Hamblen County, Tennessee
Annual Debt Report
Net Debt and Net Debt Per Capita

Calculation Method:

$$\text{Net Debt Per Capita} = \frac{\text{Net Debt of the County}^1}{\text{County's Population}}$$

	Benchmark	Hamblen County
Total Debt		\$ 134,535,388
Less: Projected Year Fund Balance in the General Debt Service Fund		(14,222,822)
Net Debt		<u>\$ 120,312,566</u>
Population		<u>69,500</u>
Net Debt Per Capita - S & P's Low Category	<u>\$2,000</u>	<u>\$ 1,731</u>

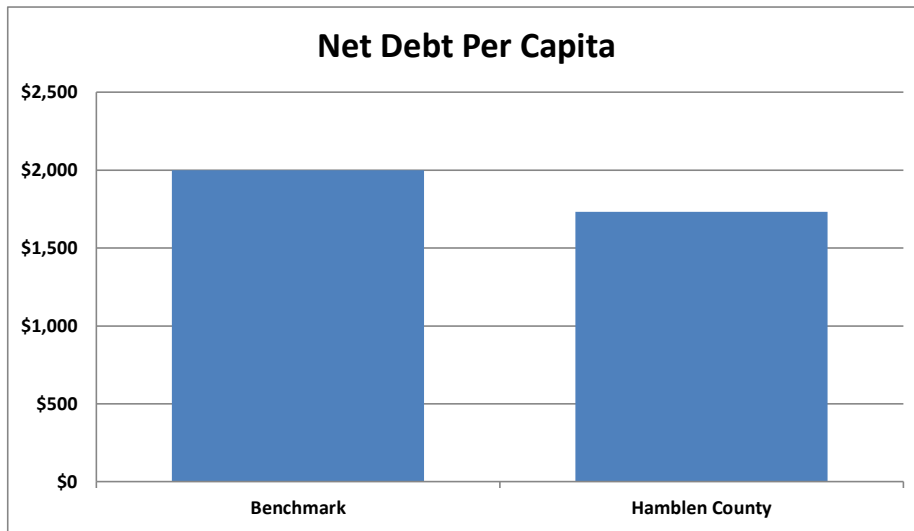

Net Debt - Net debt is the outstanding principal less the fund balance that is currently available in the General Debt Service Fund. This allows Hamblen County to determine the amount required to be collected in the future to retire the outstanding principal on its debt.

Net Debt Per Capita - Net debt per capita is calculated by dividing the net debt by the total number of citizens of Hamblen County. This is the additional amount that Hamblen County would need to collect from every citizen in order to retire its outstanding principal balance. Simply stated, if every citizen remitted an additional \$1,731 to Hamblen County at June 30, Hamblen County would be able to retire all of its debt excluding the interest component at one time. For comparison, Standard and Poor's classifies governments with net debt of between \$1,500 in and \$2,000 net debt per capita as having a low debt burden.

¹ Principal amount less projected year-end fund balance (any interest expense that would be due is not included)

Hamblen County, Tennessee
Annual Debt Report
Debt as a Percentage of Personal Income

Calculation Method:

$$\text{Debt as Percentage of Median Household Income} = \frac{\text{Total Debt of the County}^1 / \text{County's Population}}{\text{Median Household Income}}$$

	6/30/2024	6/30/2025	6/30/2026
Total Debt	\$ 125,490,016	\$ 130,052,248	\$ 134,535,388
Population	66,216	67,715	69,500
Median Houshold Income	\$ 49,656	\$ 53,210	\$ 55,454
Debt as a Percentage of Personal Income	3.82%	3.61%	3.49%

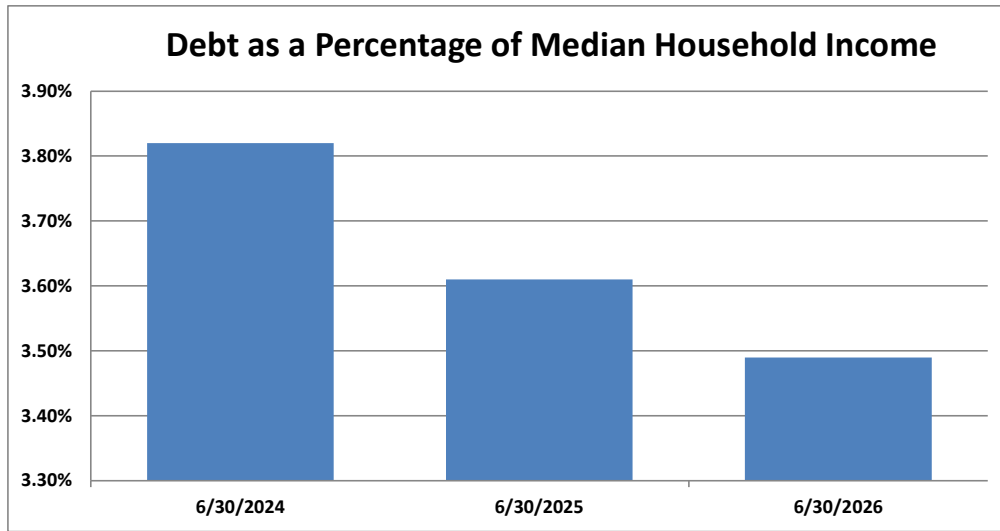

Debt as a Percentage of Personal Income - This ratio incorporates an ability to pay concept into the assessment of debt burden. It uses total personal income (including wages, dividends, interest, rent, and government payments) divided by total population. The lower the percentage the more desirable the measurement. A low debt per capita percentage indicates either a low debt burden or strong personal income or some combination of the two.

¹ Principal amount only (any interest expense that would be due is not included)

Hamblen County, Tennessee
Annual Debt Report
Net Debt as a Percentage of Median Household Income

Calculation Method:

$$\text{Net Debt as Percentage of Personal Income} = \frac{\text{Net Debt of the County}^1 / \text{County's Population}}{\text{Median Household Income}}$$

	Benchmark	Hamblen County
Total Debt		\$ 134,535,388
Less: Projected Year Fund Balance in the General Debt Service Fund		(14,222,822)
Net Debt		<u>\$ 120,312,566</u>
Median Household Income		<u>\$ 55,454</u>
Population		<u>69,500</u>
Net Debt as Percentage of Personal Income (not to exceed)	<u>4.50%</u>	<u>3.12%</u>

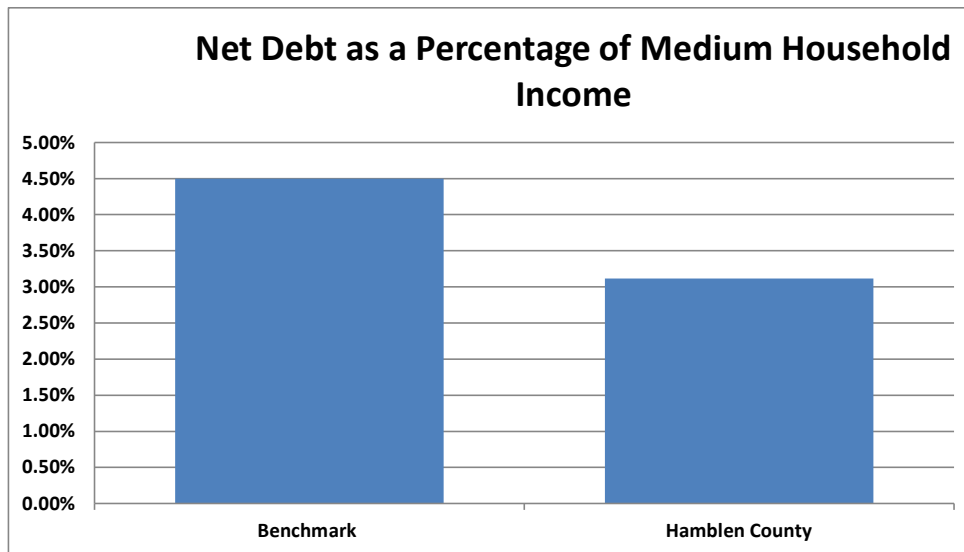

Net Debt as a Percentage of Personal Income - This ratio incorporates an ability to pay concept into the assessment of debt burden. It uses the medium household income (including wages, dividends, interest, rent, and government payments) divided by total population. This ratio can be utilized to determine how Hamblen County's debt load can be spread to its citizens based on their ability to pay. For comparison, a national standard uses a benchmark of not greater than 4.5% of total personal income to assess net debt. Hamblen County's current net debt as a percentage of personal income is 3.12%.

¹ Principal amount less projected year-end fund balance (any interest expense that would be due is not included)

Hamblen County, Tennessee
Annual Debt Report
Debt to Assessed Property Value

Calculation Method:

$$\text{Debt to Assessed Property Value} = \frac{\text{Total Debt of the County}^1}{\text{Assessed Property Value}}$$

	6/30/2024	6/30/2025	6/30/2026
Total Debt	\$ 125,490,016	\$ 130,052,248	\$ 134,535,388
Assessed Property Value	\$ 1,714,187,284	\$ 2,837,157,481	\$ 2,886,545,347
Debt to Assessed Property Value	7.32%	4.58%	4.66%

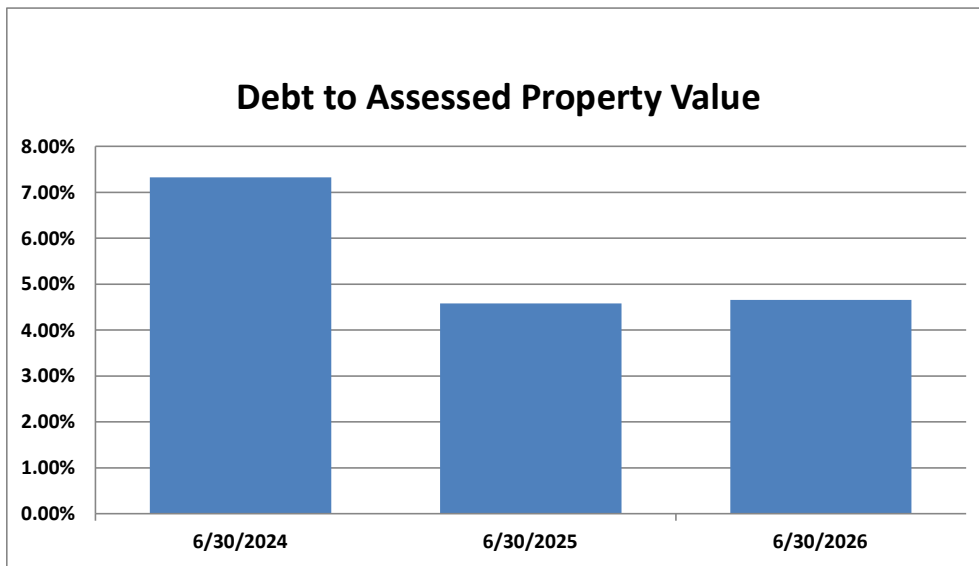

Debt to Assessed Property Value - This ratio examines Hamblen County's current indebtedness to assessed property value. It measures the wealth available to support present indebtedness so the County can include any anticipated debt to calculate a new ratio, thus helping determine whether the County has the capacity to meet present and future obligations.

¹ Principal amount only (any interest expense that would be due is not included)

Hamblen County, Tennessee
Annual Debt Report
Net Debt to Assessed Property Value

Calculation Method:

$$\frac{\text{Net Debt to Assessed Property Value}}{\text{Property Value}} = \frac{\text{Net Debt of the County}^1}{\text{Assessed Property Value}}$$

	Benchmark	Hamblen County
Total Debt		\$ 134,535,388
Less: Projected Year Fund Balance in the General Debt Service Fund		<u>(14,222,822)</u>
Net Debt		<u>\$ 120,312,566</u>
Assessed Property Value		<u>\$ 2,886,545,347</u>
Net Debt to Assessed Property Value (Average Not to Exceed)	<u>10%</u>	<u>4.17%</u>

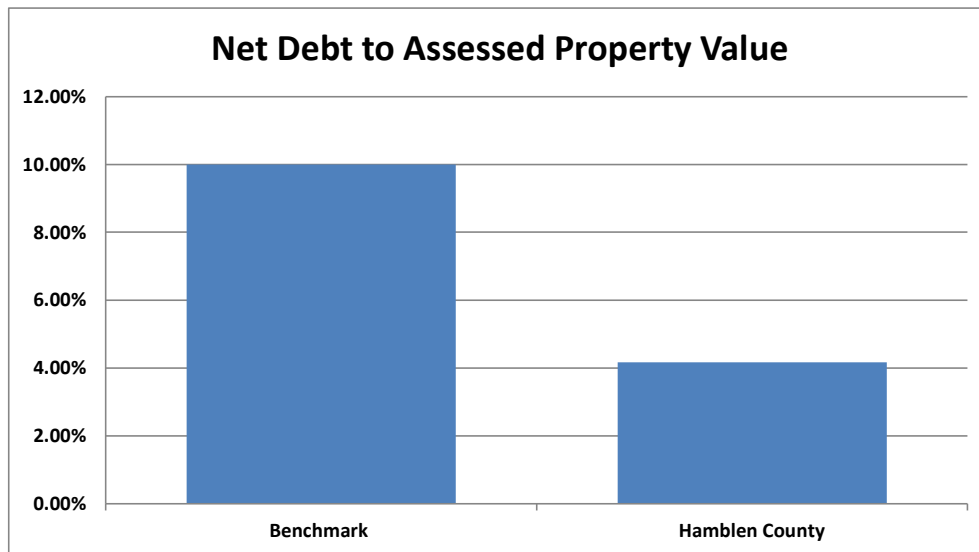

Net Debt to Assessed Property Value - This ratio examines Hamblen County's net indebtedness to the assessed property value. It measures the wealth available to support the County's current indebtedness and also helps the County evaluate its capacity to support any anticipated borrowing, thus helping determine whether the County has the capacity to meet increased debt obligations. The higher the percentage, the higher the tax rate must be in order to meet Hamblen County's obligation. The current benchmark being is 10%. Hamblen County's current net debt to assessed property value of 4.17% is well below the benchmark.

¹ Principal amount less projected year-end fund balance (any interest expense that would be due is not included)

Hamblen County, Tennessee
Annual Debt Report
Schedule of Long-term Debt Requirements by Year - Total
General Debt Service Fund

Year Ending June 30	Principal	Interest	Other Fees	Total
2027	5,453,342	5,455,287	2,820	10,911,449
2028	5,710,651	5,177,377	0	10,888,028
2029	5,849,726	4,897,536	0	10,747,262
2030	5,671,667	4,615,732	0	10,287,399
2031	5,660,000	4,340,432	0	10,000,432
2032	5,685,000	4,089,632	0	9,774,632
2033	5,705,000	3,841,182	0	9,546,182
2034	5,730,000	3,598,282	0	9,328,282
2035	5,760,000	3,353,464	0	9,113,464
2036	5,785,000	3,106,526	0	8,891,526
2037	5,815,000	2,862,039	0	8,677,039
2038	5,435,000	2,648,283	0	8,083,283
2039	5,450,000	2,449,726	0	7,899,726
2040	5,465,000	2,250,570	0	7,715,570
2041	5,485,000	2,049,895	0	7,534,895
2042	5,500,000	1,848,420	0	7,348,420
2043	5,520,000	1,646,000	0	7,166,000
2044	5,535,000	1,442,780	0	6,977,780
2045	4,860,000	1,238,960	0	6,098,960
2046	4,860,000	1,061,515	0	5,921,515
2047	4,360,000	882,979	0	5,242,979
2048	4,360,000	725,068	0	5,085,068
2049	4,360,000	567,156	0	4,927,156
2050	3,620,000	408,900	0	4,028,900
2051	3,620,000	270,050	0	3,890,050
2052	3,280,000	131,200	0	3,411,200
Total	\$ 134,535,386	\$ 64,958,992	\$ 2,820	\$ 199,497,198

Hamblen County, Tennessee
Annual Debt Report
Schedule of Long-term Debt Requirements by Year
Qualified School Construction Bond

Year Ending June 30	Principal	Interest	Other Fees	Total
2027	66,353	14,241	2,820	83,414
Total	\$ 66,353	\$ 14,241	\$ 2,820	\$ 83,414

NOTE:

The Qualified School Construction Bonds were issued through the Tennessee State School Bond Authority and loaned to Hamblen County on December 17, 2009, in the amount of \$11,280,000. This other loan was issued at a cost of \$124,936 for capital projects related to the school department. It is important to note that the Tennessee State School Bond Authority issued the bonds and loaned the proceeds to Hamblen County and various other governments across Tennessee. Hamblen County pays interest of 1.515 percent on its share of the bonds and also pays a monthly administrative fee to the State of Tennessee. Hamblen County and the other borrowers of the bond proceeds are required to comply with federal regulations established for the Qualified School Construction Bond program. Failure to comply with those requirements may result in the loss of the tax credit status of the bonds. This would result in further charges to the borrowers (Hamblen County) including the requirements to pay the tax-credit rate (5.86 percent) in addition to the 1.515 percent for a total rate of 7.375 percent. Currently, the budget is based on the 1.515 percent and the related monthly administrative fee.

Payments are made to the State of Tennessee and deposited into a sinking fund. The State holds the sinking fund payments in escrow and will pay off the full \$11,280,000 in 2027. This schedule reflects the remaining payments required to be made to the sinking fund.

Hamblen County, Tennessee
Annual Debt Report
Schedule of Long-term Debt Requirements by Year
USDA Rural Development Loan

Year Ending June 30	Principal	Interest	Total
2027	40,000	0	40,000
2028	40,000	0	40,000
2029	40,000	0	40,000
2030	36,667	0	36,667
Total	\$ 156,667	\$ 0	\$ 156,667

NOTE:

This is a USDA Rural Development Loan through Appalachian Electric Cooperative under a revolving loan program established pursuant to agreements with or through Rural Business - Cooperative Services Economic Development Loan and Grant Program.

Hamblen County, Tennessee
Annual Debt Report
Schedule of Long-term Debt Requirements by Year
General Obligation Bonds, Series 2020A

Year	Ending June 30	Principal	Interest	Total
2027		740,000	480,788	1,220,788
2028		740,000	443,788	1,183,788
2029		740,000	406,788	1,146,788
2030		740,000	369,787	1,109,787
2031		740,000	332,787	1,072,787
2032		740,000	317,987	1,057,987
2033		735,000	303,187	1,038,187
2034		735,000	288,487	1,023,487
2035		735,000	272,869	1,007,869
2036		735,000	256,331	991,331
2037		735,000	239,794	974,794
2038		735,000	222,338	957,338
2039		735,000	204,881	939,881
2040		735,000	187,425	922,425
2041		735,000	169,050	904,050
2042		735,000	150,675	885,675
2043		735,000	132,300	867,300
2044		735,000	113,925	848,925
2045		735,000	95,550	830,550
2046		735,000	77,175	812,175
2047		735,000	57,881	792,881
2048		735,000	38,588	773,588
2049		735,000	19,294	754,294
2050		0	0	0
2051		0	0	0
2052		0	0	0
Total		\$ 16,935,000	\$ 5,181,675	\$ 22,116,675

NOTE:

General Obligation Bonds, Series 2020A were issued on January 21, 2020 in the amount of \$19,995,000. These bonds were sold at premium totaling \$1,294,385. Direct costs of issuance totaled \$139,995, the underwriter's discount was \$220,730 (awarded to the lowest bidder), and bond insurance was \$43,400. These bonds were issued for improvements to West High School and for costs related to new jail construction. The fixed interest rates on the Series 2020 A bonds range from 2% percent to 5%.

Hamblen County, Tennessee
Annual Debt Report
Schedule of Long-term Debt Requirements by Year
General Obligation Bonds, Series 2021

Year	Ending June 30	Principal	Interest	Total
2027		345,000	219,195	564,195
2028		345,000	205,395	550,395
2029		345,000	191,595	536,595
2030		345,000	177,795	522,795
2031		345,000	163,995	508,995
2032		345,000	153,645	498,645
2033		345,000	146,745	491,745
2034		345,000	136,395	481,395
2035		345,000	126,045	471,045
2036		345,000	115,695	460,695
2037		345,000	108,795	453,795
2038		345,000	101,895	446,895
2039		345,000	94,995	439,995
2040		345,000	88,095	433,095
2041		345,000	81,195	426,195
2042		345,000	74,295	419,295
2043		345,000	67,050	412,050
2044		345,000	59,805	404,805
2045		345,000	52,560	397,560
2046		345,000	45,315	390,315
2047		345,000	37,898	382,898
2048		345,000	30,480	375,480
2049		345,000	23,062	368,062
2050		340,000	15,300	355,300
2051		340,000	7,650	347,650
2052		0	0	0
Total		<u>\$ 8,615,000</u>	<u>\$ 2,524,890</u>	<u>\$ 11,139,890</u>

NOTE:

General Obligation Bonds, Series 2021 were issued on December 17, 2021 in the amount of \$9,405,000. These bonds were sold at premium totaling \$593,681. Direct costs of issuance totaled \$102,043, the underwriter's discount was \$51,638 (awarded to the lowest bidder). These bonds were issued for costs related to new jail construction. The fixed interest rates on the Series 2021 bonds range from 2% percent to 4%.

Hamblen County, Tennessee
Annual Debt Report
Schedule of Long-term Debt Requirements by Year
General Obligation Bonds, Series 2022

Year	Ending June 30	Principal	Interest	Total
2027		3,280,000	3,741,450	7,021,450
2028		3,285,000	3,577,450	6,862,450
2029		3,285,000	3,413,200	6,698,200
2030		3,285,000	3,248,950	6,533,950
2031		3,285,000	3,084,700	6,369,700
2032		3,285,000	2,920,450	6,205,450
2033		3,285,000	2,756,200	6,041,200
2034		3,285,000	2,591,950	5,876,950
2035		3,285,000	2,427,700	5,712,700
2036		3,285,000	2,263,450	5,548,450
2037		3,280,000	2,099,200	5,379,200
2038		3,280,000	1,968,000	5,248,000
2039		3,280,000	1,836,800	5,116,800
2040		3,280,000	1,705,600	4,985,600
2041		3,280,000	1,574,400	4,854,400
2042		3,280,000	1,443,200	4,723,200
2043		3,280,000	1,312,000	4,592,000
2044		3,280,000	1,180,800	4,460,800
2045		3,280,000	1,049,600	4,329,600
2046		3,280,000	918,400	4,198,400
2047		3,280,000	787,200	4,067,200
2048		3,280,000	656,000	3,936,000
2049		3,280,000	524,800	3,804,800
2050		3,280,000	393,600	3,673,600
2051		3,280,000	262,400	3,542,400
2052		3,280,000	131,200	3,411,200
Total		<u>\$ 85,325,000</u>	<u>\$ 47,868,700</u>	<u>\$ 133,193,700</u>

NOTE:

General Obligation Bonds, Series 2022 were issued on May 13, 2022 in the amount of \$91,025,000. These bonds were sold at premium totaling \$7,689,933. Direct costs of issuance totaled \$495,708, the underwriter's discount was \$819,225 (awarded to the lowest bidder). These bonds were issued for construction of a new elementary school and for costs related to new jail construction. The fixed interest rates on the Series 2022 bonds range from 4% percent to 5%.

Hamblen County, Tennessee
Annual Debt Report
Schedule of Long-term Debt Requirements by Year
General Obligation Bonds, Series 2023

Year	Ending June 30	Principal	Interest	Total
	2027	260,000	150,950	410,950
	2028	270,000	137,950	407,950
	2029	285,000	124,450	409,450
	2030	300,000	110,200	410,200
	2031	310,000	98,200	408,200
	2032	325,000	85,800	410,800
	2033	335,000	72,800	407,800
	2034	350,000	59,400	409,400
	2035	365,000	45,400	410,400
	2036	375,000	30,800	405,800
	2037	395,000	15,800	410,800
	Total	<u>\$ 3,570,000</u>	<u>\$ 931,750</u>	<u>\$ 4,501,750</u>

NOTE:

General Obligation Bonds, Series 2023 were issued on February 10, 2023 in the amount of \$4,275,000. These bonds were sold at premium totaling \$322,966.65. Direct costs of issuance totaled \$69,195 and the underwriter's discount was \$26,564.44 (awarded to the lowest bidder). These bonds were issued on behalf of the Hamblen County-Morristown Waste Disposal System and will be treated as a loan to said organization. The Solid Waste System has committed to reimburse the County for interest and penalty payments per written agreement. The fixed interest rates on the Series 2023 bond range from 4% percent to 5%.

Hamblen County, Tennessee
Annual Debt Report
Schedule of Long-term Debt Requirements by Year
Capital Outlay Note, Series 2023 (Landfill Shredder)

Year	Ending June 30	Principal	Interest	Total
	2027	181,989	22,913	204,902
	2028	190,651	14,044	204,695
	2029	199,726	4,753	204,479
	Total	<u>\$ 572,366</u>	<u>\$ 41,711</u>	<u>\$ 614,077</u>

NOTE:

Capital Outlay Note, Series 2023 was issued on December 28, 2023 in the amount of \$900,000. Direct costs of issuance totaled \$11,515. This note was issued on behalf of the Hamblen County-Morristown Waste Disposal System and will be treated as a loan to said organization. The Solid Waste System has committed to reimburse the County for interest and penalty payments per written agreement. The fixed interest rate on the Series 2023 Capital Outlay Note is 4.760%.

Hamblen County, Tennessee
Annual Debt Report
Schedule of Long-term Debt Requirements by Year
General Obligation Bonds, Series 2024A (Landfill)

Year	Ending June 30	Principal	Interest	Total
2027		100,000	266,450	366,450
2028		250,000	261,450	511,450
2029		265,000	248,950	513,950
2030		275,000	235,700	510,700
2031		290,000	221,950	511,950
2032		305,000	207,450	512,450
2033		320,000	192,200	512,200
2034		330,000	179,400	509,400
2035		345,000	166,200	511,200
2036		360,000	152,400	512,400
2037		375,000	138,000	513,000
2038		390,000	123,000	513,000
2039		405,000	107,400	512,400
2040		420,000	91,200	511,200
2041		440,000	74,400	514,400
2042		455,000	56,800	511,800
2043		475,000	38,600	513,600
2044		490,000	19,600	509,600
Total		<u>\$ 6,290,000</u>	<u>\$ 2,781,150</u>	<u>\$ 9,071,150</u>

NOTE:

General Obligation Bonds, Series 2024A were issued on August 16, 2024 in the amount of \$6,290,000. These bonds were sold at premium totaling \$211,841.65. Direct costs of issuance totaled \$69,161.92 and the underwriter's discount was \$57,179.73 (awarded to the lowest bidder). These bonds were issued on behalf of the Hamblen County-Morristown Waste Disposal System and will be treated as a loan to said organization. The Solid Waste System has committed to reimburse the County for interest and penalty payments per written agreement. The fixed interest rates on the Series 2024A bond range from 4% percent to 5%.

Hamblen County, Tennessee
Annual Debt Report
Schedule of Long-term Debt Requirements by Year
General Obligation Bonds, Series 2024B (School - Walls)

Year	Ending June 30	Principal	Interest	Total
	2027	190,000	145,550	335,550
	2028	190,000	136,050	326,050
	2029	190,000	126,550	316,550
	2030	190,000	117,050	307,050
	2031	190,000	107,550	297,550
	2032	185,000	98,050	283,050
	2033	185,000	88,800	273,800
	2034	185,000	81,400	266,400
	2035	185,000	74,000	259,000
	2036	185,000	66,600	251,600
	2037	185,000	59,200	244,200
	2038	185,000	51,800	236,800
	2039	185,000	44,400	229,400
	2040	185,000	37,000	222,000
	2041	185,000	29,600	214,600
	2042	185,000	22,200	207,200
	2043	185,000	14,800	199,800
	2044	185,000	7,400	192,400
	Total	\$ 3,355,000	\$ 1,308,000	\$ 4,663,000

NOTE:

General Obligation Bonds, Series 2024B were issued on August 16, 2024 in the amount of \$3,355,000. These bonds were sold at premium totaling \$143,030.70. Direct costs of issuance totaled \$48,471.29 and the underwriter's discount was \$35,559.41 (awarded to the lowest bidder). These bonds were issued on behalf of the Hamblen County Board of Education for the enclosure of open classrooms at Lincoln and Meadowview Middle Schools. The fixed interest rates on the Series 2023 bond range from 4% percent to 5%.

Hamblen County, Tennessee
Annual Debt Report
Schedule of Long-term Debt Requirements by Year
General Obligation Bonds, Series 2025 (School - Walls)

Year	Ending June 30	Principal	Interest	Total
2027		250,000	413,750	663,750
2028		400,000	401,250	801,250
2029		500,000	381,250	881,250
2030		500,000	356,250	856,250
2031		500,000	331,250	831,250
2032		500,000	306,250	806,250
2033		500,000	281,250	781,250
2034		500,000	261,250	761,250
2035		500,000	241,250	741,250
2036		500,000	221,250	721,250
2037		500,000	201,250	701,250
2038		500,000	181,250	681,250
2039		500,000	161,250	661,250
2040		500,000	141,250	641,250
2041		500,000	121,250	621,250
2042		500,000	101,250	601,250
2043		500,000	81,250	581,250
2044		500,000	61,250	561,250
2045		500,000	41,250	541,250
2046		500,000	20,625	520,625
		<hr/>	<hr/>	<hr/>
Total		\$ 9,650,000	\$ 4,306,875	\$ 13,956,875

NOTE:

General Obligation Bonds, Series 2025 were issued on September 30, 2025 in the amount of \$9,650,000. These bonds were sold at premium totaling \$345,845. Direct costs of issuance totaled \$104,195 and the underwriter's discount was \$73,503.81 (awarded to the lowest bidder). These bonds were issued on behalf of the Hamblen County Board of Education for the enclosure of open classrooms at Lincoln and Meadowview Middle Schools and John Hay Elementary School. The fixed interest rates on the Series 2025 bond range from 4% percent to 5%.

Hamblen County Schedule of Total Payments

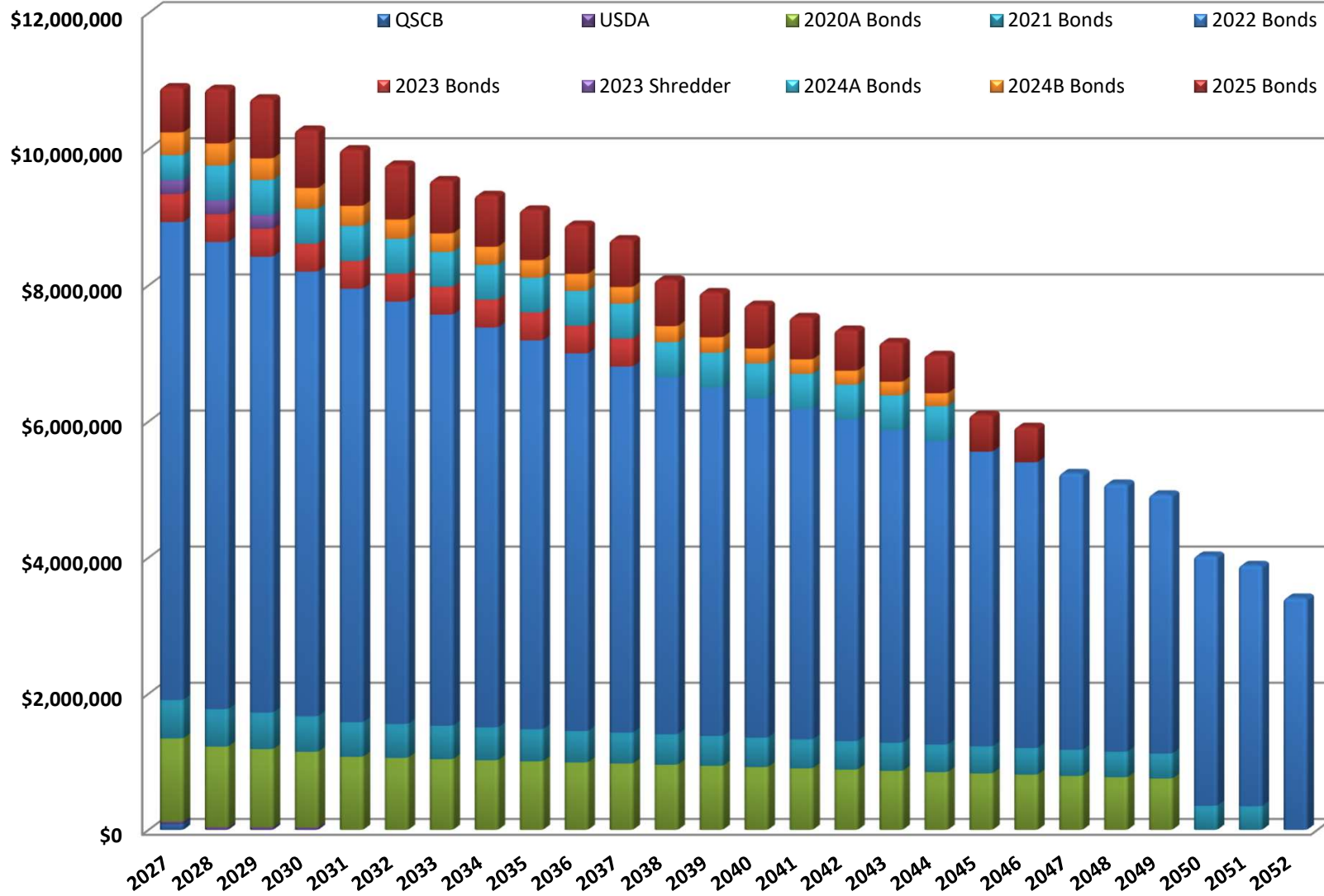

Hamblen County Schedule of Principal Payments

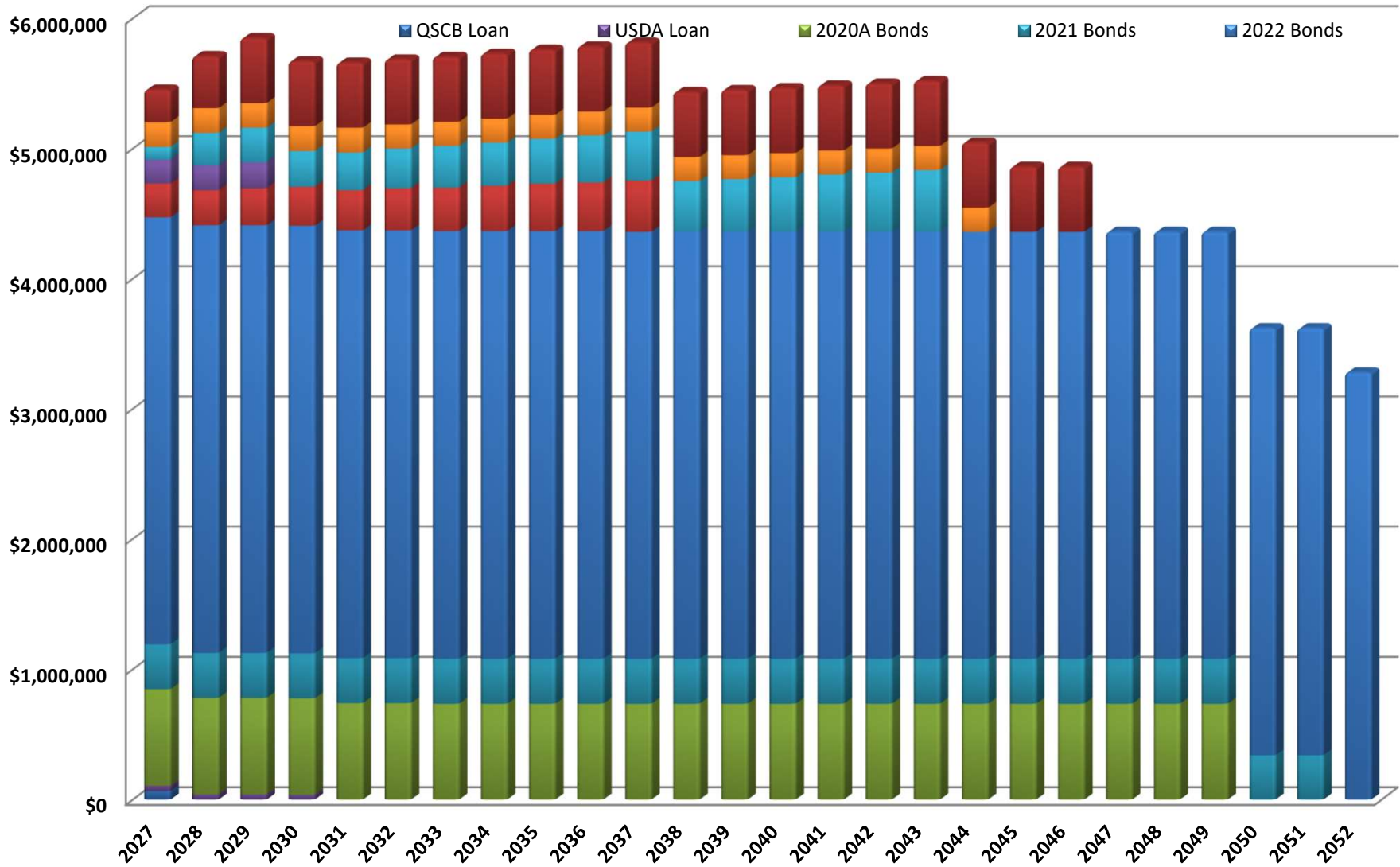

**Hamblen County
General Government to Schools Percentage
Total Outstanding Debt - \$134,535,388**

Percentage of Outstanding
Balance Related to Hamblen
County General Government
\$93,372,689
69.40%

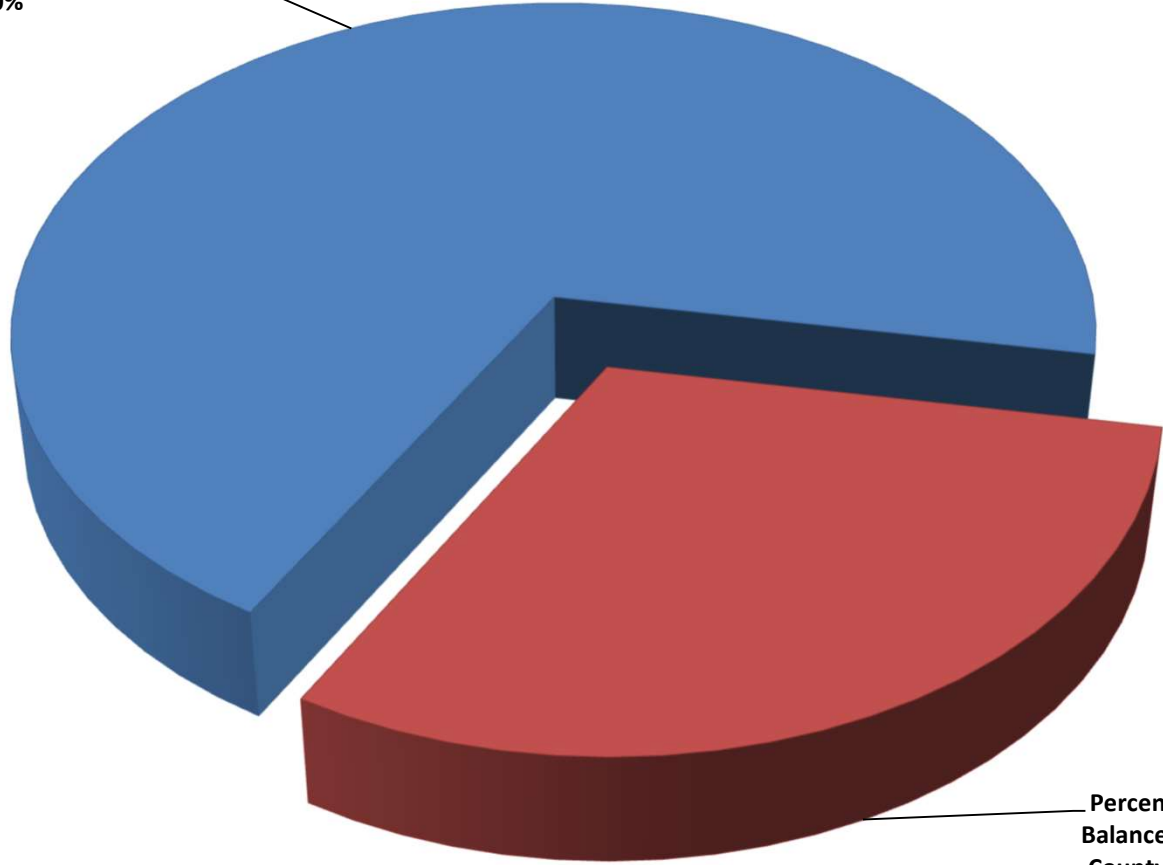

Percentage of Outstanding
Balance Related to Hamblen
County School Department
\$41,162,699
30.60%

Total Debt Per Capita - County Comparison

Data as of June 30, 2025 per Annual Financial Reports

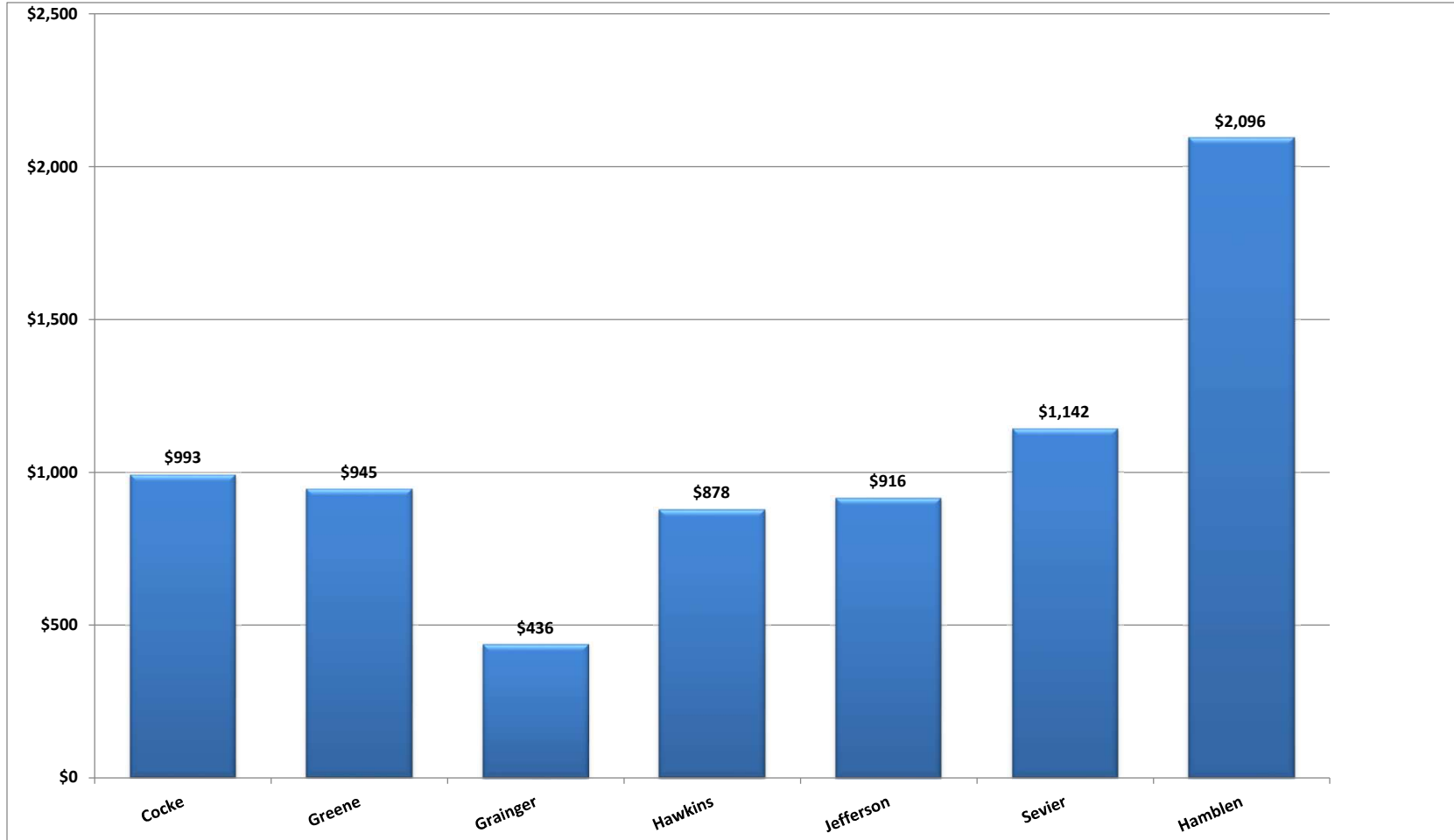

Hamblen County History of Total Debt

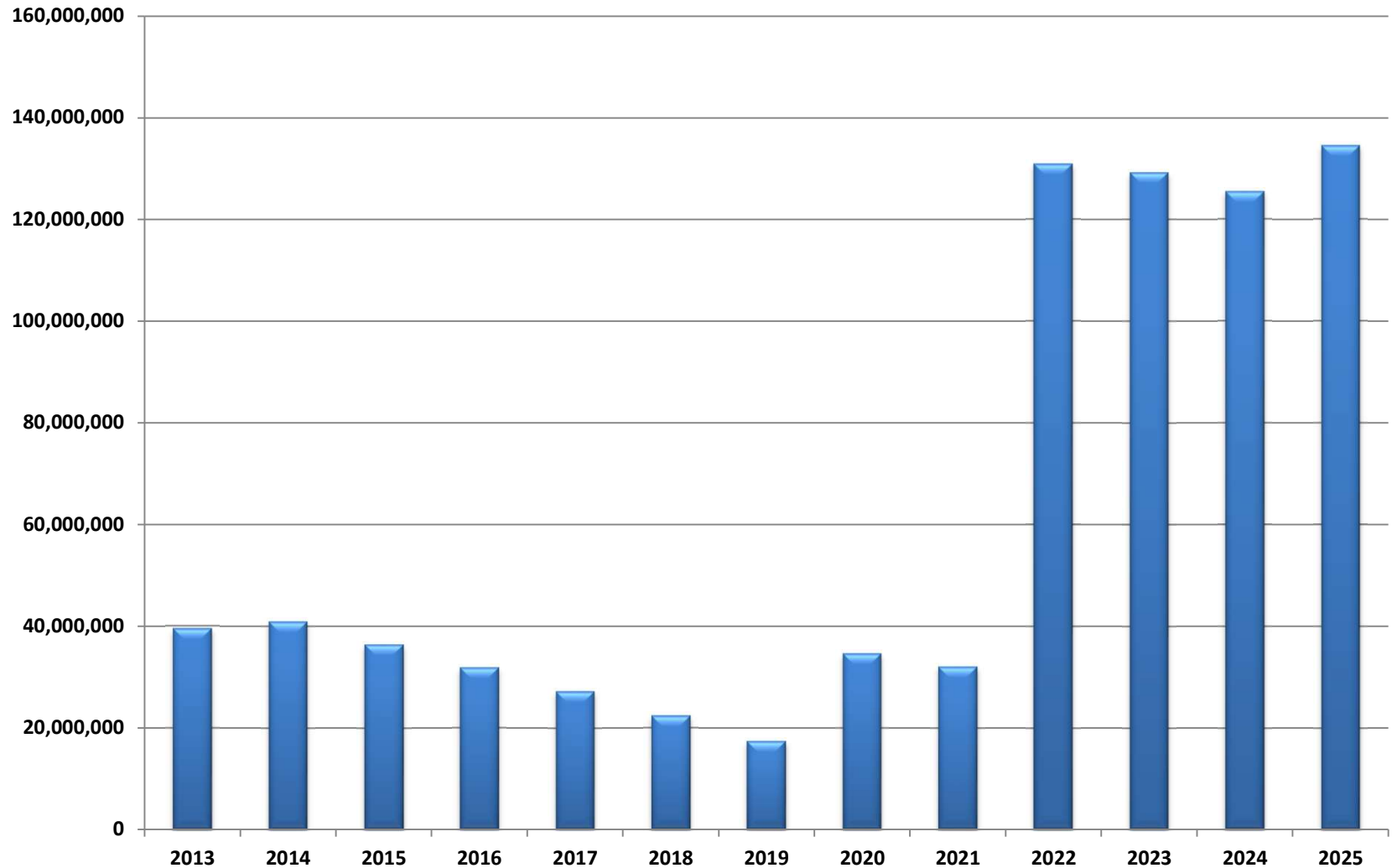

Hamblen County

Total Debt Payments Compared to Annual Revenue

- QSCB Loan
- USDA Loan
- 2020A (WHS&Jail)
- 2021 (Jail)
- 2022 (Linc&Jail)
- 2023 (SWB)
- 2023 Shredder
- 2024A (SWB)
- 2024B (HCBOE)
- 2025 (HCBOE)
- FY2026 Revenue

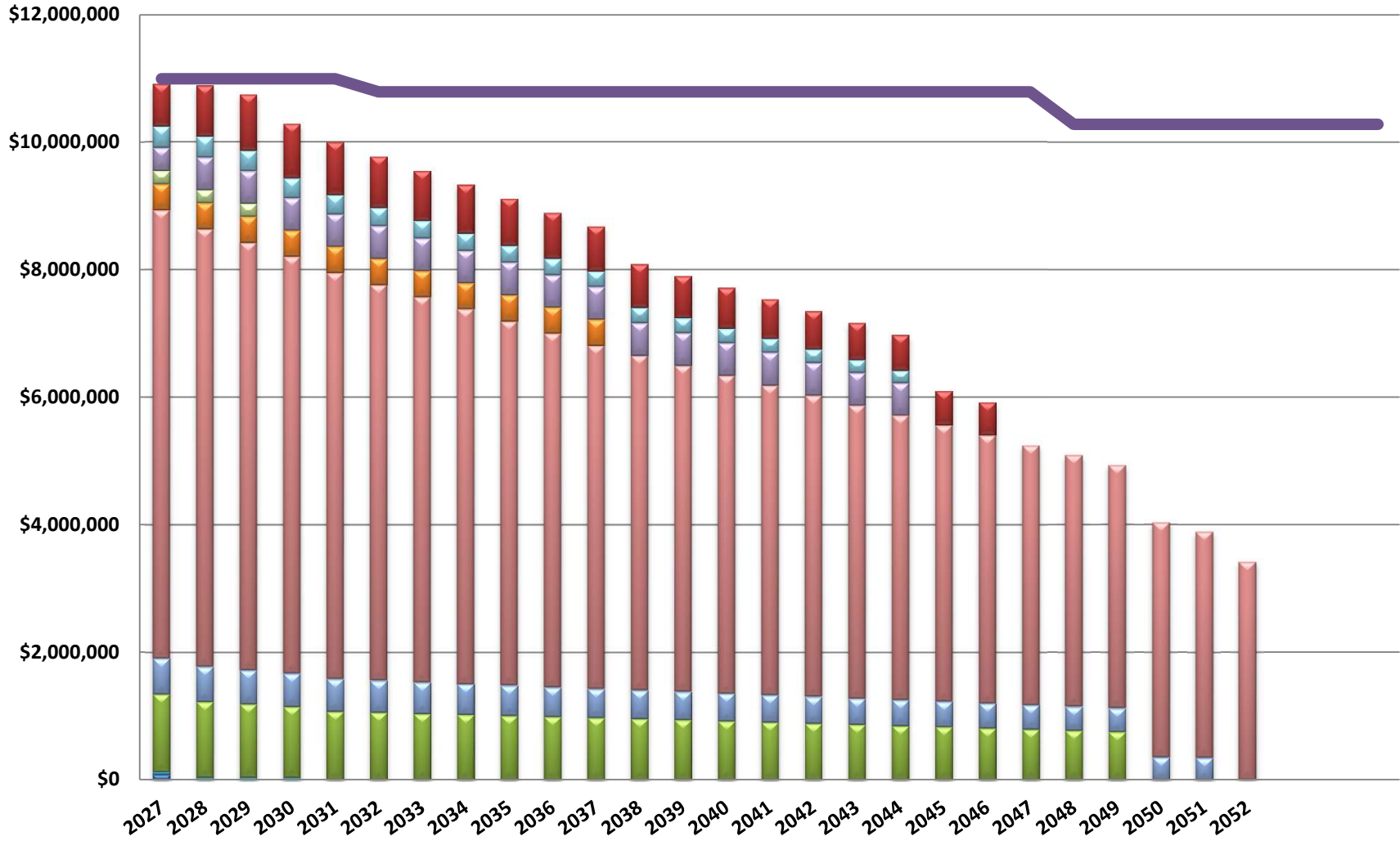



AIA® Document G714® – 2017

Construction Change Directive

PROJECT: *(name and address)*
Hamblen County Health Department

1578 Buffalo Trail
Morristown, TN 37814

CONTRACT INFORMATION:
Contract For:
General Construction - Base Bid
Date:
April 24, 2025

CCD INFORMATION:
Directive Number:
04 / BMA # 2207600
Date:
January 28, 2026

OWNER: *(name and address)*
Hamblen County Government
511 West Second North Street
Morristown, TN 37814

ARCHITECT: *(name and address)*
BarberMcMurry Architects LLC
505 Market Street, Suite 300
Knoxville, TN 37902

CONTRACTOR: *(name and address)*
Construction Partners, LLC
703 Princeton Road
Johnson City, TN 37601

The Contractor is hereby directed to make the following change(s) in this Contract:
(Insert a detailed description of the change and, if applicable, attach or reference specific exhibits.)

Repairs to foundation and slab at new exterior openings per response to RFI #13 (attached).

PROPOSED ADJUSTMENTS

1. The proposed basis of adjustment to the Contract Sum or Guaranteed Maximum Price is:

- Lump Sum increased by \$ 5,059.00
- Unit Price of \$ 0.00 per
- Cost, as defined below, plus the following fee: 0.00
(Insert a definition of, or method for determining, cost)

As follows:

2. The Contract Time will be unchanged by Zero (0) days.

NOTE: The Owner, Architect and Contractor should execute a Change Order to supersede this Construction Change Directive to the extent they agree upon adjustments to the Contract Sum, Contract Time, or Guaranteed Maximum price for the change(s) described herein.

When signed by the Owner and Architect and received by the Contractor, this document becomes effective IMMEDIATELY as a Construction Change Directive (CCD), and the Contractor shall proceed with the change(s) described above.

Contractor signature indicates agreement with the proposed adjustments in Contract Sum and Contract Time set forth in this CCD.

ARCHITECT *(Signature)*

BY: Charles V. Griffin, AIA, CEO
(Printed name, title, and license number if required)

28 January 2026
Date

OWNER *(Signature)*

(Printed name and title)

Date

CONTRACTOR *(Signature)*

(Printed name and title)

Date

CONSTRUCTION PARTNERS, LLC

COMMERCIAL, RETAIL & INDUSTRIAL CONTRACTING

RFI # 13

Request For Information

Date: December 2, 2025
To: Laura Johnston
Re: Hamblen County Health Department
Via: Email

1. At the new exterior openings there is CMU block that extends below the floor elevation, the drawings do not address this situation, please advise?

Thank you.

Travis Brooks

Below is a sketch of our recommendation on how to address this condition. Joele Fowler, B&P

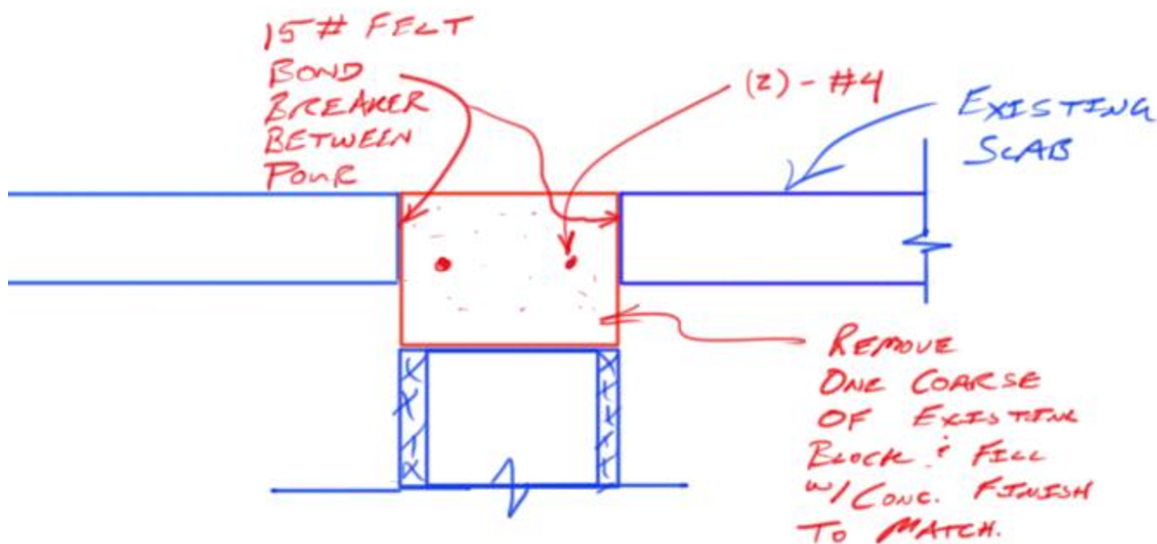



**BUDGET
AMENDMENTS**

**COMMISSION
APPROVAL**



HAMBLEN COUNTY DEPARTMENT OF EDUCATION

210 East Morris Boulevard
Morristown, Tennessee 37813
Phone (423) 586-7700 • Fax (423) 586-7747

The mission of Hamblen County Schools is to educate students so they can be challenged to successfully compete in their chosen fields.

ARNOLD W. BUNCH, JR.
Superintendent of Schools

AMENDMENT # 11 2025-2026

BOARD OF EDUCATION

- Carolyn Clawson
- Johnny Denton
- Bradley Harville
- Clyde Kinder
- Darlene Smith
- Jerrold Weems
- Robert Workman

The Hamblen County Board of Education requests approval from the Hamblen County Commission for Amendment #11 to the 2025-2026 General Purpose School Budget. Amendment #11 was approved by the Board of Education on June 9, 2026.

Initial Budget	\$ 120,034,856.06
Amendment 1	\$ 4,521,511.73
Amendment 2	\$ 375,724.61
Amendment 3	\$ 214,750.77
Amendment 4	\$ 4,972,416.00
Amendment 5	\$ 67,300.00
Amendment 6	\$ 47,286.00
Amendment 7	\$ 88,600.00
Amendment 8	\$ -
Amendment 9	\$ (230,043.92)
Amendment 10	\$ 2,562,500.21
Amendment 11	\$ 189,541.65
Total	\$ 132,844,443.11

This amendment does not affect the County's maintenance of effort.

Arnold W. Bunch, Jr., Superintendent of Schools

**HAMBLEEN COUNTY DEPARTMENT OF EDUCATION
2025-2026**

Arnold W. Bunch, Jr., Superintendent of Schools

**GENERAL FUND
AMENDMENT #11**

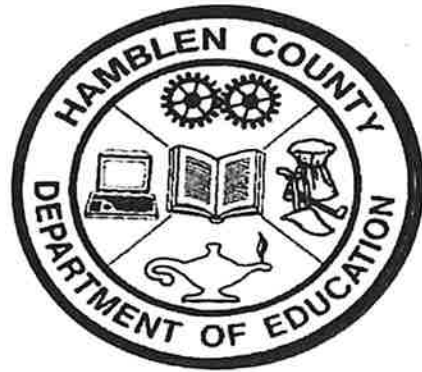

**HAMBLEN COUNTY SCHOOLS
GENERAL PURPOSE SCHOOL BUDGET
2025-2026**

AMENDMENT #11 - EXTERNAL

EXPENDITURE CODE	TITLE	BUDGET	INCREASE	DECREASE	ACTUAL	PURPOSE
71100-116-1446	TEACHERS	\$ 635,379.00	\$ 68,621.00	\$ -	\$ 704,000.00	JUNE 2026 SUMMER CAMP BUDGET
71100-201-1446	SOCIAL SECURITY	\$ 45,100.00	\$ 4,254.50	\$ -	\$ 49,354.50	
71100-204-1446	STATE RETIREMENT	\$ 65,465.00	\$ 6,175.89	\$ -	\$ 71,640.89	
71100-212-1446	EMPLOYER MEDICARE	\$ 10,550.00	\$ 995.00	\$ -	\$ 11,545.00	
71100-217-1446	RETIREMENT - HYBRID STABILIZATION	\$ 7,275.00	\$ -	\$ 235.00	\$ 7,040.00	
71100-499-1446	OTHER SUPPLIES AND MATERIALS	\$ 82,128.38	\$ -	\$ 69,640.56	\$ 12,487.82	
72710-599-1446	OTHER CHARGES	\$ 10,170.83	\$ -	\$ 10,170.83	\$ -	
71100-595	TISA - ON BEHALF PAYMENTS	\$ -	\$ 138,674.17	\$ -	\$ 138,674.17	TISA ON BEHALF - JDC & ACT - STATE MANDATED
71200-595	TISA - ON BEHALF PAYMENTS	\$ -	\$ 35,468.00	\$ -	\$ 35,468.00	TISA ON BEHALF - INDIVIDUALIZED EDUCATION ACCOUNT
72710-338	MAINTENANCE AND REPAIR SERVICE	\$ 29,000.00	\$ 5,191.90	\$ -	\$ 34,191.90	INSURANCE PROCEEDS FOR BUS REPAIRS
72710-453	VEHICLE PARTS	\$ 255,000.00	\$ 10,207.49	\$ -	\$ 265,207.49	
71200-163-1467	EDUCATIONAL ASSISTANTS	\$ 137,374.00	\$ -	\$ 75.00	\$ 137,299.00	RECLASS PRE-K GRANT FUNDS TO FULLY UTILIZE GRANT
71200-201-1467	SOCIAL SECURITY	\$ 8,518.00	\$ -	\$ 746.63	\$ 7,771.37	
71200-204-1467	STATE RETIREMENT	\$ 9,617.00	\$ -	\$ 10.99	\$ 9,606.01	
71200-206-1467	LIFE INSURANCE	\$ 255.00	\$ -	\$ 7.20	\$ 247.80	
71200-207-1467	MEDICAL INSURANCE	\$ 55,842.00	\$ -	\$ 10,468.29	\$ 45,373.71	
71200-212-1467	EMPLOYER MEDICARE	\$ 1,992.00	\$ -	\$ 174.47	\$ 1,817.53	
71200-499-1467	OTHER SUPPLIES AND MATERIALS	\$ 1,292.85	\$ 17,933.08	\$ -	\$ 19,225.93	
72220-204-1467	STATE RETIREMENT	\$ 450.00	\$ -	\$ 450.00	\$ -	
72220-212-1467	EMPLOYER MEDICARE	\$ 73.00	\$ -	\$ 0.50	\$ 72.50	
72220-399-1467	OTHER CONTRACTED SERVICES	\$ 6,000.00	\$ -	\$ 6,000.00	\$ -	
71300-116	TEACHERS	\$ 3,608,751.00	\$ -	\$ 2,500.00	\$ 3,606,251.00	YEAR END BUDGET TRUE-UP
71300-195	CERTIFIED SUBSTITUTE TEACHERS	\$ 69,372.00	\$ 1,000.00	\$ -	\$ 70,372.00	
71300-730	VOCATIONAL INSTRUCTION EQUIPME	\$ 11,282.00	\$ 1,500.00	\$ -	\$ 12,782.00	
72130-189	OTHER SALARIES AND WAGES	\$ 345,681.00	\$ -	\$ 15,000.00	\$ 330,681.00	
72130-322	EVALUATION AND TESTING	\$ 219,536.80	\$ 15,000.00	\$ -	\$ 234,536.80	
72220-124	PSYCHOLOGICAL PERSONNEL	\$ 317,243.00	\$ -	\$ 40,000.00	\$ 277,243.00	
72220-399	OTHER CONTRACTED SERVICES	\$ 500,460.00	\$ 40,000.00	\$ -	\$ 540,460.00	
72610-166	CUSTODIAL PERSONNEL	\$ 2,364,770.00	\$ -	\$ 80,000.00	\$ 2,284,770.00	
72610-207	MEDICAL INSURANCE	\$ 584,458.00	\$ -	\$ 40,000.00	\$ 544,458.00	
72610-399	OTHER CONTRACTED SERVICES	\$ 400,656.00	\$ 85,000.00	\$ -	\$ 485,656.00	
72610-415	ELECTRICITY	\$ 2,282,841.43	\$ 115,000.00	\$ -	\$ 2,397,841.43	
72610-454	WATER AND SEWER	\$ 588,000.00	\$ -	\$ 80,000.00	\$ 508,000.00	
TOTALS		\$ 12,654,513.29	\$ 645,021.03	\$ 355,479.47	\$ 12,844,054.85	
NET INCREASE			\$ 189,541.56			

**HAMBLEN COUNTY SCHOOLS
GENERAL PURPOSE SCHOOL BUDGET
2025-2026**

AMENDMENT #11 - EXTERNAL

REVENUE CODE	TITLE	BUDGET	INCREASE	DECREASE	ACTUAL	PURPOSE
46590-1446	OTHER STATE GRANTS	\$ 1,065,116.42	\$ 197,383.79	\$ -	\$ 1,262,500.21	JUNE 2026 SUMMER CAMP BUDGET
47590-1446	OTHER FEDERAL THROUGH THE STATE	\$ 197,383.79	\$ -	\$ 197,383.79	\$ -	
46513	TISA ON-BALHF PAYMENTS	\$ -	\$ 174,142.17	\$ -	\$ 174,142.17	TISA ON BEHALF - JDC, ACT, IEA - STATE MANDATED
46510	TISA	\$ 76,600,327.90	\$ -	\$ 39,758.00	\$ 76,560,569.90	
43542	CONTRACT FOR INSTRUCT SVCS OTHER LEA'S	\$ -	\$ 39,758.00	\$ -	\$ 39,758.00	
49700	INSURANCE RECOVERY	\$ 10,000.00	\$ 15,399.39	\$ -	\$ 25,399.39	INSURANCE PROCEEDS FOR BUS REPAIRS
TOTALS		\$ 77,872,828.11	\$ 426,683.35	\$ 237,141.79	\$ 78,062,389.67	
NET INCREASE			\$ 189,541.56			



Hamblen County Commission

For the June 2026 Commission Meeting

Account Number	Description	Increase	Decrease
Fund #101	DEPT: General Fund -Multiple Categories		
COUNTY COMMISSION			
101.51100.204	State Retirement	\$ 435.00	
101.51100.355	Travel	\$ 4,000.00	
101.51100.599	Other Charges	\$ 2,070.00	
101.51100.312	Contracts With Private Agencies		\$ 2,505.00
COUNTY MAYOR			
101.51300.103	Assistant(s)	\$ 6,400.00	
101.51300.201	Social Security	\$ 400.00	
101.51300.204	State Retirement	\$ 500.00	
101.51300.206	Life Insurance	\$ 15.00	
101.51300.212	Employer Medicare	\$ 100.00	
101.51300.317	Data Processing Services	\$ 20.00	
101.51300.320	Dues and Memberships	\$ 2,000.00	
101.51300.351	Rentals	\$ 300.00	
101.51300.355	Travel	\$ 1,100.00	
101.51300.599	Other Charges	\$ 5,000.00	
COUNTY ATTORNEY			
101.51400.331	Legal Services	\$ 61,000.00	
REGISTER OF DEEDS			
101.51600.206	Life Insurance	\$ 10.00	
101.51600.106	Deputy(ies)		\$ 10.00
PLANNING			
101.51720.312	Contracts With Private Agencies	\$ 4,000.00	
101.51720.101	County Official/Admin. Officer		\$ 4,000.00
CODES COMPLIANCE			
101.51750.207	Medical Insurance	\$ 2,000.00	
GEOGRAPHICAL INFORMATION SYSTEMS			
101.51760.309	Contracts With Government Agencies	\$ 4,000.00	
OTHER FACILITIES			
101.51810.105	Supervisor / Director	\$ 8,200.00	
101.51810.169	Part-Time Personnel	\$ 7,000.00	
101.51810.187	Overtime Pay	\$ 7,500.00	
101.51810.204	State Retirement	\$ 1,200.00	
101.51810.317	Data Processing Services	\$ 25.00	
101.51810.335	Maintenance and Repair Service - Buildings	\$ 30,000.00	
101.51810.347	Pest Control	\$ 500.00	
101.51810.410	Custodial Supplies	\$ 8,500.00	
101.51810.434	Natural Gas	\$ 92,000.00	
101.51810.166	Custodial Personnel		\$ 3,500.00
101.51810.167	Maintenance Personnel		\$ 2,000.00
101.51810.207	Medical Insurance		\$ 7,000.00
101.51810.307	Communication		\$ 12,000.00
101.51810.334	Maintenance Agreements		\$ 4,000.00
101.51810.415	Electricity		\$ 85,000.00



Hamblen County Commission

For the June 2026 Commission Meeting

Account Number	Description	Increase	Decrease
Fund	#101	DEPT:	General Fund -Multiple Categories
ACCOUNTING & BUDGETING			
101.52100.349	Printing, Stationery and Forms	\$ 1,500.00	
101.52100.435	Office Supplies	\$ 1,000.00	
101.52100.719	Office Equipment	\$ 4,000.00	
101.52100.207	Medical Insurance		\$ 6,500.00
PROPERTY ASSESSOR'S OFFICE			
101.52300.320	Dues and Memberships	\$ 1,000.00	
101.52300.348	Postal Charges	\$ 700.00	
101.52300.349	Printing, Stationery and Forms	\$ 550.00	
101.52300.309	Contracts with Government Agencies		\$ 1,200.00
101.52300.338	Maintenance and Repair Services - Vehicles		\$ 300.00
101.52300.425	Gasoline		\$ 500.00
101.52300.709	Data Processing Equipment		\$ 250.00
REAPPRAISAL PROGRAM			
101.52310.351	Rentals	\$ 300.00	
101.52310.399	Other Contracted Services		\$ 300.00
COUNTY TRUSTEE'S OFFICE			
101.52400.169	Part-Time Personnel	\$ 1,500.00	
101.52400.207	Medical Insurance	\$ 11,000.00	
101.52400.320	Dues and Memberships	\$ 50.00	
101.52400.508	Premiums on Corporate Surety Bonds		\$ 5,000.00
COUNTY CLERK'S OFFICE			
101.52500.317	Data Processing Services	\$ 300.00	
101.52500.348	Postal Charges	\$ 6,000.00	
101.52500.399	Other Contracted Services	\$ 1,000.00	
101.52500.106	Deputy(ies)		\$ 7,300.00
DATA PROCESSING			
101.52600.307	Communication	\$ 250.00	
101.52600.709	Data Processing Equipment	\$ 35,000.00	
101.52600.121	Data Processing Personnel		\$ 5,000.00
101.52600.207	Medical Insurance		\$ 4,000.00
101.52600.312	Contracts With Private Agencies		\$ 15,000.00
CIRCUIT COURT			
101.53100.332	Legal Notices, Recording and Court Costs	\$ 500.00	
101.53100.207	Medical Insurance		\$ 500.00
GENERAL SESSIONS COURT - COURT 1			
101.53300.186.00001	Longevity	\$ 3,150.00	
101.53300.207.00001	Medical Insurance	\$ 3,000.00	
101.53300.320.00001	Dues and Memberships	\$ 100.00	
101.53300.435.00001	Office Supplies	\$ 1,000.00	
101.53300.105.00001	Supervisor/Director		\$ 5,000.00
101.53300.189.00001	Other Salaries & Wages		\$ 2,250.00

Hamblen County Commission

For the June 2026 Commission Meeting

Account Number	Description	Increase	Decrease
Fund	#101	DEPT:	General Fund -Multiple Categories
GENERAL SESSIONS COURT - COURT 2			
101.53300.201.00002	Social Security	\$ 200.00	
101.53300.351.00002	Rentals	\$ 200.00	
101.53300.355.00002	Travel		\$ 400.00
DRUG COURT			
101.53330.368	Drug Treatment	\$ 200.00	
101.53330.425	Gasoline	\$ 1,000.00	
101.53330.435	Office Supplies	\$ 500.00	
101.53330.463	Testing	\$ 500.00	
101.53330.499	Other Supplies and Materials	\$ 1,200.00	
101.53330.207	Medical Insurance		\$ 3,400.00
CHANCERY COURT			
101.53400.169	Part-Time Personnel	\$ 12,000.00	
101.53400.307	Communication	\$ 600.00	
101.53400.348	Postal Charges	\$ 6,000.00	
101.53400.711	Furniture and Fixtures	\$ 2,500.00	
101.53400.106	Deputy(ies)		\$ 13,100.00
101.53400.207	Medical Insurance		\$ 8,000.00
JUVENILE COURT			
101.53500.204	State Retirement	\$ 450.00	
101.53500.186	Longevity	\$ 225.00	
101.53500.422	Food Supplies	\$ 500.00	
101.53500.164	Attendants		\$ 1,175.00
MENTAL HEALTH COURT			
101.53900.187	Overtime Pay	\$ 6,100.00	
101.53900.320	Dues and Memberships	\$ 200.00	
101.53900.355	Travel	\$ 4,400.00	
101.53900.399	Other Contracted Services	\$ 250.00	
101.53900.524	In Service / Staff Development	\$ 3,640.00	
101.53900.106	Deputy(ies)		\$ 10,590.00
101.53900.207	Medical Insurance		\$ 4,000.00
PROBATION SERVICES			
101.53910.162	Clerical Personnel	\$ 450.00	
101.53910.207	Medical Insurance	\$ 2,750.00	
101.53910.435	Office Supplies	\$ 1,000.00	
101.53910.169	Part-Time Personnel		\$ 4,200.00
COURTROOM SECURITY			
101.53920.169	Part-Time Personnel	\$ 29,000.00	
101.53920.187	Overtime Pay	\$ 6,400.00	
101.53920.451	Uniforms	\$ 3,700.00	
101.53920.106	Deputy(ies)		\$ 20,000.00
101.53920.207	Medical Insurance		\$ 10,000.00
101.53920.204	State Retirement		\$ 9,100.00



Hamblen County Commission

For the June 2026 Commission Meeting

Account Number	Description	Increase	Decrease
Fund	#101	DEPT: General Fund -Multiple Categories	
SHERIFF'S DEPARTMENT			
101.54110.140	Salary Supplements	\$ 15,000.00	
101.54110.162	Clerical Personnel	\$ 4,000.00	
101.54110.320	Dues and Memberships	\$ 2,000.00	
101.54110.338	Maintenance and Repair Services - Vehicles	\$ 27,000.00	
101.54110.399	Other Contracted Services	\$ 1,000.00	
101.54110.431	Law Enforcement Supplies	\$ 1,000.00	
101.54110.599	Other Charges	\$ 500.00	
101.54110.425	Gasoline		\$ 20,000.00
101.54110.450	Tires and Tubes		\$ 15,000.00
101.54110.207	Medical Insurance		\$ 10,000.00
101.54110.204	State Retirement		\$ 5,500.00
SPECIAL PATROLS - SRO'S			
101.54120.140	Salary Supplements	\$ 18,000.00	
101.54120.186	Longevity	\$ 2,000.00	
101.54120.187	Overtime Pay	\$ 10,000.00	
101.54120.204	State Retirement	\$ 11,000.00	
101.54120.334	Maintenance Agreements	\$ 7,000.00	
101.54120.355	Travel	\$ 33,000.00	
101.54120.451	Uniforms	\$ 7,000.00	
101.54120.524	In Service / Staff Development	\$ 10,000.00	
101.54120.599	Other Charges	\$ 3,000.00	
101.54120.716	Law Enforcement Equipment	\$ 285,000.00	
101.54120.207	Medical Insurance		\$ 20,000.00
JAIL			
101.54210.187	Overtime Pay	\$ 45,000.00	
101.54210.334	Maintenance Agreements	\$ 25,000.00	
101.54210.335	Maintenance and Repair Services - Buildings	\$ 7,000.00	
101.54210.340	Medical and Dental Services	\$ 150,000.00	
101.54210.441	Prisoners Clothing	\$ 2,500.00	
101.54210.599	Other Charges	\$ 12,000.00	
101.54210.716	Law Enforcement Equipment	\$ 12,000.00	
101.54210.160	Guards		\$ 253,500.00
WORK RELEASE PROGRAM			
101.54250.207	Medical Insurance	\$ 5,100.00	
101.54250.348	Postal Charges	\$ 500.00	
101.54250.435	Office Supplies	\$ 1,000.00	
101.54250.524	In Service / Staff Development		\$ 400.00
101.54250.338	Maintenance and Repair Services - Vehicles		\$ 1,900.00
CIVIL DEFENSE			
101.54410.103	Assistant(s)	\$ 1,000.00	
101.54410.105	Supervisor / Director	\$ 8,000.00	
101.54410.201	Social Security	\$ 200.00	
101.54410.204	State Retirement	\$ 200.00	
101.54410.207	Medical Insurance	\$ 6,500.00	
101.54410.212	Employer Medicare	\$ 26.00	
101.54410.307	Communication	\$ 500.00	
101.54410.425	Gasoline		\$ 500.00

[Return to Regular Calendar](#)



Hamblen County Commission

For the June 2026 Commission Meeting

Account Number	Description	Increase	Decrease
Fund #101	DEPT: General Fund -Multiple Categories		
OTHER EMERGENCY MANAGEMENT			
101.54490.316.0911	Contributions - E-911	\$ 10,872.00	
MEDICAL EXAMINER			
101.54610.307	Communication	\$ 3,000.00	
101.54610.399	Other Contracted Services	\$ 3,000.00	
101.54610.435	Office Supplies	\$ 1,500.00	
101.54610.341	Pauper Burials		\$ 4,500.00
101.54610.312	Contracts with Private Agencies		\$ 3,000.00
DRUG COURT EXPANSION - PUBLIC SAFETY GRANT			
101.54710.187	Overtime Pay	\$ 5,400.00	
101.54710.307	Communication	\$ 1,000.00	
101.54710.463	Testing	\$ 500.00	
101.54710.524	In Service / Staff Development	\$ 1,115.00	
101.54710.599	Other Charges	\$ 2,000.00	
101.54710.121	Data Processing Personnel		\$ 5,115.00
101.54710.207	Medical Insurance		\$ 4,900.00
LOCAL HEALTH CENTER			
101.55110.307	Communication	\$ 500.00	
101.55110.347	Pest Control	\$ 500.00	
101.55110.207	Medical Insurance		\$ 1,000.00
PARKS AND FAIR BOARDS			
101.56700.169	Part-Time Personnel	\$ 2,000.00	
101.56700.336	Maintenance & Repair Services - Equipment	\$ 6,000.00	
101.56700.410	Custodial Supplies	\$ 2,500.00	
101.56700.599	Other Charges	\$ 1,000.00	
101.56700.167	Maintenance Personnel		\$ 4,500.00
101.56700.415	Electricity		\$ 4,000.00
101.56700.454	Water and Sewer		\$ 3,000.00
OTHER SOCIAL, CULTURAL, & RECREATIONAL			
101.56900.312	Contracts with Private Agencies	\$ 8,500.00	
		Increase	
101.46980	Other State Grants - Increase from America 250 Grant	\$ 8,500.00	
STORM WATER MANAGEMENT			
101.57800.399	Other Contracted Services	\$ 5,500.00	
101.57800.355	Travel		\$ 1,000.00
TOURISM			
101.58110.399	Other Contracted Services	\$ 115,000.00	
		Increase	
101.43381	Tourism Fees - Increase in Revenue from Sponsorships	\$ 65,000.00	

Hamblen County Commission

For the June 2026 Commission Meeting

Account Number	Description	Increase	Decrease
Fund #101	DEPT: General Fund -Multiple Categories		
	OTHER ECONOMIC AND COMMUNITY DEVELOPMENT		
101.58190.421	Food Preparation Supplies	\$ 165,734.49	
		Increase	
101.47590	Other Federal through State - Food Insecurity Grant	\$ 165,734.49	
	MISCELLANEOUS		
101.58900.510	Trustee's Commission	\$ 170,000.00	
	MISCELLANEOUS		
101.58900.310	Contracts With Other Public Agencies	\$ 16,000.00	
		Increase	
101.47590	Other Federal through State - ETDD District Grant Admin Reimb	\$ 16,000.00	
	MISCELLANEOUS		
101.58900.312	Contracts with Private Agencies	\$ 90,000.00	
		Increase	
101.47590	Other Federal through State - Broadband Ready Grant Reimb	\$ 90,000.00	
	GENERAL ADMINISTRATION PROJECTS		
101.91110.707	Building Improvements	\$ 7,000.00	
101.91110.712	Heating & Air Conditioning Equipment	\$ 45,000.00	
101.91110.732	Building Purchases	\$ 670.00	
	PUBLIC SAFETY PROJECTS		
101.91130.718	Motor Vehicles	\$ 57,055.00	
		Increase	
101.46980	Other State Grants - Mental Health Transport Grant Reimb.	\$ 57,055.00	
	PUBLIC HEALTH AND WELFARE PROJECTS		
101.91140.304	Architects	\$ 138,000.00	
101.91140.707	Building Improvements	\$ 728,000.00	
101.91140.707.6500	Building Improvements	\$ 4,365,000.00	
101.91140.791	Other Construction	\$ 25,000.00	
101.91140.791.6500	Other Construction	\$ 178,000.00	
		Increase	
101.47590	Other Federal through State - TN Health Dept. Grant Reimb	\$ 4,322,500.00	
	EMPLOYEE BENEFITS		
101.58600.506	Liability Insurance		\$ 170,000.00
	DECREASE APPROPRIATIONS		
101.39000	Unassigned Fund Balance		\$ 1,762,828.00

2,126,692

2,547,723



Hamblen County Commission

For the June 2026 Commission Meeting _____

Account Number	Description		Increase	Decrease
Fund	#101	DEPT: General Fund -Multiple Categories		
<i>Brief Descriptions of issue:</i>				
This is a clean up budget amendment to attempt to ensure that lines and categories across accounts in the general fund remain within budget for FY 2025-2026.				

Signature: Amanda Hale
 Title : Finance Director
 Date: 6/12/24

<p><u>For Finance Department Only:</u> Reviewed by: _____ Budget Amendment: _____ Date: _____</p>
--



Hamblen County Commission

For the June 2026 Commission Meeting

Fund #116

DEPT: Solid Waste / Sanitation Fund

Account Number	Description	Increase	Decrease
INCREASE APPROPRIATIONS:			
116.55710.187	Overtime Pay	\$ 6,600.00	
116.55710.307	Communication	\$ 2,000.00	
116.55710.433	Lubricants	\$ 1,000.00	
116.55710.435	Office Supplies	\$ 500.00	
116.55710.499	Other Supplies and Materials	\$ 6,000.00	
116.55710.506	Liability Insurance	\$ 6,000.00	
116.55710.510	Trustee's Commission	\$ 15,000.00	
DECREASE APPROPRIATIONS:			
116.55710.412	Diesel Fuel		\$ 37,100.00
		37,100.00	37,100.00

Brief Descriptions of issue:
 To adjust budgeted amounts in the Sanitation Fund to cover expenses through EOY 26-27

Signature: Amanda Hale
 Title : Finance Director
 Date: 6/12/26

For Finance Department Only:
 Reviewed by: _____
 Budget Amendment: _____
 Date: _____



Hamblen County Commission

For the June 2026 Commission Meeting

Fund #128

DEPT: Drug Use Abatement Fund

Account Number	Description	Increase	Decrease
	INCREASE APPROPRIATIONS:		
128.55130.316	Ambulance/Emergency Medical Services	\$ 133,608.00	
128.55170.316	Alcohol & Drug Programs	\$ 175,880.00	
128.95900.000	Capital Projects Donated to Other Entities	\$ 10,800.76	
128.99100.590	Transfers Out	\$ 40,000.00	
	DECREASE APPROPRIATIONS:		
128.39000	Unassigned Fund Balance		\$ 360,288.76
		360,288.76	360,288.76

Brief Descriptions of issue:
 To increase appropriations to cover commission approved contributions to various non-profits in FY 25-26

Signature: Amanda Hale
 Title: Finance Director
 Date: 6/12/26

For Finance Department Only:
 Reviewed by: _____
 Budget Amendment: _____
 Date: _____



Hamblen County Commission

For the June 2026 Commission Meeting

Fund #131

DEPT: Highway Department Fund

Account Number	Description	Increase	Decrease
INCREASE APPROPRIATIONS:			
131.61000.119	Accountants/Bookkeepers	\$ 1,300.00	
131.61000.207	Medical Insurance	\$ 8,000.00	
131.61000.415	Electricity	\$ 12,000.00	
131.62000.187	Overtime Pay	\$ 3,000.00	
DECREASE APPROPRIATIONS:			
131.62000.207	Medical Insurance		\$ 24,300.00
		24,300.00	24,300.00

Brief Descriptions of issue:

To adjust budgeted amounts in the Highway Fund to cover expenses through EOY 26-27

Signature: Amanda Hale
 Title : Finance Director
 Date: 6/12/26

For Finance Department Only:

Reviewed by: _____
 Budget Amendment: _____
 Date: _____



TENNESSEE
Hamblen County
 SERVICE • COMMUNITY • INDUSTRY
 OFFICE OF THE MAYOR

Hamblen County Commission

For the June 2026 Commission Meeting

Fund #151

DEPT: General Debt Service Fund

Account Number	Description	Increase	Decrease
	INCREASE APPROPRIATIONS:		
151.82230.603	Interest on Bonds (Education)	\$ 277,000.00	
151.82330.699	Other Debt Service (Education)	\$ 5,000.00	
	DECREASE APPROPRIATIONS:		
151.39000	Unassigned Fund Balance		\$ 282,000.00
		282,000.00	282,000.00

Brief Descriptions of issue:
 To recognize debt service expenses on HCBOE bond issued during FY 25-26

Signature: Amaude Hale
 Title : Finance Director
 Date: 6/12/26

For Finance Department Only:
 Reviewed by: _____
 Budget Amendment: _____
 Date: _____



Hamblen County Commission

For the June 2026 Commission Meeting

Fund	#154
------	------

DEPT: Special Debt Service

Account Number	Description	Increase	Decrease
154.82210.603	Interest on Bonds	\$ 0.16	
154.82310.399	Other Contracted Services	\$ 1,800.00	
154.82310.399	Other Debt Service	\$ 150,000.00	
DECREASE APPROPRIATIONS:			
154.39000	Unassigned Fund Balance		\$ 151,800.16
		151,800	151,800

Brief Descriptions of issue:
 To recognize interest adjustment and arbitrage liability payment on Landfill Debt Service bonds

Signature: Amanda Hale
 Title: Finance Director
 Date: 6/12/26

For Finance Department Only:	
Reviewed by:	_____
Budget Amendment:	_____
Date:	_____



TENNESSEE
Hamblen County
 SERVICE • COMMUNITY • INDUSTRY
 OFFICE OF THE MAYOR

Hamblen County Commission

For the June 2026 Commission Meeting

Fund #176

DEPT: Highway Capital Projects Fund

Account Number	Description	Increase	Decrease
	INCREASE APPROPRIATIONS:		
176.91200.510	Trustee's Commission	\$ 20,000.00	
	DECREASE APPROPRIATIONS:		
176.39000	Unassigned Fund Balance		\$ 20,000.00
		20,000.00	20,000.00

Brief Descriptions of issue:
 To increase appropriations to recognize Trustee commission costs for FY 25-26

Signature: Amanda Hale
 Title : Finance Director
 Date: 6/12/26

For Finance Department Only:
 Reviewed by: _____
 Budget Amendment: _____
 Date: _____



AIA® Document G714® – 2017

Construction Change Directive

PROJECT: *(name and address)*
Hamblen County Health Department
1578 Buffalo Trail
Morristown, TN 37814

CONTRACT INFORMATION:
Contract For:
General Construction - Base Bid
Date:
April 24, 2025

CCD INFORMATION:
Directive Number:
08 / BMA # 2207600
Date:
June 12, 2026

OWNER: *(name and address)*
Hamblen County Government
511 West Second North Street
Morristown, TN 37814

ARCHITECT: *(name and address)*
BarberMcMurry Architects LLC
505 Market Street, Suite 300
Knoxville, TN 37902

CONTRACTOR: *(name and address)*
Construction Partners, LLC
703 Princeton Road
Johnson City, TN 37601

The Contractor is hereby directed to make the following change(s) in this Contract:
(Insert a detailed description of the change and, if applicable, attach or reference specific exhibits.)

Remove horizontal push bars from openings 118A and 118B and replace with Hager 12L pulls, mounted vertically, on both sides of the doors. Use a cover to hide holes left from the push bars.

PROPOSED ADJUSTMENTS

- The proposed basis of adjustment to the Contract Sum or Guaranteed Maximum Price is:
 - Lump Sum unchanged \$ 0.00
 - Unit Price of \$ 0.00 per
 - Cost, as defined below, plus the following fee: 0.00
(Insert a definition of, or method for determining, cost)
 - As follows: Contractor to submit an itemized breakdown of costs including invoices.

- The Contract Time will be unchanged by Zero (0) days.

NOTE: The Owner, Architect and Contractor should execute a Change Order to supersede this Construction Change Directive to the extent they agree upon adjustments to the Contract Sum, Contract Time, or Guaranteed Maximum price for the change(s) described herein.

When signed by the Owner and Architect and received by the Contractor, this document becomes effective IMMEDIATELY as a Construction Change Directive (CCD), and the Contractor shall proceed with the change(s) described above.

Contractor signature indicates agreement with the proposed adjustments in Contract Sum and Contract Time set forth in this CCD.



ARCHITECT *(Signature)*
BY: Charles V. Griffin, AIA, CEO
(Printed name, title, and license number if required)

OWNER *(Signature)*
(Printed name and title)

CONTRACTOR *(Signature)*
(Printed name and title)

12 June 2026

Date

Date

Date

May 2026

Permit	Date	Applicant	Type	Address	Construction	Permit	SW	Plumbing	Mech.	Gas	Total	Tax Map	Group	Parcel	
26-0182	5/4/26	Brian Messer	Cover/Deck	573 Andrew Circle	\$8,000.00	\$160.00					\$160.00	047O	B	013.00	
26-0183	5/4/26	Claude Key	Garage 30x50	7574 Lebanon Church Rd	\$36,299.00	\$375.00					\$375.00	046		012.09	
26-0184	5/4/26	STM Contracting	House	678 Ailshie Rd	\$369,000.00	\$1,073.00	\$100.00				\$1,173.00				
26-0185	5/4/26	Carla Balsh	Carport 16x20	5011 Buell Chapel Rd	\$29,000.00	\$25.00					\$25.00	058		060.00	
26-0186M	5/4/26	STM Contracting	Mechanical	678 Ailshie Rd					\$20.00		\$20.00				
26-0187	5/4/26	C. Greenlee	Pool	1807 Mineral Hills	\$5,500.00	\$50.00					\$50.00	049		023.20	
26-0188P	5/5/26	Keri Jefferson	Plumbing	5454 Long Creek				\$50.00			\$50.00				
26-0189	5/5/26	Wesley Courtney	DWMH	5958 Fall Creek Dock Rd	\$160,000.00	\$350.00					\$350.00	011		047.00	
26-0190P	5/5/26	Eduardo Zapote	Plumbing	2536 Lakeview Dr				\$20.00			\$20.00	025		002.00	
26-0191P	5/5/26	Noel Lopez/STM	Plumbing	678 Ailshie Rd				\$20.00			\$20.00	057		005.05	
26-0192	5/5/26	Jorge Castellanos	Carport	5690 Long Creek Rd	\$8,500.00	\$25.00					\$25.00	062		025.01	
26-0193	5/5/26	Brent Robertson	Gas	4112 Scarlett Dr						\$20.00	\$20.00	040G	A	058.00	
26-0194	5/6/26	Gerardo Huerto	Deck	4873 Fowler Dr							\$0.00	010L	A	016.00	
26-0195	5/7/26	Aire Care Holdings	HVAC	2303 Courtney Dr	\$12,356.00	\$20.00					\$20.00	037		025.00	
26-0196	5/7/26	Carlyle Construction	Garage 50 x 100	1280 Wooddale Rd	\$200,000.00	\$1,250.00					\$1,250.00	039		042.08	
26-0197	5/7/26	Tennessee Valley Vet	Addition/Remodel/Cover	5023 Old White Pine Rd	\$430,000.00	\$867.00					\$867.00	057		100.00	
26-0198M	5/7/26	Tennessee Valley Vet	Mechanical	5023 Old White Pine Rd					\$30.00		\$30.00	057		100.00	
26-0199P	5/7/26	Tennessee Valley Vet	Plumbing	5023 Old White Pine Rd				\$91.00			\$91.00	057		100.00	
26-0200	5/7/26	Randy Everhart Jr.	Carport	615 Carroll Rd	\$6,572.00	\$25.00					\$25.00	035		004.07	
26-0201	5/8/26	Christian Morales	House	2992 Clearview Rd	\$300,000.00	\$571.75	\$100.00				\$671.75	032		117.03	
26-0202M	5/8/26	Christian Morales	Mechanical	2992 Clearview Rd					\$10.00		\$10.00	032		117.03	
26-0203P	5/8/26	Christian Morales	Plumbing	2992 Clearview Rd				\$75.00			\$75.00	032		117.03	
26-0204	5/8/26	Jerry Harris	House	4480 Stapleton Rd	\$290,000.00	\$2,100.00	\$100.00				\$2,200.00	035		024.01	
26-0205M	5/8/26	Jerry Harris	Mechanical	4480 Stapleton Rd					\$20.00		\$20.00	035		024.01	
26-0206G	5/8/26	Ricky Trent	Gas	355 New Line Rd						\$20.00	\$20.00	041		027.00	
26-0207	5/11/26	Teresa Templin	Pool/Deck	04120 Dan Drive	\$8,000.00	\$98.00					\$98.00	017D	B	003.00	
26-0208	5/11/26	Alma Mercado	Cover 18x12	1626 Valley Home Rd	\$2,000.00	\$54.00					\$54.00	049		023.06	
26-0209	5/11/26	Heather Walker	Garage 14x24	5578 Byrd Rd	\$24,041.00	\$149.00					\$149.00	018		051.03	
26-0210	5/11/26	Carlyle Construction	House 1320 sq ft	1420 Wooddale Rd	\$250,000.00	\$803.00	\$100.00				\$903.00	039		042.07	
26-0211	5/11/26	Carlyle Construction	Mechanical	1420 Wooddale Rd					\$40.00		\$40.00	039		042.07	
26-0212	5/11/26	Carlyle Construction	Plumbing	1420 Wooddale Rd				\$95.00			\$95.00	039		042.07	
26-0213	5/12/26	Luz Narvaez	DWMH 28x52	2735 White Oak Grove	\$50,000.00	\$350.00					\$350.00	056		031.00	
26-0214P	5/13/26	Noel Lopez	Plumbing	1083 Little Mountain Rd				\$140.00			\$140.00	027		011.10	
26-0215G	5/13/26	Comfort Control	Gas	249 Shaver Drive	\$500.00	\$98.00				\$20.00	\$20.00	054B	G	019.00	
26-0216	5/14/26	Lori Price	Storage Bldg 10x12	7250 Cedar Hill Rd	\$3,500.00	\$0.00					\$0.00	047		002.00	
26-0217P	5/18/26	Noel De Jesus Lopez	Plumbing	827 Kidwell Ridge Rd				\$95.00			\$95.00	040		047.01	
26-0218	5/19/26	Jason Phillips	Deck/Cover	4843 Fowler Drive	\$50,000.00	\$253.75					\$253.75	010	A	018.00	
26-0219	5/20/26	Benjamin Smelcer	Garage 30x40	1516 River Path	\$24,000.00	\$300.00					\$300.00	063G	A	004.00	
26-0220	5/20/26	Melvin Greene	Deck/Cover	7184 Mountain Valley Rd	\$5,000.00	\$88.00					\$88.00	028		024.00	
26-0221	5/20/26	Melvin Greene	Deck/Cover	7196 Mountain Valley Rd	\$5,000.00	\$88.25					\$88.25	028		024.02	
26-0222	5/20/26	Michael Roper	Above-Gd Pool	1662 Jaybird Rd	\$4,000.00	\$50.00					\$50.00	018		102.01	
26-0223	5/21/26	Tim Livingston	House 2151 sf	1975 Turners Landing Rd	\$475,173.00	\$1,301.80	\$100.00				\$1,401.80	011D	A	093.00	
26-0224M	5/21/26	Tim Livingston	Mechanical	1975 Turners Landing Rd		\$20.00					\$20.00	011D	A	093.00	
26-0225	5/22/26	Tim & Jennifer Johnson	Inground pool 12x28	5331 Brights Pike	\$52,000.00	\$50.00					\$50.00	018B	C	007.00	
26-0226	5/22/26	Virgil English	Deck/Cover 12x24	3829 Shandee Lane	\$12,000.00	\$97.00					\$97.00	031L	A	023.00	
26-0227	5/22/26	Meredith Blanken	Storage Bldg 10x16	3570 Nelson School Rd	\$4,864.00	\$40.00					\$40.00	056		003.03	
26-0228	5/26/26	Donna Thompson	Inground Pool 14x24	6231 Lavern Circle	\$63,300.00	\$50.00					\$50.00	054F	B	007.00	
26-0229	5/26/26	Bryson Bryant	Garage 16x35	2541 Lakemont Circle	\$10,524.00	\$140.00					\$140.00	0111	E	017.00	
26-0230	5/27/26	Nathan Bales	Carport 30x30	1344 Three Springs Rd	\$1,350.00	\$25.00					\$25.00	011		078.05	
26-0231	5/27/26	Larry Woody	Additi3n 20x30	1521 Carroll Rd	\$75,000.00	\$300.00					\$300.00	035		017.02	
26-0232	5/28/26	Galindo Velasquez	Additi3n 20x20	4490 Chucky River Rd	\$9,000.00	\$200.00					\$200.00	052		013.02	
26-0233	5/28/26	Galindo Velasquez	Storage bldg 24x36	4490 Chucky River Rd	\$4,000.00	\$216.00					\$216.00	052		013.02	
26-0234	5/28/26	Nathan Vaughn	Deck 10x48	1221 Savannah Dr	\$34,000.00	\$120.00					\$120.00	035D	A	009.00	
26-0235P	5/29/26	Mark Redmond	Plumbing	2280 Kingswood Dr				\$85.00			\$85.00	043H	B	002.00	
26-0236	5/29/26	Andrew & Ashley Winstead	House 2218 sq ft	1132 Wentworth Square	\$280,800.00	\$1,304.00	\$100.00				\$1,404.00	035C	C	009.00	
26-0237M	5/29/26	Andrew & Ashley Winstead	Mechanical	1132 Wentworth Square					\$52.50		\$52.50	035C	C	009.00	
		Total		Total:	\$3,303,279.00	\$12,989.55	\$600.00	\$671.00	\$172.50	\$60.00	\$14,493.05				
Running Total:					\$24,304,025.26	\$97,154.80	\$5,690.00	\$6,047.00	\$1,570.00	\$51,925.04	\$158,001.84				
					Total No.	Amount		Total					ETHRA	Monthly	YTD
				CHO and Miscellaneous	12	\$60.00		\$60.00				HOMES	0	0	
				Re-Zoning Request				\$0.00	Grand		\$15,972.05				
				Variance Request	5	\$250.00		\$250.00	Total:						
				Plat Approval	7	\$1,169.00		\$1,169.00							
		3 lots or more		Land Disturbance/Development				\$0.00							
				Use on Review				\$0.00	2025-2026						
				Refunds		\$0.00		\$0.00	Running						
				Total Collected		\$14,468.55		\$1,479.00	Total:	\$166,221.84					
				Running Total Collected				\$8,220.00							

LAW OFFICES
CAPPS & BYRD LLP
1004 WEST FIRST NORTH STREET
MORRISTOWN, TENNESSEE 37814

PAUL R. CAPPS (1922-2003)
FRANK P. CANTWELL JR (Ret.)

CHRISTOPHER P. CAPPS
DAVID S. BYRD



TELEPHONE: (423) 586-3083
FACSIMILE: (423) 586-0513
WEBSITE: cappsbyrdlaw.com
E-MAIL: info@cccblaw.com

June 3, 2026

Mr. Chris Cutshaw, County Mayor
Hamblen County Courthouse
511 West Second North Street
Morristown, TN 37814

**RE: INVOICES FOR LEGAL SERVICES RENDERED ON BEHALF
OF HAMBLLEN COUNTY, TENNESSEE - MAY, 2026**

Dear Chris:

Please find enclosed two (2) invoices representing legal services rendered on behalf of Hamblen County, Tennessee during the month of May, 2026.

As usual, one invoice covers our General/Miscellaneous File, and one (1) invoice covers a separate county department.

Please review these invoices, and if you have any questions, please do not hesitate to contact me.

With best regards, I remain,

Very truly yours,

A handwritten signature in blue ink that reads "Christopher P. Capps/alg". The signature is written in a cursive, flowing style.

Christopher P. Capps

CPC/alg

Enclosures

Capps & Byrd, LLP

1004 W. 1st North Street
Morristown, TN 37814

INVOICE

Invoice # 1346
Date: 06/03/2026
Due On: 07/03/2026

Hamblen County Government
Hamblen County Courthouse
511 West Second North Street
Morristown, TN 37814

00027-Hamblen County Government

General Account

Type	Date	Description	Quantity	Rate	Total
Service	05/01/2026	E-mails from Edna Greene re: sign and itemization for pending litigation/public records; e-mails from Wayne NeSmith and Edna Greene re: MOU with city and county; e-mail from John Dollarhide re: pending litigation	0.20	\$175.00	\$35.00
Service	05/04/2026	Phone conference with Bill Brittain; e-mails with Linda Noe and Matt Gerdeman re: pending litigation; e-mails with Trish Bowman re: public records request	0.40	\$175.00	\$70.00
Service	05/05/2026	E-mails with Linda Noe, Matt Gerdeman, Sharee Long and Jonathan Taylor re: pending litigation	0.40	\$175.00	\$70.00
Service	05/06/2026	E-mail to Edna Greene re: itemization for pending litigation; e-mails with Dennis Fox re: fireworks; e-mail from Gavin Smelcer re: pending litigation	0.25	\$175.00	\$43.75
Service	05/07/2026	E-mail to Trish Bowman re: pending litigation; e-mail from Trish Bowman re: 5/11 committee meeting	0.10	\$175.00	\$17.50
Service	05/08/2026	E-mail from Trish Bowman re: 5/11 committee meeting; e-mails with Jonathan Taylor re: pending litigation	0.10	\$175.00	\$17.50
Service	05/11/2026	E-mail to Linda Noe re: pending litigation	0.05	\$175.00	\$8.75
Service	05/12/2026	E-mails with Linda Noe and Melyssa McCracken re: pending litigation	0.15	\$175.00	\$26.25
Service	05/13/2026	E-mail from Edna Greene re: MOU with city and county; e-mail to Linda Noe re: pending litigation	0.10	\$175.00	\$17.50
Service	05/14/2026	E-mails from and to Linda Noe re: pending litigation; e-mail from Edna Greene re: landfill	0.15	\$175.00	\$26.25

Service	05/15/2026	E-mail from Linda Noe re: pending litigation	0.05	\$175.00	\$8.75
Service	05/18/2026	E-mail from Sue Budd re: pending litigation; e-mail David Purkey re: pending litigation	0.10	\$175.00	\$17.50
Service	05/19/2026	Phone conferences with Trish Bowman, Bill Brittain and Chris Cutshaw; e-mail from Trish Bowman re: 5/21 commission meeting; e-mails with David Purkey re: pending litigation; work on pending litigation	2.25	\$175.00	\$393.75
Service	05/20/2026	Phone conference with Trish Bowman; e-mail from Sandy Jenkins re: pending litigation; worked on pending litigation; e-mail to Linda Noe and Courtney Read re: pending litigation	1.25	\$175.00	\$218.75
Service	05/21/2026	E-mails with Courtney Read, Sharee Long, Sue Budd and Matt Gerdeman re: pending litigation; phone conferences with Bill Brittain and Chris Cutshaw	0.40	\$175.00	\$70.00
Service	05/26/2026	E-mails with Sue Budd and Linda Noe re: pending litigation	0.15	\$175.00	\$26.25
Service	05/27/2026	Conference with Bill Brittain and Chris Cutshaw; conference with Sheriff; e-mails to Jordan Lanius re: pending litigation	1.00	\$175.00	\$175.00
Service	05/28/2026	Prepare for hearing; hearing; prepare Order	4.75	\$175.00	\$831.25
Service	05/29/2026	E-mails with Jordan Lanius re: pending litigation; revise Order	0.25	\$175.00	\$43.75
				Total	\$2,117.50

Detailed Statement of Account

Current Invoice

Invoice Number	Due On	Amount Due	Payments Received	Balance Due	
1346	07/03/2026	\$2,117.50	\$0.00	\$2,117.50	
				Outstanding Balance	\$2,117.50
				Amount in Trust	\$0.00
				Total Amount Outstanding	\$2,117.50

Please make all amounts payable to: Capps & Byrd, LLP

Please pay within 30 days.

Capps & Byrd, LLP

1004 W. 1st North Street
Morristown, TN 37814

INVOICE

Invoice # 1343
Date: 06/02/2026
Due On: 07/02/2026

Hamblen County Government
Hamblen County Courthouse
511 West Second North Street
Morristown, TN 37814

00068-Hamblen County Planning Department

Planning

Type	Date	Description	Quantity	Rate	Total
Service	03/16/2026	E-mail from Donna Massey re: property	0.05	\$175.00	\$8.75
Service	05/05/2026	E-mail from Tommy McKinney re: property	0.05	\$175.00	\$8.75
Service	05/18/2026	E-mail to Kristy Brown	0.05	\$175.00	\$8.75
Service	05/21/2026	Phone conferences with Tommy McKinney and Edgar Gray	0.15	\$175.00	\$26.25
Service	05/22/2026	Phone conference with Tommy McKinney	0.10	\$175.00	\$17.50
Service	05/26/2026	Research; phone conferences with Tommy McKinney and Edgar Gray	0.50	\$175.00	\$87.50
Service	05/27/2026	Phone conferences with Tommy McKinney, Edgar Gray and Chris Cutshaw	0.25	\$175.00	\$43.75
				Total	\$201.25

Detailed Statement of Account

Current Invoice

Invoice Number	Due On	Amount Due	Payments Received	Balance Due
1343	07/02/2026	\$201.25	\$0.00	\$201.25
			Outstanding Balance	\$201.25
			Amount in Trust	\$0.00

Total Amount Outstanding **\$201.25**

Please make all amounts payable to: Capps & Byrd, LLP

Please pay within 30 days.



Financial Summary Report

Hamblen County Trustee
 Printed 06/04/2026 02:10 PM By SCOTTY LONG

Financial Summary Report - May 01, 2026 to May 31, 2026

Fund	Name	Starting Balance	Receipts	Disbursements	Transfers In	Transfers Out	Comm. Adj.	Commission	Ending Balance
101	GENERAL FUND	\$20,035,360.48	\$3,963,874.98	\$2,902,729.71	\$465,793.91	\$0.00	(\$8.32)	\$21,386.58	\$21,540,921.40
116	GARBAGE/SOLID WASTE	\$4,411,780.83	\$240,115.89	\$261,687.11	\$0.00	\$0.00	(\$1.73)	\$2,636.42	\$4,387,574.92
122	DRUG CONTROL	\$353,616.78	\$13,161.09	\$389.24	\$0.00	\$0.00	\$0.00	\$106.98	\$366,281.65
126	SCHOOL EMPLOYEE SELF INSURANCE	\$12,500.84	\$0.00	\$5,189.17	\$2,551.67	\$0.00	\$0.00	\$0.00	\$9,863.34
127	SCHOOL TAX ACCOUNT	\$480.88	\$2,055.54	\$2,409.73	\$0.00	\$0.00	\$0.00	\$0.00	\$126.69
128	OPIOID SETTLEMENT FUND	\$2,176,891.20	\$6,016.10	\$0.00	\$0.00	\$0.00	\$0.00	\$0.00	\$2,182,907.30
131	HIGHWAY/PUBLIC WORKS	\$2,015,155.91	\$456,291.70	\$168,869.40	\$0.00	\$0.00	\$0.00	\$2,058.08	\$2,300,520.13
141	GENERAL PURPOSE SCHOOL	\$36,605,346.54	\$4,643,068.51	\$9,462,057.16	\$0.00	\$0.00	(\$4.41)	\$24,901.18	\$31,761,461.12
142	SCHOOL FEDERAL PROJECTS	\$1,992,775.63	\$211,076.20	\$662,788.56	\$0.00	\$0.00	\$0.00	\$0.00	\$1,541,063.27
143	FOOD SERVICE	\$8,768,151.92	\$1,010,655.26	\$490,929.37	\$0.00	\$0.00	\$0.00	\$0.00	\$9,287,877.81
151	GENERAL DEBT SERVICE	\$14,932,653.93	\$481,897.17	\$1,891,546.25	\$0.00	\$0.00	(\$3.97)	\$3,903.02	\$13,519,105.80
154	SPECIAL DEBT SERVICE	\$3,321,210.34	\$9,841.10	\$474,747.31	\$0.00	\$0.00	\$0.00	\$0.00	\$2,856,304.13
171	GENERAL CAPITAL PROJECTS	\$217,327.66	\$0.00	\$17,700.00	\$0.00	\$0.00	\$0.00	\$0.00	\$199,627.66
176	HIGHWAY CAPITAL PROJECTS	\$4,377,058.04	\$297,060.86	\$8,573.27	\$0.00	\$0.00	\$0.00	\$2,970.61	\$4,662,575.02
178	AMERICAN RESCUE FUNDS	\$3,566,310.63	\$7,564.24	\$728,445.64	(\$1,765,793.91)	\$0.00	\$0.00	\$0.00	\$1,079,635.32
189	OTHER CAPITAL PROJECTS	\$10,906,570.94	\$29,651.62	\$973,673.18	\$0.00	\$0.00	\$0.00	\$0.00	\$9,962,549.38
263	EMPLOYEE SELF-INSURANCE	\$2,489,109.41	\$430,066.34	\$349,622.37	\$0.00	\$0.00	\$0.00	\$0.00	\$2,569,553.38
320	FLEX MEDICAL SPENDING	\$9,107.80	\$3,779.71	\$3,779.71	\$0.00	\$0.00	\$0.00	\$0.00	\$9,107.80
351	TRUST AND AGENCY	\$0.00	\$1,814,993.90	\$1,796,843.96	\$0.00	\$0.00	\$0.00	\$18,149.94	\$0.00
999	TRUSTEE'S OFFICE	(\$15,366,233.31)	(\$76,094.38)	\$0.00	\$0.00	\$0.00	\$0.00	\$0.00	(\$15,442,327.69)
22200	OVERFLOW	\$3,848.83	\$4,191.93	\$4,175.51	\$0.00	\$0.00	\$0.00	\$0.00	\$3,865.25
28310	UNDISTRIBUTED TAXES	\$176.00	\$0.00	\$0.00	\$0.00	(\$347.00)	\$0.00	\$0.00	\$523.00
29900	FEE/COMMISSION	\$15,367,933.31	\$76,112.81	\$0.00	\$0.00	\$18.43	\$0.00	\$0.00	\$15,444,027.69
		\$116,197,134.59	\$13,625,380.57	\$20,206,156.65	(\$1,297,448.33)	(\$328.57)	(\$18.43)	\$76,112.81	\$108,243,144.37



Financial Summary Report

Hamblen County Trustee

Printed 06/04/2026 02:10 PM By SCOTTY LONG

<i>Property Tax Summary</i>	<i>Summary of Assets Beginning Balances</i>	<i>Starting</i>	<i>Debits</i>	<i>Credits</i>	<i>Summary of Assets Ending Balances</i>
CURRENT YEAR	INVESTMENT ACCOUNTS	\$0.00	\$0.00(+)	\$0.00(-)	\$0.00
PRIOR YEAR	CASH	\$1,700.00	\$2,334,695.36(+)	\$2,334,695.36(-)	\$1,700.00
BANKRUPTCY	BANK ACCOUNTS	\$116,190,341.60	\$46,839,819.18(+)	\$54,792,005.40(-)	\$108,238,155.38
INTEREST	COMPENSATION ACCOUNT	\$0.00	\$0.00(+)	\$0.00(-)	\$0.00
	STATE TAX RELIEF	\$2,685.00	\$240.00(+)	\$2,044.00(-)	\$881.00
	UNUSED ACCOUNTS	\$0.00	\$0.00(+)	\$0.00(-)	\$0.00
	TOTAL	116194726.6	\$49,174,754.54	\$57,128,744.76	\$108,240,736.38

This report is submitted in accordance with requirements of section 5-8-505 and 67-5-1902 Tennessee Code, annotated and to the best of my knowledge and belief, accurately reflects transactions of this office May 01, 2026 through May 31, 2026

Signature: 

Title: TRUSTEE

June 04, 2026

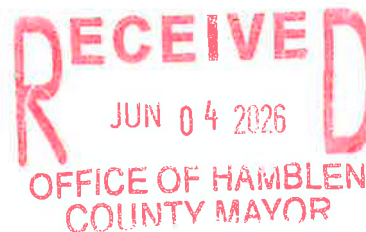

MORRISTOWN-HAMBLENS EMS

Board of Directors Meeting Minutes

Date: April 22, 2026

Time: 1200

Location: MHEMS Central Station, North Auditorium

Attendance

Voting Members	Ex-Officio Members
Ralph Williams, Chairman	Danny Houseright, Director
Jimmy Peoples	Claude Thompson, Deputy Director
Stan Harville	Tim Meridith
Brian Shepard	Jackie Livesay, Medical Director
Clyde Short	
Joe Senter	
Bruce Fowler	
Barry Jarnigan	
Sonya Johnson	

Call to Order

Meeting called to order by Chairman Ralph Williams at 1206.

No public comment

Approval of Previous Meeting Minutes

March meeting minutes approved. Motion by Stan Harville, second by Barry Jarnigan.

Ratification of meeting minutes from 3-28-26. Motion by Stan Harville, second by Joe Senter.

Financial Report

Financial report presented by Tim Meridith. See attached report.

Motion to approve by Stan Harville. Second by Joe Senter.

Rescue Squad Report

No representation from Rescue Squad. Director Houseright discussed death of Bucky Long a longtime Rescue Squad member and EMA SAR training.

Director's Report

Claude Thompson has been promoted to Deputy Director.

Clyde Short voiced his displeasure of timing of the promotion.

Chairman Ralph Williams advised the board to remember they are an advisement board and not in control of day-to-day operations.

EMS Week 2026 planned for week of May 16.

New Air medical service (Covenant Air) discussion. This will provide better access to our patients and additional resources in our service area.

Grant discussion for vents and video scopes. Grant was compiled, submitted, and approved in accordance with Tennessee EMS Board requirements. Employees will be trained on new equipment ASAP.

MHEMS employees were nominated for Star of Life Award presented by Dolly Parton Childrens Hospital. Board members are welcomed to attend banquet on May 16.

Adjournment

Meeting adjourned. 1238

Submitted By:



**Claude Thompson
Deputy Director, Morristown-Hamblen EMS**

**HAMBLLEN COUNTY DEPARTMENT OF EDUCATION
QUARTERLY EXPENDITURE REPORT**

Arnold W. Bunch, Jr., Superintendent of Schools

**THIRD QUARTER
2025-2026**

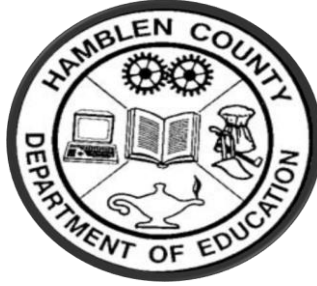

**THE COUNTY BOARD OF EDUCATION REPORTS THE FOLLOWING REVENUE
FOR THE PUBLIC SCHOOL PURPOSE AS OF THE QUARTER ENDING MARCH 31, 2026**

GENERAL PURPOSE	BUDGET	COLLECTED	UNCOLLECTED REVENUE	PERCENT UNCOLLECTED
LOCAL REVENUES	\$ 27,956,092.00	\$ 24,020,840.19	\$ 3,935,251.81	14.08%
CHARGES FOR CURRENT SERVICES	807,000.00	778,702.34	28,297.66	3.51%
OTHER LOCAL REVENUES	614,916.60	432,854.94	182,061.66	29.61%
STATE REVENUES	87,008,708.54	67,413,762.04	19,594,946.50	22.52%
OTHER STATE REVENUES	2,896,260.27	216,239.34	2,680,020.93	92.53%
FEDERAL REVENUES	103,325.00	66,497.39	36,827.61	35.64%
OTHER SOURCES	1,605,839.92	67,976.67	1,537,863.25	95.77%
TOTALS	\$ 120,992,142.33	\$ 92,996,872.91	\$ 27,995,269.42	23.14%

**THE COUNTY BOARD OF EDUCATION REPORTS THE FOLLOWING EXPENDITURES
FOR THE PUBLIC SCHOOL PURPOSE AS OF THE QUARTER ENDING MARCH 31, 2026**

GENERAL PURPOSE	BUDGET	SPENT	REMAINING	PERCENT REMAINING
REGULAR INSTRUCTION	\$ 59,181,299.31	\$ 38,705,430.08	\$ 20,475,869.23	34.60%
SPECIAL EDUCATION	9,828,175.57	6,634,364.52	3,193,811.05	32.50%
VOCATIONAL EDUCATION	6,262,617.97	3,654,590.69	2,608,027.28	41.64%
STUDENT BODY	188,000.00	157,804.78	30,195.22	16.06%
ATTENDANCE	4,789.00	2,656.52	2,132.48	44.53%
HEALTH SERVICES	1,292,764.11	835,450.27	457,313.84	35.37%
OTHER STUDENT SUPPORT	3,250,780.33	2,122,628.95	1,128,151.38	34.70%
INSTRUCTIONAL ADMINISTRATION	4,091,362.25	2,287,270.95	1,804,091.30	44.10%
SPECIAL EDUCATION ADMINISTRATION	1,559,431.49	900,592.35	658,839.14	42.25%
VOCATIONAL EDUCATION ADMINISTRATION	513,576.75	340,394.05	173,182.70	33.72%
TECHNOLOGY	2,639,527.64	2,056,892.60	582,635.04	22.07%
BOARD OF EDUCATION	2,157,381.91	1,827,128.56	330,253.35	15.31%
OFFICE OF THE DIRECTOR	857,233.09	569,859.06	287,374.03	33.52%
OFFICE OF THE PRINCIPAL	6,536,518.33	4,337,362.48	2,199,155.85	33.64%
FISCAL SERVICES	788,796.68	503,112.66	285,684.02	36.22%
HUMAN SERVICES/PERSONNEL	304,416.27	200,748.95	103,667.32	34.05%
OPERATION OF PLANT	7,500,351.33	5,192,146.59	2,308,204.74	30.77%
MAINTENANCE OF PLANT	2,204,091.18	1,596,962.40	607,128.78	27.55%
TRANSPORTATION	4,341,206.16	2,934,332.61	1,406,873.55	32.41%
EXTENDED SCHOOL PROGRAM/FAM. RESOURCE	696,048.94	492,472.75	203,576.19	29.25%
EARLY CHILDHOOD EDUCATION	1,714,099.22	1,153,079.06	561,020.16	32.73%
REGULAR CAPITAL OUTLAY	13,881,733.64	6,456,097.77	7,425,635.87	53.49%
EDUCATION DEBT SERVICE	500,000.00	500,000.00	-	0.00%
TRANSFERS	28,244.00	-	28,244.00	100.00%
TOTALS	\$ 130,322,445.17	\$ 83,461,378.65	\$ 46,861,066.52	35.96%

**THE COUNTY BOARD OF EDUCATION REPORTS THE FOLLOWING EXPENDITURES
FOR THE PUBLIC SCHOOL PURPOSE AS OF THE QUARTER ENDING MARCH 31, 2026**

FEDERAL PROGRAMS - CONSOLIDATED ADMIN.	BUDGET	EXPENDED	REMAINING	PERCENT REMAINING
REGULAR INSTRUCTION	\$ 191,685.00	\$ 140,154.19	\$ 51,530.81	26.88%
TOTALS	\$ 191,685.00	\$ 140,154.19	\$ 51,530.81	26.88%

FEDERAL PROGRAMS - TITLE I	BUDGET	EXPENDED	REMAINING	PERCENT REMAINING
REGULAR INSTRUCTION	\$ 2,173,172.86	\$ 1,699,678.42	\$ 473,494.44	21.79%
OTHER STUDENT SUPPORT	125,778.28	29,402.70	96,375.58	76.62%
REGULAR INSTRUCTION	1,099,129.00	371,976.82	727,152.18	66.16%
TRANSPORTATION	20,000.00	3,068.13	16,931.87	84.66%
TRANSFERS	91,695.36	-	91,695.36	100.00%
TOTALS	\$ 3,509,775.50	\$ 2,104,126.07	\$ 1,405,649.43	40.05%

FEDERAL PROGRAMS - ATSI GRANT	BUDGET	EXPENDED	REMAINING	PERCENT REMAINING
REGULAR INSTRUCTION	\$ 5,565.00	\$ 5,316.27	\$ 248.73	4.47%
REGULAR INSTRUCTION	94,435.00	75,868.78	18,566.22	19.66%
TOTALS	\$ 100,000.00	\$ 81,185.05	\$ 18,814.95	18.81%

FEDERAL PROGRAMS - TITLE IIA	BUDGET	EXPENDED	REMAINING	PERCENT REMAINING
REGULAR INSTRUCTION	\$ 925,872.25	\$ 252,818.03	\$ 673,054.22	72.69%
TRANSFERS	24,000.00	-	24,000.00	100.00%
TOTALS	\$ 949,872.25	\$ 252,818.03	\$ 697,054.22	73.38%

FEDERAL PROGRAMS - TITLE III	BUDGET	EXPENDED	REMAINING	PERCENT REMAINING
REGULAR INSTRUCTION	\$ 189,193.00	\$ 71,366.55	\$ 117,826.45	62.28%
OTHER STUDENT SUPPORT	36,879.00	23,301.20	13,577.80	36.82%
REGULAR INSTRUCTION	110,495.00	36,803.58	73,691.42	66.69%
TRANSFERS	500.00	-	500.00	100.00%
TOTALS	\$ 337,067.00	\$ 131,471.33	\$ 205,595.67	61.00%

**THE COUNTY BOARD OF EDUCATION REPORTS THE FOLLOWING EXPENDITURES
FOR THE PUBLIC SCHOOL PURPOSE AS OF THE QUARTER ENDING MARCH 31, 2026**

FEDERAL PROGRAMS - TITLE IV	BUDGET	EXPENDED	REMAINING	PERCENT REMAINING
REGULAR INSTRUCTION	\$ 98,760.07	\$ 42,240.13	56,519.94	57.23%
HEALTH SERVICES	188,169.00	120,613.31	67,555.69	35.90%
REGULAR INSTRUCTION	2,000.00	216.50	1,783.50	89.18%
TRANSFERS	<u>2,500.00</u>	<u>-</u>	<u>2,500.00</u>	<u>100.00%</u>
TOTALS	<u>\$ 291,429.07</u>	<u>\$ 163,069.94</u>	<u>\$ 128,359.13</u>	<u>44.04%</u>

FEDERAL PROGRAMS - TITLE IX HOMELESS ED.	BUDGET	EXPENDED	REMAINING	PERCENT REMAINING
REGULAR INSTRUCTION	\$ 155,298.91	\$ 74,728.86	\$ 80,570.05	51.88%
REGULAR INSTRUCTION	4,500.00	3,602.85	897.15	19.94%
TRANSPORTATION	<u>5,000.00</u>	<u>1,668.08</u>	<u>3,331.92</u>	<u>66.64%</u>
TOTALS	<u>\$ 164,798.91</u>	<u>\$ 79,999.79</u>	<u>\$ 84,799.12</u>	<u>51.46%</u>

FEDERAL PROGRAMS - CARL PERKINS	BUDGET	EXPENDED	REMAINING	PERCENT REMAINING
VOCATIONAL EDUCATION	\$ 149,836.46	\$ 116,997.28	\$ 32,839.18	21.92%
OTHER STUDENT SUPPORT	37,936.56	24,795.32	13,141.24	34.64%
VOCATIONAL EDUCATION	4,000.00	2,925.79	1,074.21	26.86%
TRANSPORTATION	23,717.75	13,147.24	10,570.51	44.57%
TRANSFERS	<u>823.35</u>	<u>-</u>	<u>823.35</u>	<u>100.00%</u>
TOTALS	<u>\$ 216,314.12</u>	<u>\$ 157,865.63</u>	<u>\$ 58,448.49</u>	<u>27.02%</u>

FEDERAL PROGRAMS - IDEA	BUDGET	EXPENDED	REMAINING	PERCENT REMAINING
SPECIAL EDUCATION	\$ 2,123,924.38	\$ 1,447,905.36	\$ 676,019.02	31.83%
SPECIAL EDUCATION	212,287.44	158,745.41	53,542.03	25.22%
TRANSFERS	<u>1,105,839.92</u>	<u>-</u>	<u>1,105,839.92</u>	<u>0.00%</u>
TOTALS	<u>\$ 3,442,051.74</u>	<u>\$ 1,606,650.77</u>	<u>\$ 1,835,400.97</u>	<u>53.32%</u>

**THE COUNTY BOARD OF EDUCATION REPORTS THE FOLLOWING EXPENDITURES
FOR THE PUBLIC SCHOOL PURPOSE AS OF THE QUARTER ENDING MARCH 31, 2026**

FEDERAL PROGRAMS - SPED PRESCHOOL	BUDGET	EXPENDED	REMAINING	PERCENT REMAINING
SPECIAL EDUCATION	\$ 106,238.05	\$ 59,256.72	\$ 46,981.33	44.22%
SPECIAL EDUCATION	-	-	-	0.00%
TOTALS	\$ 106,238.05	\$ 59,256.72	\$ 46,981.33	44.22%

FEDERAL PROGRAMS - ESSER 3.0	BUDGET	EXPENDED	REMAINING	PERCENT REMAINING
REGULAR INSTRUCTION	\$ -	\$ 107.65	\$ (107.65)	0.00%
REGULAR CAPITAL OUTLAY	19,856.77	19,856.77	-	0.00%
TOTALS	\$ 19,856.77	\$ 19,964.42	\$ (107.65)	-0.54%

FEDERAL PROGRAMS - LITERACY MATERIALS GRANT	BUDGET	EXPENDED	REMAINING	PERCENT REMAINING
REGULAR INSTRUCTION	\$ 10,000.00	\$ -	\$ 10,000.00	100.00%
REGULAR INSTRUCTION	80,000.00	-	80,000.00	100.00%
TOTALS	\$ 90,000.00	\$ -	\$ 90,000.00	100.00%

FEDERAL PGMS. - CTE TEC PATHWAYS GRANT	BUDGET	EXPENDED	REMAINING	PERCENT REMAINING
VOCATIONAL EDUCATION	\$ 100,636.42	\$ 96,350.38	\$ 4,286.04	4.26%
TOTALS	\$ 100,636.42	\$ 96,350.38	\$ 4,286.04	4.26%

FEDERAL PGMS. - LITERACY STIPEND GRANT	BUDGET	EXPENDED	REMAINING	PERCENT REMAINING
EARLY CHILDHOOD EDUCATION	\$ 18,000.00	\$ 18,000.00	\$ -	0.00%
TOTALS	\$ 18,000.00	\$ 18,000.00	\$ -	0.00%

TOTAL FEDERAL PROGRAMS	\$ 9,537,724.83	\$ 4,910,912.32	\$ 4,626,812.51	48.51%
-------------------------------	------------------------	------------------------	------------------------	---------------

Hamblen County Government
Personnel Committee
Monday, June 15, 2026
Large Courtroom-Hamblen County Courthouse

MINUTES

Members Present:

Stan Harville, Thomas Doty, Bobby Haun, Debbie A’Hearn, Jamie Carden, Edna Greene, Tim Horner, Peggy Howell, Rodney Long, Wayne NeSmith, Mike Reed, Mike Richardson, Kyle Walker

Members Absent:

Joe Huntsman, Sr.

Call to Order

Chairman Stan Harville called the meeting to order at 5:39 p.m.

Visitors Wishing to Address the Committee

- a. None

Old Business

- a. None

New Business

- a. Approval of Education Pay Submissions
Motion (Tim Horner/Jamie Carden, all in favor) to approve the Education Pay Submissions for June 2026.
- b. Approval of Longevity Pay Submission
Motion (Kyle Walker/Rodney Long, all in favor) to approve the Longevity Pay Submission for June 2026.

Items of Interest (No Action Necessary)

- a. None

Adjournment

There being no further business Chairman Harville adjourned the meeting at 5:40 p.m.



Hamblen County Government
PERSONNEL COMMITTEE

Monday, June 15, 2026
Immediately Following Adjournment of Finance Committee
Large Courtroom – Hamblen County Courthouse

**PERSONNEL
COMMITTEE**

Stan Harville
Chairman

Thomas Doty
Vice-Chairman

Bobby Haun
Ex-Officio

Debbie A’Hearn
Member

Jamie Carden
Member

Edna Greene
Member

Tim Horner
Member

Peggy Howell
Member

Joe Huntsman, Sr.
Member

Rodney Long
Member

Wayne NeSmith
Member

Mike Reed
Member

Mike Richardson
Member

Kyle Walker
Member

AGENDA

1. **Call to Order** – *Chairman Stan Harville*
2. **Visitors Wishing to Address the Committee about Agenda Items Only** –
Chairman Stan Harville (Visitors will allotted 3 minutes to speak)
3. **Old Business** – *Chairman Stan Harville*
 - a. None
4. **New Business** – *Chairman Stan Harville*
 - a. Approval of Education Pay Submissions
 - b. Approval of Longevity Pay Submission
5. **Items of Interest (No Action Necessary)** – *Chairman Stan Harville*
 - a. None
6. **Adjournment** – *Chairman Stan Harville*

HAMBLLEN COUNTY, TENNESSEE
OFFICE OF COUNTY MAYOR
EDUCATION & LONGEVITY PAY APPLICANT PRESENTED TO
THE PERSONNEL COMMITTEE ON
June 15, 2026

EDUCATION

Last Name	First Name	Education	Amount
Lawson	Jules	Bachelor's	\$850
Ross	Millie	Bachelor's	\$850

LONGEVITY

Last Name	First Name	Hire Date	Amount	Years of Service
Farris	Carrie	5/8/2023	\$225.00	3

Hamblen County Government
Public Services Committee
Monday, June 15, 2026
Large Courtroom-Hamblen County Courthouse
MINUTES

Members Present

Mike Richardson, Stan Harville, Bobby Haun, Debbie A’Hearn, Peggy Howell, Rodney Long, Mike Reed, Kyle Walker

Members Absent

Joe Huntsman, Sr.

Call to Order

Chairman Mike Richardson called the meeting to order at 5:40 p.m.

Visitors Wishing to Address the Committee

Gwen Holden

Old Business

- a. None

New Business

- a. Resolution 26-__-A Resolution to Amend the Subdivision Regulations of Hamblen County, Tennessee by Amending the Cul-De-Sac Size for New Subdivisions From 40 Feet to 50 Feet
Motion (Peggy Howell/Debbie A’Hearn, all in favor) to approve Resolution 26-__-A Resolution to Amend the Subdivision Regulations of Hamblen County, Tennessee by Amending the Cul-De-Sac Size for New Subdivisions From 40 Feet to 50 Feet
- b. Resolution 26-__-A Resolution to Update the Hamblen County, Tennessee Stormwater Program in Order to be in Compliance With TDEC
Motion (Stan Harville/Kyle Walker, all in favor) to approve Resolution 26-__- A Resolution to Update the Hamblen County, Tennessee Stormwater Program in Order to be in Compliance With TDEC
- c. 2026-2027 Road Paving Plan
Motion (Rodney Long/Stan Harville, all in favor) to approve the 2026-2027 Road Paving Plan

Items of Interest (No Action Necessary)

- a. None

Adjournment

There being no further business Chairman Richardson adjourned the meeting at 5:46 p.m.

Hamblen County Government
PUBLIC SERVICES COMMITTEE

Monday, June 15, 2026

Immediately Following the Adjournment of the Personnel Committee
Large Courtroom – Hamblen County Courthouse



**PUBLIC SERVICES
COMMITTEE**

Mike Richardson
Chairman

Stan Harville
Vice-Chairman

Bobby Haun
Ex-Officio

Debbie A'Hearn
Member

Peggy Howell
Member

Joe Huntsman, Sr.
Member

Rodney Long
Member

Mike Reed
Member

Kyle Walker
Member

AGENDA

1. **Call to Order** – *Chairman Mike Richardson*
2. **Visitors Wishing to Address the Committee about Agenda Items Only** –
Chairman Mike Richardson (Visitors will be allotted 3 minutes to speak)
3. **Old Business** – *Chairman Mike Richardson*
 - a. None
4. **New Business** – *Chairman Mike Richardson*
 - a. Resolution 26-____-A Resolution to Amend the Subdivision Regulations of Hamblen County, Tennessee by Amending the Cul-De-Sac Size for New Subdivisions From 40 Feet to 50 Feet-*Tommy McKinney Planning and Zoning Manager*
 - b. Resolution 26-____-A Resolution to Update the Hamblen County, Tennessee Stormwater Program in Order to be in Compliance With TDEC-*Tommy McKinney Planning and Zoning Manager*
 - c. 2026-2027 Road Paving Plan-*Mike Richardson Hamblen County Highway Department*
5. **Items of Interest (No Action Necessary)** – *Chairman Mike Richardson*
 - a. None
6. **Adjournment** – *Chairman Mike Richardson*

RESOLUTION # 26-13

**A RESOLUTION TO AMEND THE SUBDIVISIONS REGULATIONS OF HAMBLLEN COUNTY,
TENNESSEE BY AMENDING THE CUL-DE-SAC SIZE FOR NEW SUBDIVISIONS FROM 40 FEET TO
50 FEET**

June 25, 2026

WHEREAS, The Hamblen County Planning Commission heard the request, at their regular scheduled meeting on May 4, 2026, to amend the Hamblen County Subdivision Regulations to reflect change to cul-de-sac size in future construction from 40 feet to 50 feet.

WHEREAS, The Hamblen County Planning Commission does hereby recommend the change to the Subdivision Regulations on Cul-de-sac size:

NOW, THEREFORE, BE IT RESOLVED that the Hamblen County Board of Commissioners does hereby approve the amendment to the Subdivision Regulations on cul-de-sac size from 40 feet to 50 feet.

Motion was made by _____.

Second by _____.

Voting For:

Voting Against:

ATTEST:

County Clerk

AUTHENTICATED:

County Mayor

Date:

ARTICLE III

GENERAL REQUIREMENTS AND MINIMUM STANDARDS OF DESIGN

A. Streets

1. **Conformity to the Major Road Plan:** The location and width of all streets and roads shall conform to the official major road plan adopted by the Hamblen County Planning Commission.
2. **Relation to Adjoining Street System:** The proposed street system shall extend existing streets and projects. They shall be extended at a width no less than the required minimum width as set forth in this article or the width of the existing street or road, whichever is greater.
3. **Access Streets to Subdivision Boundaries:** Sufficient access streets or right-of-way to adjoining properties shall, at the discretion of the Planning Commission, be provided in subdivisions to permit harmonious development to the area.
4. **Street Right-of-Way Widths:** The minimum width of right-of-way, measured from lot line to lot line, shall be as shown on the major road plan, or if not shown on such plan shall be not less than as follows:

- a. **Major Collector Streets:** 50 feet
- b. **Minor Collector Streets:** 50 feet

(Collector streets are those which carry traffic from minor streets to the major system of arterial streets and highways and include the principal entrance streets of a residential development and streets for major circulation within such a development.)

- c. **Minor Residential Streets:** 50 feet

(Minor streets are those which are used primarily for access to the abutting residential properties and designed to discourage their use by through traffic.)

- d. **Cul-de-Sac Streets:** 40 feet

(Cul-de-sacs are permanent dead-end streets or courts designed so that they cannot be extended in the future.)

- e. **Dead-end Streets:** Not allowed

(Dead-end streets are similar to cul-de-sacs except that they provide no turnaround circle at their closed end and are not permitted as streets in any proposed subdivision. Stub streets planned for future continuation are not considered to be dead-end streets.)

- f. **Marginal Access Streets:** 40 feet

(Marginal access streets are minor streets, which are parallel to and adjacent to arterial streets and highways; and which provide access to abutting properties and protection from through traffic.)

- g. Alleys: 25 feet

(Alleys are minor public ways used primarily for service access to the back or side of properties otherwise abutting on a street. In cases where topography or other physical conditions make a street of the required minimum width impracticable, the Planning Commission may modify the above requirements. Through proposed neighborhood or local business areas, the street right-of-way width shall be increased ten (10) feet on each side to provide for movement of vehicle into and out of necessary off-street parking areas without interference to traffic.)

5. Additional Right-of-Way Width on Existing Streets:

(Subdivisions that adjoin existing streets shall dedicate additional right-of-way to meet the above minimum street width requirements.)

- a. The entire right-of-way shall be provided where any part of the subdivision is on both sides of the existing street.
- b. When the subdivision is located on only one side of the existing street, one-half of the required right-of-way, measured from the center-line of the existing roadway, shall be provided.

6. Restriction of Access: Where a subdivision abuts or contains an existing or proposed major street, the Planning Commission may require marginal access streets, reverse frontage with screen planting contained in a non-access reservation along the rear property line, or such other treatment as may be necessary for adequate protection of residential properties to afford separation of through and local traffic.

7. Street Grades:

- a. Arterial Maximum Grade: (The maximum grade on arterial streets shall not exceed six (6) percent.)
- b. Major Collector Maximum Grade: (The maximum grade on major collector streets shall not exceed eight (8) percent.)
- c. Minor Collector and Minor Residential Streets, Maximum Grade: (The maximum grade on minor collector streets, minor residential streets, and cui-de-sacs shall not exceed sixteen (16) percent.)

8. Horizontal Curves: Where a deflection angle of more than ten (10) degrees in the alignment of a street occurs, a curve of reasonably long radius shall be introduced. On streets sixty (60) feet or more in width, the center line radius of curvature shall be not less than three hundred (300) feet; on other streets, not less than one hundred (100) feet.

9. Vertical Curves: All changes in grade shall be connected by vertical curves of minimum length for other streets. Profiles of all streets showing natural and finished grades drawn to a scale of not less than one (1) inch equals one hundred (100) feet horizontal, and one (1) inch equals ten (10) feet vertical, may be required by the Planning Commission.
10. Intersections: Street intersections shall be as nearly at right angles as is possible, and no intersection shall be at an angle of less than sixty (60) degrees. Property line radii at street intersections shall not be less than twenty (20) feet, and where the angle of street intersection is less than seventy-five (75) degrees, the Commission may require a greater curb radius, having a desirable radius without curtailing the sidewalk at a street corner to less than normal width, the property line at such street corner shall be rounded or otherwise set back sufficiently to permit such construction.

At grade intersections shall be located to provide adequate sight distance as follows:

- a. Major streets (arterial streets and highways and major collectors): minimum sight distance of six hundred (600) feet, measured between points five (5) feet above center line of roadway.
- b. Minor collector streets: minimum sight distance of four hundred (400) feet, measured between points five (5) feet above the center line of roadway.
- c. Other minor streets (local streets, marginal access streets, and cui-de-sacs): minimum sight distance of two hundred and fifty (250) feet, measured between points five (5) feet above center line of roadway.

The Planning Commission may, when it deems necessary to do so in the interest of public safety, increase sight distance requirements or reduce sight distance requirements because of topographic characteristics.

11. Tangents: Reverse curves in road right-of-way shall be connected by tangents of not less than one hundred (100) feet in length for major streets, seventy-five (75) feet for minor collector streets, and fifty (50) feet for other minor streets.
12. Street Jogs: Street jogs with center line offsets of less than one hundred twenty-five (125) feet shall not be allowed.
13. Cul-de-Sac Streets: Cui-de-sacs shall not be longer than one thousand (1,000) feet, measured along the center line from the entrance street right of way to the center of the tum-around. The cul-de-sac tum-around shall have a right-of-way radius of fifty (50) feet and a roadway radius of forty (40) feet. It shall also have a transition curve radius of not less than seventy-five (75) feet to connect the tum-around with the end of the street. The length and design of the cul-de-sac may be varied by the planning commission due to topographical conditions.
14. Temporary Dead-End Streets: Where in the opinion of the Planning Commission, it is desirable to provide for street access to adjoining property, proposed streets shall be extended by dedication to the boundary of such property. Such dead-end streets shall be

provided with a temporary turn-around having a roadway diameter of at least eighty (80) feet.

15. Private Streets and Reserve Strips: There shall be no private streets platted in any subdivision. Every lot in the subdivided property shall be served from a publicly dedicated street. There shall be no reserve strips controlling access to streets, except where the control of such strips is definitely placed with the community under conditions approved by the Planning Commission.
16. Street Names: Proposed streets, which obviously in alignment with others already exist and named, shall bear the names of the existing streets. In no case shall the name for proposed streets duplicate existing street names, irrespective of the use of the Suffix Street, avenue, boulevard, driveway, place or court. The Planning Commission can assist the sub divider in avoiding duplication.
17. Alleys: Alleys shall be provided to the rear of all lots used for business purposes, and shall not be provided in residential blocks except where the sub divider produces evidence satisfactory to the Planning Commission of the need for alleys.
18. Surface Drainage: All streets and roads must be so designed as to provide for the discharge of surface water from the right-of-way of all streets and roads by grading and drainage as shall be approved by the Planning Commission. Where it is the opinion of the Planning Commission that water cannot be adequately discharged by surface drainage, the Planning Commission may require the installation of a storm water system.

B. Blocks

1. Length: Blocks shall not be less than four hundred (400) feet nor more than twelve hundred (1200) feet in length, except as the Planning Commission considers necessary to secure efficient use of land or desired features of street pattern.
2. Width: blocks shall be wide enough to allow two (2) rows of lots, except where reverse frontage on major streets and roads is provided or where prevented by topographical conditions or size of the property; in which case, the Planning Commission may approve a single row of lots of minimum depth.

C. Lots

1. Arrangement: Insofar as practical, side lot lines shall be at right angles to straight street lines or radio t curved street lines. Each lot must front for a minimum of fifty (50) feet upon a public street or road, this width to be maintained continually from street upon reaching the building setback line, except in special instances, such as cui- de-sacs; in which case each lot must have frontage of at least forty (40) feet. In the event that a parcel or tract of land has less than one hundred (100) feet, but eighty (80) or more feet frontage on a public street or road and is therefore incapable of being subdivided under these regulations then, and in that event, a subdivision of such parcel of land will be allowed so long as each of the remaining lots, after subdivision, has at least forty (40) feet

RESOLUTION 26-14

A RESOLUTION TO UPDATE THE HAMBLLEN COUNTY, TENNESSEE STORMWATER PROGRAM IN ORDER TO BE IN COMPLIANCE WITH TDEC

SECTION

- 1-101. General provisions.
- 1-102. Definitions.
- 1-103. Construction Stormwater Management
- 1-104. Permanent stormwater management: design and construction inspection.
- 1-105. Permanent Stormwater Control Measure (SCM) maintenance and inspection.
- 1-106. Permanent SCM's: new, existing, and ongoing developments.
- 1-107. Illicit discharges.
- 1-108. Enforcement
- 1-109. Penalties.
- 1-110. Appeals.

1-101 General provisions

- (1) Purpose. It is the purpose of this chapter to:
 - a. Protect, maintain, and enhance the environment of Hamblen County and the public health, safety and the general welfare of the citizens of the County, by controlling discharges of pollutants to the County's stormwater system and to maintain and improve the quality of the receiving waters into which the stormwater outfalls flow, including, without limitation, lakes, rivers, streams, ponds, wetlands, and groundwater of the County;
 - b. Enable Hamblen County to comply with the National Pollution Discharge Elimination System permit (NPDES) and applicable regulations, 40 CFR § 122 as applicable for stormwater discharges;
 - c. Allow the County to exercise the powers granted in Tennessee Code Annotated § 68-221-1105, which provides that, among other powers cities have with respect to stormwater facilities, is the power by resolution to:
 - i. Exercise general regulation over the planning, location, construction, and operation and maintenance of stormwater facilities in the County, whether or not owned and operated by the County;
 - ii. Adopt any rules and regulations deemed necessary to accomplish the purposes of this statute, including the adoption of a system of fees for services and permits;
 - iii. Establish standards to regulate the quantity of stormwater discharged and to regulate stormwater contaminants as may be necessary to protect water quality;

- iv. Review and approve plans and plats for stormwater management in proposed subdivisions or commercial developments;
- v. Issue permits for stormwater discharges, or for the construction, alteration, extension, or repair of stormwater facilities;
- vi. Suspend or revoke permits when it is determined that the permittee has violated any applicable ordinance, resolution, or condition of the permit;
- vii. Regulate and prohibit discharges into stormwater facilities of sanitary, industrial, or commercial sewage or waters that have otherwise been contaminated; and
- viii. Expend funds to remediate or mitigate the detrimental effects of contaminated land or other sources of stormwater contamination, whether public or private.

(2) Administering entity. Hamblen County shall administer the provisions of this chapter.

(3) Stormwater management resolution. The intended purpose of this resolution is to safeguard property and public welfare by regulating stormwater drainage and requiring temporary and permanent provisions for its control. It should be used as a planning and engineering tool for permit compliance and to facilitate the necessary control of stormwater.

1-102. Definitions. For the purpose of this chapter, the following definitions shall apply:

Words used in the singular shall include the plural, and the plural shall include the singular; words used in the present tense shall include the future tense. The word “shall” is mandatory and not discretionary. The word “may” is permissive. Words not defined in this section shall be construed to have the meaning given by common and ordinary use as defined in the latest edition of Webster’s Dictionary.

1. **Administrative or Civil Penalties** - Under the authority provided in Tennessee Code Annotated § 68-221-1106, Hamblen County declares that any person violating the provisions of this chapter may be assessed a civil penalty by the County of not less than fifty dollars (\$50.00) and not more than five thousand dollars (\$5,000.00) per day for each day of violation. Each day of violation shall constitute a separate violation.
2. **Analytical monitoring-Test Procedures for the Analysis of Pollutants** - Test procedures for the analysis of pollutants shall conform to regulations published pursuant to Section 304 (h) of the Clean Water Act (the "Act"), as amended, under which such procedures may be required. Pollutant parameters shall be determined using sufficiently sensitive methods in Title 40 C.F.R. § 136, as amended, and promulgated pursuant to Section 304 (h) of the Act. The chosen methods must be sufficiently sensitive as required in state rule 0400-40-03-.05(8).
3. **Aquatic Resource Alteration Permit (ARAP)** physical alterations to properties of the waters of the state require an ARAP or a §401 Water Quality Certification (§401 certification). ARAP means a permit issued pursuant to T.C.A. § 69-3-108 of the Act, which authorizes the alteration of properties of waters of the state that result from activities other than discharges of wastewater through a pipe, ditch, or other conveyance.

4. **As built plans (record drawings)** mean drawings depicting conditions as they were actually constructed.
5. **Best Management Practices (“BMPs”)** means schedules of activities, prohibitions of practices, maintenance procedures and other management practices to prevent or reduce the discharge of pollutants to waters of the state. BMPs also include treatment requirements, operating procedures; and practices to control plant site runoff, spillage, leaks, sludge or waste disposal, or drainage from raw material storage. BMPs include source control practices (non-structural BMPs), and engineered structures designed to treat runoff.
 - Structural BMPs are facilities that help prevent pollutants in stormwater runoff from leaving the site.
 - Non-structural BMPs are techniques, activities and processes that reduce pollutants at the source.
6. **BMP Manual** provides technical guidance including additional policies, criteria, standards, specifications, constants, and information for the proper implementation of the requirements of the National Pollution Discharge Elimination System permit (NPDES) and applicable regulations, 40 CFR § 122 as applicable for stormwater discharges.
7. **Borrow Pit** is an excavation from which erodible material (typically soil) is removed to be fill for another site. There is no processing or separation of erodible material conducted at the site. Given the nature of activity and pollutants present at such excavation, a borrow pit is considered a construction activity.
8. **Buffer Zone or Water Quality Riparian Buffer** is a permanent strip of natural perennial vegetation, adjacent to a stream, river, wetland, pond, or lake that contains dense vegetation made up of grass, shrubs, and/or trees. The purpose of a water quality riparian buffer is to maintain existing water quality by minimizing risk of any potential sediments, nutrients or other pollutants reaching adjacent surface waters and to further prevent negative water quality impacts by providing canopy over adjacent waters. Stream buffers are measured from the top of bank, not the centerline on the stream.
9. **Channel** means a natural or artificial watercourse with a definite bed and banks that conveys continuously or periodically flowing water.
10. **Clearing** refers to removal of vegetation and disturbance of soil prior to grading or excavation in anticipation of construction activities. Clearing may also refer to wide area land disturbance in anticipation of non-construction activities. Clearing, grading, and excavation do not refer to clearing of vegetation along existing or new roadways, highways, dams, or power lines for sight distance or other maintenance and/or safety concerns, or cold planing, milling, and/or removal of concrete and/or bituminous asphalt roadway pavement surfaces. The clearing of land for agricultural purposes is exempt from federal stormwater NPDES permitting in accordance with Section 401(1)(1) of the 1987 Water Quality Act and state stormwater NPDES permitting in accordance with the Tennessee Water Quality Control Act of 1977 (T.C.A. 69-3-101 et seq.).
11. **Commencement of construction:** the initial disturbance of soils associated with clearing, grading, excavating or other construction activities.

12. **Common plan of development or sale** is broadly defined as any announcement or documentation (including a sign, public notice or hearing, sales pitch, advertisement, drawing, permit application, zoning request, computer design, etc.) or physical demarcation (including boundary signs, lot stakes, surveyor markings, etc.) indicating construction activities may occur on a specific plot. A common plan of development or sale identifies a situation in which multiple areas of disturbance are occurring on contiguous areas. This applies because the activities may take place at different times, on different schedules, by different operators.
13. **Control measure** refers to any Best Management Practice (BMP) or other method used to prevent or reduce the discharge of pollutants to waters of the state.
14. **CWA** means the Clean Water Act of 1977 or the Federal Water Pollution Control Act (33 U.S.C. 1251, et seq.)
15. **Design storm** is a storm event as defined by Precipitation-Frequency Atlas of the United States. Atlas 14. Volume 2. Version 3.0. U.S. Department of Commerce. National Oceanic and Atmospheric Administration (NOAA), National Weather Service, Hydrometeorological Design Studies Center, Silver Springs, Maryland or its digital product equivalent. The estimated design rainfall amounts, for any return period interval (i.e., 1-yr, 2-yr, 5-yr, 25-yr, etc.,) in terms of either depths or intensities for any duration, can be found by accessing the data available at https://hdsc.nws.noaa.gov/hdsc/pfds/pfds_map_cont.html . The design storm events for Hamblen County are:

Storm Event	1-yr, 24-hr	2-yr, 24-hr	5-yr, 24-hr	10-yr, 24-hr	100-yr, 24-hr
Precipitation Depth	2.41"	2.86"	3.45"	3.94"	5.75"

16. **Discharge or discharge of a pollutant** refers to the addition of pollutants to waters from a source.
17. **Ecoregion** is a relatively homogeneous area defined by similarity of climate, landform, soil, potential natural vegetation, hydrology, or other ecologically relevant variables. Ecoregions can be determined for specific stream segments by using Tennessee’s Online Water Quality Assessment Data viewer <http://tdeconline.tn.gov/dwr>.
18. **Exceptional Tennessee Waters** are surface waters designated by the Tennessee Department of Environment and Conservation as having the characteristics set forth at Tennessee Rules, Chapter 0400-40-03-.06(4). Characteristics include waters within parks or refuges; scenic rivers; waters with threatened or endangered species; waters that provide specialized recreational opportunities; waters within areas designated as lands unsuitable for mining; waters with naturally reproducing trout; waters with exceptional biological diversity and other waters with outstanding ecological or recreational value.
19. **Hot spot** means an area where land use or activities generate highly contaminated runoff, with concentrations of pollutants in excess of those typically found in stormwater. Examples might include operations producing concrete or asphalt, auto repair shops, auto supply shops, large commercial parking areas and restaurants.

20. **Improved sinkhole** is a natural surface depression that has been altered in order to direct fluids into the hole opening. Improved sinkhole is a type of injection well regulated under the Underground Injection Control (UIC) program of the Tennessee Department of Environment and Conservation. Underground injection constitutes an intentional disposal of waste waters in natural depressions, open fractures and crevices, such as those commonly associated with weathering of limestone. More information regarding an Underground Injection Control Permit can be found on TDEC's DWR webpage at <https://www.tn.gov/content/tn/environment/permit-permits/water-permits1/underground-injection-control-permit.html>
21. **Level 1** - Fundamentals of Erosion Prevention and Sediment Control training and certification program administered by University of Tennessee Water Resources Research Center (<https://tnepsc.org/index.asp>).
22. **Level 2** - Design Principles for Erosion Prevention and Sediment Control for Construction Sites training and certification program administered by University of Tennessee Water Resources Research Center (<https://tnepsc.org/index.asp>).
23. **Linear Project** is a land disturbing activity as conducted by an underground/overhead utility or highway department, including, but not limited to, any cable line or wire for the transmission of electrical energy; any conveyance pipeline for transportation of gaseous or liquid substance; any cable line or wire for communications; or any other energy resource transmission ROW or utility infrastructure, e.g., roads and highways. Activities include the construction and installation of these utilities within a corridor. Linear project activities also include the construction of access roads, staging areas and borrow/spoil sites associated with the linear project. Land disturbance specific to the development of residential and commercial subdivisions is not considered a linear project.
24. **Monitoring** refers to tracking or measuring activities, progress, results, etc., and can refer to non-analytical monitoring for pollutants by means other than 40 C.F.R. § 136 (and other than state- or federally established protocols in the case of biological monitoring and assessments), such as visually or by qualitative tools that provide comparative values or rough estimates.
25. **Municipality** means any incorporated County or town, county, metropolitan or consolidated government, or special district of this state empowered to provide storm water facilities.
26. **Operator** means any person who owns, leases, operates, controls, or supervises a source. Including, but not limited to, an owner or operator of any "facility or activity" subject to regulation under the NPDES program.
27. **Permanent Stabilization** means that all soil disturbing activities at the site have been completed and one of the three following criteria is met:
- A perennial, preferably native, vegetative cover with a uniform (i.e., evenly distributed, without large bare areas) density of at least 70 percent has been established on all unpaved areas and areas not covered by permanent structures, and all slopes and channels have been permanently stabilized against erosion.

- Equivalent permanent stabilization measures such as the use of riprap; permanent geotextiles; hardened surface materials including concrete, asphalt, gabion baskets have been employed.
 - For construction projects on land used for agricultural or silvicultural purposes, permanent stabilization may be accomplished by returning the disturbed land to its preconstruction agricultural or silvicultural use.
28. **Point source** (or Outfall) means any discernible, confined, and discrete conveyance, including but not limited to, any pipe, ditch, channel, tunnel, conduit, well, discrete fissure, container, rolling stock, concentrated animal feeding operation, landfill leachate collection system, vessel or other floating craft from which pollutants are or may be discharged. This term does not include introduction of pollutants from non-point source agricultural and silvicultural activities, including stormwater runoff from orchards, cultivated crops, pastures, range lands, forest lands or return flows from irrigated agriculture or agricultural stormwater runoff. In short, outfall is a point where runoff leaves the site as a concentrated flow in a discrete conveyance.
29. **Pollutant** means sewage, industrial wastes, or other wastes.
30. **Priority Construction** means those construction activities discharging directly into, or immediately upstream of, waters the state recognized as impaired for siltation or Exceptional Tennessee Waters.
31. A **rainfall event** is defined as any occurrence of rain preceded by 10 hours without precipitation that results in an accumulation of 0.01 inches or more. Instances of rainfall occurring within 10 hours of each other will be considered a single rainfall event.
32. **Registered Engineer and Registered Landscape Architect** An engineer or landscape architect certified and registered by the State Board of Architectural and Engineer Examiners pursuant to Section 62-202, Tennessee Code Annotated, to practice in Tennessee.
33. **Runoff coefficient** means the fraction of total rainfall that will appear at the conveyance as runoff. Runoff coefficient is also defined as the ratio of the amount of water that is not absorbed by the surface to the total amount of water that falls during a rainstorm.
34. **Sediment** means solid material, both inorganic (mineral) and organic, that is in suspension, is being transported; or has been moved from the site of origin by wind, water, gravity or ice as a product of erosion.
35. **Sediment basin** A temporary basin consisting of an embankment constructed across a wet weather conveyance, an excavation that creates a basin or by a combination of both. A sediment basin typically consists of a forebay cell, impoundment, permanent pool, primary spillway, secondary or emergency spillway and surface dewatering device. The size and shape of the basin depends on the location, size of drainage area, incoming runoff volume and peak flow, soil type and particle size, land cover, and receiving stream classification (i.e., waters with unavailable parameters, Exceptional TN Waters, or waters with available parameters).
36. **Sedimentation** means the action or process of forming or depositing sediment.

37. **Significant Contributor** is defined as a source of pollutants where the volume, concentration, or mass of a pollutant in a stormwater discharge can cause or threaten to cause pollution, contamination, or nuisance that adversely impact human health or the environment and cause or contribute to a violation of any applicable water quality standards for receiving water.
38. **Soil or Topsoil** means the unconsolidated mineral and organic material on the immediate surface of the earth that serves as a natural medium for the growth of plants.
39. **Steep Slope or Steep Grade** means a natural or created slope of 35% grade or greater.
40. **Stormwater** means rainfall runoff, snow melt runoff, and surface runoff and drainage.
41. **Stormwater control measure or SCM** means permanent practices and measures designed to reduce the discharge of pollutants from new development projects or redevelopment projects.
42. **Stream** as defined by TCA 69-3-103(38) "stream" means a surface water that is not a wet weather conveyance.
43. **Stormwater associated with industrial activity** is defined in 40 C.F.R. 122.26(b)(14) and incorporated here by reference. Most relevant to the County is 40 C.F.R. 122.26(b)(14)(x), which relates to construction activity including clearing, grubbing, grading, filling and excavation activities, including borrow pits containing erodible material. Disturbance of soil for the purpose of crop production is exempt from NPDES permit requirements, but stormwater discharges from agriculture-related activities that involve construction of structures (e.g., barn construction, road construction, pond construction) are considered associated with industrial (construction) activity. Maintenance to the original line and grade, hydraulic capacity; or to the original purpose of the facility (e.g., re-clearing, minor excavation performed around an existing structure necessary for maintenance or repair and repaving of an existing road) is not considered a construction activity.
44. Construction **Stormwater discharge-related activities** means activities that cause, contribute to or result in point source stormwater pollutant discharges. These activities may include excavation, site development, grading and other surface disturbance activities; and activities to control stormwater including the siting, construction and operation of best management practices (BMPs).
45. **Stormwater Pollution Prevention Plan (SWPPP)** is a written site-specific plan required by the Tennessee Construction General Permit (CGP) that includes a narrative pollution prevention plan and graphical erosion and sediment control plan. In its basic form, the plan contains a site map, a description of construction activities that could introduce pollutants to stormwater runoff, a description of measures or practices to control these pollutants, and erosion and sediment control plans and specifications. The SWPPP should be prepared in accordance with the Tennessee Erosion and Sediment Control Handbook (latest edition).
46. **Take of an endangered species** means to harass, harm, pursue, hunt, shoot, wound, kill, trap, capture or collect, or attempt to engage in any such conduct.

47. **Tennessee Erosion and Sediment Control Handbook** is a guidance issued by the Division of Water Resources for the purpose of developing Stormwater Pollution Prevention Plans and Erosion and Sediment Control Plans required by the Construction General Permit CGP.
48. **Temporary stabilization** is achieved when vegetation or non-erodible surface has been established on the area of disturbance and construction activity has temporarily ceased. Under certain conditions, temporary stabilization is required when construction activities temporarily cease.
49. **Treatment chemicals** are polymers, flocculants or other chemicals used to reduce turbidity in stormwater discharges by chemically bonding to suspended silts and other soil materials and causing them to bind together and settle out. Common examples of anionic treatment chemicals are **polyacrylamide-chitosan (PAM-CS)**.
50. **Turbidity** is the cloudiness or haziness of a fluid caused by individual particles (suspended solids) that are generally invisible to the naked eye, similar to smoke in air.
51. **Urban Area** is the designated area within the County, which is determined by the latest decennial census by the United States Census Bureau. An updated map is kept in the Planning and Codes Department office and can be found on the department website.
52. **Waste site** is an area where material from a construction site is disposed of. When the material is erodible, such as soil, the site must be treated as a construction site.
53. **Waters** (or waters of the state) means any and all water, public or private, on or beneath the surface of the ground, which are contained within, flow through, or border upon Tennessee or any portion thereof, except those bodies of water confined to and retained within the limits of private property in single ownership which do not combine or effect a junction with natural surface or underground waters.
54. **Waters with unavailable parameters** means any segment of surface waters that has been identified by the TDEC as impaired or failing to support one or more classified uses. Unavailable parameters exist where water quality is at, or fails to meet, the levels specified in water quality criteria in Rule 0400-40-03-.03, even if caused by natural conditions. In the case of a criterion that is a single response variable or is derived from measurement of multiple response variables, the unavailable parameters shall be the agents causing water quality to be at or failing to meet the levels specified in criteria. Resources to be used in making this determination include biennial compilations of impaired waters, databases of assessment information, updated GIS coverages (<https://tdeconline.tn.gov/dwr/>), and the results of recent field surveys. GIS coverages of the streams and lakes not meeting water quality standards, plus the biennial list of waters with unavailable parameters, can be found at <https://www.tn.gov/environment/program-areas/wr-water-resources/water-quality/water-quality-reports---publications.html>.
55. **Water quality riparian buffer** means a permanent strip of natural perennial vegetation adjacent to a stream, river, wetland, pond, or lake that contains dense vegetation made up of grass, shrubs, and/or trees. The purpose of a water quality riparian buffer is to maintain existing water quality by minimizing the risk of any potential sediments, nutrients, or other pollutants reaching

adjacent surface waters and to further prevent negative water quality impacts by providing canopy over adjacent waters.

56. A **one-week period** is a synonym of a calendar-week; typically, a period from Sunday through Saturday

57. **Water quality treatment volume (WQTV)** is a portion of the runoff generated from impervious surfaces at a new development or redevelopment project by the 1-year 24-hour design storm. The WQTV is further determined by the type of treatment provided.

58. **Wet weather conveyances** are man-made or natural watercourses, including natural watercourses that have been modified by channelization, that meet the following:

- The conveyance carries flow only in direct response to precipitation runoff in its immediate locality.
- The conveyance’s channels are at all times above the groundwater table.
- The flow carried by the conveyance is not suitable for drinking water supplies.
- Hydrological and biological analyses indicate that, due to naturally occurring ephemeral or low flow under normal weather conditions, there is not sufficient water to support fish or multiple populations of obligate lotic aquatic organisms whose life cycle includes an aquatic phase of at least two months. (Tennessee Rules, Chapter 0400-40-3-.04(3)).

1-103. Construction Stormwater Management

1. MS4 Stormwater Construction BMP Manual.

a. Adoption. Hamblen County adopts as its MS4 stormwater construction BMP manual(s) the following publication(s), which is incorporated by reference in this resolution as if fully set out herein:

- i. TDEC Erosion and Sediment Control Handbook (2026 or most current edition)
- ii. TN Permanent Stormwater Management and Design Guidance Manual (2014 or most current edition)
- iii. **City of Morristown Stormwater Design Guidance Manual (2024 or most current edition)**

b. Hamblen County has adopted, for use in designing Stormwater Control Measures, construction design storm events. The construction design storm events adopted by the County are as follows:

Storm Event	1-yr, 24-hr	2-yr, 24-hr	5-yr, 24-hr	10-yr, 24-hr	100-yr, 24-hr
Precipitation Depth	2.41"	2.86"	3.45"	3.94"	5.75"

- c. Requirements for design storm for all waters as well as special conditions for unavailable parameters waters or exceptional Tennessee waters must be consistent with those of the current Tennessee Construction General Permit (TNR100000).
2. The municipality has adopted, for use in designing EPSC measures, the design storm requirements from the current Tennessee Construction General Permit for all waters as well as special conditions for unavailable parameters or Exceptional Tennessee Waters.
3. Waste Control Construction site operators are required to minimize the exposure of building materials, building products, construction wastes, trash, landscape materials, fertilizers, pesticides, herbicides, detergents, sanitary waste and other materials present on the site to precipitation and to stormwater.
4. Priority Construction
 - a. Priority in construction shall be, at a minimum, those construction activities discharging directly into, or immediately upstream of, waters the state recognized as unavailable condition for siltation or Exceptional Tennessee Waters.
 - b. Requirements for all priority construction activities must include preconstruction meetings with construction site operators for priority construction activities.
5. Land development permit

This section shall be applicable to all land development, including, but not limited to, site plan applications, subdivision applications, land disturbance applications and grading applications. These standards apply to qualifying new development or redevelopment site(s), when required. Every person/entity will be required to obtain a land disturbance permit from the County in the following cases:

- a. One (1) acre or more;
 - i. New development that involves land development activities of one (1) acre or more;
 - ii. Redevelopment that involves other land development activity of one (1) acre or more;
- b. Projects of less than one acre of total land disturbance may also be required to obtain authorization under this resolution if:
 - i. Hamblen County has determined that the stormwater discharge from a site is causing, contributing to, or is likely to contribute to a violation of a state water quality standard; or is likely to be a significant contributor of pollutants to water of the state,
 - ii. changes in state or federal rules require sites of less than one acre that are not part of a larger common plan of development or sale to obtain a stormwater permit;

- iii. any new development or redevelopment, regardless of size, that is defined by the County to be a hot spot land use; or
- iv. the minimum applicability criteria set forth in item (a) above if such activities are part of a larger common plan of development, (see “common plan of development” definition).
- v. The creation and use of borrow pits, that are not permitted under the Tennessee Multi Sector Permit (TMSP), where material is excavated and relocated offsite, and fill sites where materials or earth is deposited by mechanized methods resulting in an increased elevation or grade.
- vi. As determined by the County for single or duplex residential lots of any size, lots that have karst features, adjoining lakes or streams, slopes exceeding fifteen percent (15%), floodplains or streams to cross are required to submit an erosion control and stormwater management plan. Depending on site specific conditions the requirement that the plan be developed by a qualified licensed professional engineer or landscape architect may be waived by the Stormwater Administrator
- vii. Minimal plan requirements shall include pre- and post-stormwater runoff directions, construction access, erosion/sediment control measures, swales, BMPs, and vegetative soil stabilization.
- viii. If unpermitted construction activity is on-going, the County will issue and immediate stop-work order. If, in addition to the County’s permit, a TDEC permit was required but was not obtained, the violator will also be reported to TDEC.

6. Land disturbance Permit

Persons seeking the issuance of any Hamblen County Land Disturbance Permit must provide proof of coverage under the Tennessee Construction General Permit (CGP) (if applicable) when requested; and a copy of the Stormwater Pollution Prevention Plan (SWPPP) to the County when requested.

- a. Copies of additional applicable local, state or federal permits (i.e.: ARAP, UIC, approved hydrologic determination, etc.) must also be provided to the County.
 - b. The County has the authority to withhold local permits prior to receiving copies of the aforementioned permits.
 - c. In circumstances where no such permits have been required, the County may still require a SWPPP as part of the land disturbance permit application.
 - d. **The County Stormwater Coordinator may request bonding to assure stormwater infrastructure is installed in accordance with the approved site plans.**
7. Building Permit. No building permit shall be issued until the applicant has first obtained a Land Disturbance Permit where required by this resolution.
8. Construction site operators are required to implement appropriate erosion prevention and sediment control measures and best management practices. EPSC requirements shall meet the

Tennessee's CGP design storm(s), be consistent with the TDEC EPSC Handbook best management practices and with the requirements of this resolution.

9. Where site assessments are required by the CGP, the operator shall provide a copy of the assessment to the County.
10. Twice-Weekly inspections of the site and the BMP's/SCM's must be performed by an individual who has either received certification under the Level I Fundamentals of Erosion Prevention and Sediment Control course or has other credentials identified as equivalent within this resolution.
11. Landscaping and stabilization requirements.
 - a. Any area of land from which the natural vegetative cover has been either partially or wholly cleared by development activities shall be stabilized. Stabilization measures shall be initiated as soon as possible in portions of the site where construction activities have temporarily or permanently ceased. Temporary or permanent soil stabilization at the construction site (or a phase of the project) must be completed not later than 14 days after the construction activity in that portion of the site has temporarily or permanently ceased. In the following situations, temporary stabilization measures are not required:
 - i. where the initiation of stabilization measures is precluded by snow cover or frozen ground conditions, stabilization measures shall be initiated as soon as practicable; or
 - ii. where construction activity on a portion of the site is temporarily ceased, and earth disturbing activities will be resumed within 14 days.
 - b. For steep slopes of 35% or more, stabilization measures shall be initiated within 7 days Construction buffer zones. Construction buffer zones shall be those water quality buffers and buffer zones as defined in 1-102 above and shall meet the requirements in this resolution and, where appropriate in the TNCGP. The criteria for the width of the construction buffer zone can be established on an average width basis at a project, as long as the minimum width of the buffer zone is more than the required minimum width at any measured location. If the new development or redevelopment site encompasses both sides of a stream, buffer averaging can be applied to both sides, but must be applied independently. Water quality riparian buffer widths are measured from the top of bank also referred to as the "ordinary high-water mark." Construction buffers are not primary sediment control measures and shall not be relied on as such. Stormwater discharges must enter the water quality riparian buffer zone as sheet flow, not as concentrated flow, where site conditions allow. The designer/operator must comply with the vegetation requirements and the permissible land uses set forth for buffers in the TN CGP. Where it is not practicable to maintain a construction water quality riparian buffer, BMPs providing equivalent protection to a receiving stream as a natural water quality riparian buffer must be used.
 - c. In arid, semiarid, and drought-stricken areas where initiating vegetative stabilization measures immediately is infeasible, alternative stabilization measures such as properly anchored mulch, soil binders or matting must be employed.

- d. Cut or fill slopes designed at 2:1 (horizontal:vertical) or greater inclination must include written recommendations from a geotechnical engineer; proposed developments with these slopes must adhere to the recommendations made by a professional engineer licensed in the state of Tennessee.
- 12. Notice of Termination (NOT) the operator shall provide the County with a copy of the NOT when it is issued by TDEC.
- 13. As built plans (record drawings). All applicants are required to submit actual as built plans certified by the design engineer for any structures located on-site after final construction is completed. The plan must show the final design specifications for all stormwater management facilities and must be sealed by a registered professional engineer licensed to practice in Tennessee. A certification by the design engineer certifying that SCM's will function within original design parameters as constructed shall be included. A final inspection by the County is required before any performance security or performance bond will be released. The County shall have the discretion to adopt provisions for a partial pro-rata release of the performance security or performance bond on the completion of various stages of development. In addition, occupation permits shall not be granted until corrections to all BMP's/SCM's have been made and accepted by the County. No bonds or securities shall be released by the County until the department has accepted the as-built plans. The warranty period for any infrastructure to be accepted by the County for maintenance shall not commence until the County has accepted the as built plans.
- 14. Equipment manufacturer startups. No bonds or securities shall be released until any equipment to be maintained by the County passes any specified manufacturer startup procedure. The warranty period shall not commence prior to the equipment passing any specified manufacturer startup procedure.

1-104. Permanent stormwater management within Urban Area: design and construction inspection.

- (1) Hamblen County requires permanent stormwater management within the Urban Area as determined by the latest decennial census by the United States Census Bureau; permanent stormwater management is solely limited to those portions of the County.
- (2) In order to comply with Hamblen County's permanent stormwater standards for new development and redevelopment projects, design and install SCMs as established by Tennessee Rule 0400-40-10-.04 and comply with other requirements of Tennessee Rule 0400-40-10-.04.

Water Quality Treatment Volume and the Corresponding SCM Treatment Type for the 1-year, 24-hour Design Storm		
SCM Treatment Type	WQTV	Notes
infiltration, evaporation, transpiration, and/or reuse	runoff generated from the first 1 inch of the design storm	Examples include, but are not limited to, bioretention, stormwater wetlands, and infiltration systems.
biologically active filtration, with an underdrain	runoff generated from the first 1.25 inches of the design storm	To achieve biologically active filtration, SCMs must provide minimum of 12 inches of internal water storage.
sand or gravel filtration, settling ponds, extended detention ponds, and wet ponds	runoff generated from the first 2.5 inches of the design storm or the first 75% of the design storm, whichever is less	Examples include, but are not limited to, sand filters, permeable pavers, and underground gravel detention systems. Ponds must provide forebays comprising a minimum of 10% of the total design volume. Existing regional detention ponds are not subject to the forebay requirement.
hydrodynamic separation, baffle box settling, other flow-through manufactured treatment devices (MTDs), and treatment trains using MTDs	maximum runoff generated from the entire design storm	Flow-through MTDs must provide an overall treatment efficiency of at least 80% TSS reduction. Refer to subparagraph (2)(d) of this rule.

Note that for design purposes, total suspended solids (TSS) may be used as the indicator for the reduction of pollutants.

- (3) SCMs must be designed to provide full treatment capacity within 72 hours following the end of the preceding rain event for the life of the new development or redevelopment project. The designer may select from the most appropriate alternatives listed in the County’s BMP Manual.
- (4) Designs shall be based on the 24-hour design storm adopted by the County:

The County has adopted, for use in designing water quality SCMs, the design storm requirements as established in Tennessee Rule 0400-40-10-.04. The Post Construction/Permanent water quality design storm is a 1-year, 24 storm event for water quality SCMs. See definition of Design Storm Event for the municipality’s rainfall amounts for each return period interval.

1 year:	<u>2.41"</u>
2 year:	<u>2.86"</u>
5 year:	<u>3.45"</u>
10 year:	<u>3.94"</u>
25 year:	<u>4.61"</u>
50 year:	<u>5.17"</u>
100 year:	<u>5.75"</u>

- (5) Water Quality Riparian Buffers. Post Construction/Permanent water quality riparian buffers shall be those buffers defined in 1-102 above and shall meet the requirements described in this resolution. The criteria for the width of the post construction/permanent buffer zone can be established on an average width basis at a project, as long as the minimum width of the buffer zone is more than the required minimum width at any measured location. If the new development or redevelopment site encompasses both sides of a stream, buffer averaging can be applied to both sides but must be applied independently. Water quality riparian buffer widths are measured from the top of bank also referred to as the “ordinary high-water mark.” Stormwater discharges should enter the post construction/permanent water quality riparian buffer as sheet flow, not as concentrated flow, where site conditions allow.

Post Construction/Permanent buffers for waters with available parameters for siltation or habitat alteration or unassessed waters:

- a. Average buffer width: 30 feet.
- b. Minimum buffer width: 15 feet

Post Construction/Permanent buffers for Exceptional Tennessee Waters or waters with unavailable parameters for siltation or habitat alteration:

- a. Average buffer width: 60 feet.
- b. Minimum buffer width: 30 feet

The designer/operator must comply with the vegetation requirements and the permissible land uses set forth for buffers in the MS4 permit.

1-105. Permanent SCM maintenance and inspection (Urban Area only).

- (1) As built plans. All applicants are required to submit actual as built plans for any structures located on-site within 90 days after final construction is completed. The plan must show the final design specifications for all stormwater management facilities and must be sealed by either a registered professional engineer or landscape architect licensed to practice in Tennessee. A sealed certification by the design engineer that all SCM's will function within design parameters as constructed shall accompany the as built plans. A final inspection by the Hamblen County staff is required before any performance security or performance bond will be released. The County shall have the discretion to adopt provisions for a partial pro-rata release of the performance security or performance bond on the completion of various stages of development. In addition, occupation permits shall not be granted until corrections to all stormwater management facilities have been made and accepted by the County.
- (2) In addition to the certified as built drawings, the County shall be provided with a permanent stormwater management plan for the site and all stormwater management facilities (e.g., SCM's). Occupation permits shall not be granted until the permanent stormwater management plan has been approved and accepted by the County.
- (3) Inspection of stormwater management facilities. Periodic inspections of facilities shall be performed, documented, and reported in accordance with this chapter, as detailed in §1-106.
- (4) Records of installation and maintenance activities. Parties responsible for the operation and maintenance of a stormwater management facility shall make records of the installation of the stormwater facility, and of all maintenance and repairs to the facility, and shall retain the records for at least five (5) years. These records shall be made available to the County during inspection of the facility and at other reasonable times upon request.
- (5) Failure to meet or maintain design or maintenance standards. If a responsible party fails or refuses to meet the design or maintenance standards required for stormwater

facilities under this chapter, the County, after notice as specified in the Enforcement Response Plan, may correct a violation of the design standards or maintenance needs by performing all necessary work to place the facility in proper working condition. In the event that the stormwater management facility becomes a danger to public safety or public health, the County shall notify in writing the party responsible for maintenance of the stormwater management facility. Upon receipt of that notice, the responsible person shall have thirty (30) days to effect maintenance and repair of the facility in an approved manner. In the event that corrective action is not undertaken within that time, the County may take necessary corrective action. The cost of any action by the County under this section shall be charged to the responsible party.

- (6) In the event that the stormwater management facility becomes a danger to public health/public safety-the County may take such immediate corrective action as deemed necessary.

1-106. Permanent SCM's: new, existing, and ongoing developments (Urban Area only).

(1) On-site stormwater management facilities inspection and maintenance agreement

- a. Where the stormwater facility is located on property that is subject to a development agreement, and the development agreement provides for a permanent stormwater maintenance agreement that runs with the land, the owners of property must execute an inspection and maintenance agreement that shall operate as a deed restriction binding on the current property owners and all subsequent property owners and their lessees and assigns, including but not limited to, homeowner associations or other groups or entities.
- b. The maintenance agreement shall:
 - i. Assign responsibility for the maintenance and repair of the stormwater facility to the owners of the property upon which the facility is located and be recorded as such on the plat for the property by appropriate notation.
 - ii. Provide for a periodic inspection by the property owners in accordance with the requirements of subsection (5) below for the purpose of documenting maintenance and repair needs and to ensure compliance with the requirements of this resolution. The property owners will arrange for this inspection to be conducted by individual(s) approved by the County who will submit a signed written report of the inspection to the County. It shall also grant permission to the County to enter the property at reasonable times and to inspect the stormwater facility to ensure that it is being properly maintained.
- c. Provide that the minimum maintenance and repair needs include but are not limited to: the removal of silt, litter and other debris, the cutting of grass, cutting and vegetation removal, and the replacement of landscape vegetation, in detention and retention basins, and inlets and drainage pipes and any other stormwater facilities. It shall also provide that the property owners shall be responsible for additional maintenance and repair needed to meet the intended design specification of the stormwater facility.

- d. Provide that maintenance needs must be addressed in a timely manner, on a schedule to be determined by the Hamblen County staff.
- e. Provide that if the property is not maintained or repaired within the prescribed schedule, Hamblen County shall perform the maintenance and repair at its expense and bill the same to the property owner. The maintenance agreement shall also provide that the County's cost of performing the maintenance shall be a lien against the property.

(2) Existing problem locations – no maintenance agreement

- a. The County shall in writing notify the owners of existing locations and developments of specific drainage, erosion or sediment problems affecting or caused by such locations and developments, and the specific actions required to correct those problems. The notice shall also specify a reasonable time for compliance. Discharges from existing SCM's that have not been maintained and/or inspected in accordance with this resolution shall be regarded as non-compliant discharges.
- b. Inspection of existing facilities. The County may, to the extent authorized by state and federal law, enter and inspect private property for the purpose of determining if there are illicit non-stormwater discharges, and to establish inspection programs to verify that all stormwater management facilities are functioning within design limits. These inspection programs may be established on any reasonable basis, including but not limited to: routine inspections; random inspections; inspections based upon complaints or other notice of possible violations; inspection of drainage basins or areas identified as higher than typical sources of sediment or other contaminants or pollutants; inspections of businesses or industries of a type associated with higher than usual discharges of contaminants or pollutants or with discharges of a type which are more likely than the typical discharge to cause violations of the County's NPDES MS4 stormwater permit; and joint inspections with other agencies inspecting under environmental or safety laws. Inspections may include but are not limited to: reviewing maintenance and repair records; sampling discharges, surface water, groundwater, and material or water in drainage control facilities; and evaluating the condition of drainage control facilities and other SCM's.

(3) Owner/Operator Inspections. The owners and/or operators of the SCMs shall:

- a. Perform routine inspections to ensure that all SCM's are properly functioning. These inspections shall be conducted on an annual basis, at a minimum. These inspections shall be conducted by a person familiar with control measures implemented at a site. Owners or operators shall maintain documentation of these inspections. The County may require submittal of this documentation.
- b. Perform comprehensive inspection of all stormwater management facilities and practices. These inspections shall be conducted once every five years, at a minimum.

Such inspections must be conducted by individual(s) approved by the County. Complete inspection reports for these five-year inspections shall include:

- i. Facility type,
 - ii. Inspection date,
 - iii. Latitude and longitude and nearest street address,
 - iv. BMP owner information (e.g. name, address, phone number, fax, and email),
 - v. A description of BMP condition including: vegetation and soils; inlet and outlet channels and structures; embankments, slopes, and safety benches; spillways, weirs, and other control structures; and any sediment and debris accumulation,
 - vi. Photographic documentation of BMP's, and
 - vii. Specific maintenance items or violations that need to be corrected by the BMP owner along with deadlines and reinspection dates.
- c. Owners or operators shall maintain documentation of these inspections. The County may require submittal of this documentation.

(4) Requirements for all existing locations and ongoing developments. The following requirements shall apply to all locations and developments at which land disturbing activities have occurred previous to the enactment of this resolution:

- a. Denuded areas must be vegetated or covered under the standards and guidelines specified in the BMP Manual and on a schedule acceptable to the County.
- b. Cuts and slopes must be properly covered with appropriate vegetation and/or retaining walls constructed.
- c. Drainage ways shall be appropriately stabilized.
- d. Trash, junk, rubbish, etc. shall be cleared from drainage ways.
- e. Stormwater runoff shall, at the discretion of the County, be treated to the maximum extent practicable to prevent its pollution. Such control measures may include, but are not limited to, the following:
 - i. Ponds
 1. Detention pond
 2. Extended detention pond
 3. Wet pond
 4. Alternative storage measures

- ii. Constructed wetlands
- iii. Infiltration systems
 - 1. Infiltration/percolation trench
 - 2. Infiltration basin
 - 3. Drainage/recharge well
 - 4. Porous pavement
- iv. Filtering systems
 - 1. Media Filter
 - 2. Sand filter
 - 3. Filter/absorption bed
 - 4. Filter and buffer strips
- v. Open channel
 - 1. Swale

(5) Corrections of problems subject to appeal. Corrective measures imposed by the County under this section are subject to appeal under section 1-110 of this chapter.

1-107. Illicit discharges.

This section shall apply to all water generated on developed or undeveloped land entering the County's separate storm sewer system.

(1) Prohibition of illicit discharges. No person shall introduce or cause to be introduced into the municipal separate storm sewer system any discharge that is not composed entirely of stormwater. No person shall allow discharges that flow from a stormwater facility that is not inspected in accordance with section 1-106. Non-stormwater discharges shall include, but shall not be limited to, sanitary wastewater, car wash wastewater, radiator flushing disposal, spills from roadway accidents, carpet cleaning wastewater, effluent from septic tanks, improper oil disposal, laundry wastewater/gray water, improper disposal of auto and household toxics. The commencement, conduct or continuance of any non-stormwater discharge to the municipal separate storm sewer system is prohibited except as described as follows:

- a. Water line flushing
- b. Landscape irrigation
- c. Diverted stream flows
- d. Rising ground waters

- e. Uncontaminated ground water infiltration (Infiltration is defined as water other than wastewater that enters a sewer system, including sewer service connections and foundation drains, from the ground through such means as defective pipes, pipe joints, connections, or manholes. Infiltration does not include, and is distinguished from, inflow.)
- f. Uncontaminated pumped ground water
- g. Discharges from potable water sources
- h. Air conditioning condensation
- i. Irrigation water
- j. Springs
- k. Water from crawl space pumps
- l. Footing (foundation) drains
- m. Lawn watering
- n. Individual residential car washing
- o. Flows from riparian habitats and wetlands
- p. Dechlorinated swimming pool discharges
- q. Street wash water with no soaps or solvents
- r. Discharges or flows from firefighting activities

Unless the County determines they are significant contributors of pollutants to the MS4.

(2) Prohibition of illicit connections. The construction, use, maintenance or continued existence of illicit connections to the municipal separate storm sewer system is prohibited. This prohibition expressly includes, without limitation, illicit connections made in the past, regardless of whether the connection was permissible under law or practices applicable or prevailing at the time of connection. This prohibition expressly includes SCM's connected to the system not properly inspected and maintained in accordance with this resolution.

- a. Any person responsible for a property or premises, which is, or may be, the source of an illicit discharge, may be required to implement, at the person's expense, the BMP's necessary to prevent the further discharge of pollutants to the municipal separate storm sewer system. Compliance with all terms and conditions of a valid NPDES permit authorizing the discharge of stormwater associated with industrial activity, to the extent practicable, shall be deemed in compliance with the provisions of this section. Discharges from existing SCM's that have not been maintained and/or inspected in accordance with this resolution shall be prohibited.

- (3) Notification of spills. Notwithstanding other requirements of law, as soon as any person responsible for a facility or operation, or responsible for emergency response for a facility or operation has information of any known or suspected release of materials which are resulting in, or may result in, illicit discharges or pollutants discharging into, the municipal separate storm sewer system, the person shall take all necessary steps to ensure the discovery, containment, and cleanup of such release. In the event of such a release of hazardous materials the person shall immediately notify emergency response agencies of the occurrence via emergency dispatch services. In the event of a release of non-hazardous materials, the person shall notify the County in person or by telephone, fax, or email, no later than the next business day. Notifications in person or by telephone shall be confirmed by written notice addressed and mailed to the County within three (3) business days of the telephone notice. If the discharge of prohibited materials emanates from a commercial or industrial establishment, the owner or operator of such establishment shall also retain an on-site written record of the discharge and the actions taken to prevent its recurrence. Such records shall be retained for at least three (3) years.
- (4) No illegal dumping allowed. No person shall dump or otherwise deposit outside an authorized landfill, convenience center or other authorized garbage or trash collection point, any trash or garbage of any kind or description on any private or public property, occupied or unoccupied, inside the Hamblen County. Such illegal activity exposes runoff to contamination, generating an illicit discharge. Therefore, any individual or corporation guilty of illegal dumping may have committed a violation of this resolution.

1-108. Enforcement.

- (1) Enforcement authority. Hamblen County shall have the authority to issue notices of violation and citations, and to impose civil penalties to anyone that violates this chapter, who violates the provisions of any permit issued pursuant to this chapter, or who fails or refuses to comply with any lawful communication or notice to abate or take corrective action by the County, The County's enforcement authority includes (as set forth in the County's Enforcement Response Plan (ERP)):
 - (a) Verbal Warnings – At a minimum, verbal warnings must specify the nature of the violation and required corrective actions.
 - (b) Written Notices – Written notices must stipulate the nature of the violation and the required corrective action, with deadlines for taking such action.
 - (c) Stop Work Orders – Stop work orders that require construction activities to be halted, except for those activities directed at cleaning up, abating discharge, and installing appropriate control measures.
 - (d) Citations with Administrative Penalties – The County has the authority to assess monetary penalties, which may include civil and administrative penalties.

- (e) **Withholding of Plan Approvals or Other Authorizations** – Where a facility is in noncompliance, the County’s own approval process affecting the facility’s ability to discharge to the MS4 can be used to abate the violation.

- (f) **Additional Measures** – The County may also use other escalated measures provided under local legal authorities. The County may perform work necessary to improve erosion control measures and collect the funds from the responsible party in an appropriate manner, such as collecting against the project’s bond or directly billing the responsible party to pay for work and materials.

(2) Notification of violation:

- (a) **Verbal warning.** Verbal warning may be given at the discretion of the inspector when it appears the condition can be corrected by the violator within a reasonable time, which time shall be approved by the inspector.

- (b) **Written notice.** Whenever Hamblen County staff finds that any permittee or any other person discharging stormwater has violated or is violating this resolution or a permit or order issued hereunder, the County may serve upon such person written notice of the violation. Within ten (10) business days of this notice, an explanation of the violation and a plan for the satisfactory correction and prevention thereof, to include specific required actions, shall be submitted to the County. Submission of this plan in no way relieves the discharger of liability for any violations occurring before or after receipt of the notice of violation.

- (c) **Consent orders.** The County is empowered to enter into consent orders, assurances of voluntary compliance, or other similar documents establishing an agreement with the person responsible for the noncompliance. Such orders will include specific action to be taken by the person to correct the noncompliance within a time period also specified by the order. Consent orders shall have the same force and effect as administrative orders issued pursuant to paragraphs (d) and (e) below.

- (d) **Show cause hearing.** Hamblen County may order any person who violates this chapter or permit, or order issued hereunder, to show cause why a proposed enforcement action should not be taken. Notice shall be served on the person specifying the time and place for the meeting, the proposed enforcement action and the reasons for such action, and a request that the violator show cause why this proposed enforcement action should not be taken. The notice of the meeting shall be served personally or by registered or certified mail (return receipt requested) at least ten (10) days prior to the hearing.

- (e) Compliance order. When Hamblen County finds that any person has violated or continues to violate this chapter or a permit or order issued thereunder, he may issue an order to the violator directing that, following a specific time period, adequate structures or devices be installed and/or procedures implemented and properly operated. Orders may also contain such other requirements as might be reasonably necessary and appropriate to address the noncompliance, including the construction of appropriate structures, installation of devices, self-monitoring, and management practices.

- (f) Cease and desist and stop work orders. When Hamblen County finds that any person has violated or continues to violate this chapter or any permit or order issued hereunder, the County may issue a stop work order or an order to cease and desist all such violations and direct those persons in noncompliance to:
 - (i) Comply forthwith; or
 - (ii) Take such appropriate remedial or preventive action as may be needed to properly address a continuing or threatened violation; including halting operations except for terminating the discharge and installing appropriate control measures.

- (g) Suspension, revocation or modification of permit. Hamblen County may suspend, revoke or modify the permit authorizing the land development project or any other project of the applicant or other responsible person within the County. A suspended, revoked or modified permit may be reinstated after the applicant or other responsible person has taken the remedial measures set forth in the notice of violation or has otherwise cured the violations described therein, provided such permit may be reinstated upon such conditions as the County may deem necessary to enable the applicant or other responsible person to take the necessary remedial measures to cure such violations.

- (h) Conflicting standards. Whenever there is a conflict between any standard contained in this chapter and in the BMP manual(s) adopted by the County under this resolution, the strictest standard shall prevail.

1-109. Penalties. Violations. Any person who shall commit any act declared unlawful under this chapter, who violates any provision of this chapter, who violates the provisions of any permit issued pursuant to this chapter, or who fails or refuses to comply with any lawful communication or notice to abate or take corrective action by the County, shall be guilty of a civil offense.

- (1) Penalties. Under the authority provided in Tennessee Code Annotated § 68-221-1106, the County declares that any person violating the provisions of this chapter may be assessed a civil penalty by the County of not less than fifty dollars (\$50.00) and not more than five thousand dollars (\$5,000.00) per day for each day of violation. Each day of violation shall constitute a separate violation.

- (2) Measuring civil penalties. In assessing a civil penalty, Hamblen County shall consider:
 - (a) The harm done to the public health or the environment;
 - (b) Whether the civil penalty imposed will be a substantial economic deterrent to the illegal activity;
 - (c) The economic benefit gained by the violator;
 - (d) The amount of effort put forth by the violator to remedy this violation;
 - (e) Any unusual or extraordinary enforcement costs incurred by the County; The amount of penalty established by ordinance or resolution for specific categories of violations; and
 - (f) Any equities of the situation which outweigh the benefit of imposing any penalty or damage assessment.

- (3) Recovery of damages and costs. In addition to the civil penalty in subsection (2) above, the County may recover:
 - (a) All damages proximately caused by the violator to the County, which may include any reasonable expenses incurred in investigating violations of, and enforcing compliance with, this chapter, or any other actual damages caused by the violation.
 - (b) A claim against the stormwater bond will be made if infrastructure installation needs to be addressed.
 - (c) The costs of the County's maintenance of stormwater facilities when the user of such facilities fails to maintain them as required by this chapter.

- (4) Referral to TDEC. In accordance with the County's Enforcement Response Plan and the NPDES Permit requirements, the County may also notify TDEC of violations.

- (5) Other remedies. The County may bring legal action to enjoin the continuing violation of this chapter, and the existence of any other remedy, at law or equity, shall be no defense to any such actions.

- (6) Remedies cumulative. The remedies set forth in this section shall be cumulative, not exclusive, and it shall not be a defense to any action, civil or criminal, that one (1) or more of the remedies set forth herein has been sought or granted.

1-110. Appeals. Pursuant to Tennessee Code Annotated § 68-221-1106(d), any person aggrieved by the imposition of a civil penalty or damage assessment as provided by this chapter may appeal said penalty or damage assessment to the Board of Zoning Appeals.

- (1) Appeals to be in writing. The appeal shall be in writing and filed with the municipal recorder or clerk within fifteen (15) days after the civil penalty and/or damage assessment is served in any manner authorized by law.

- (2) Public hearing. Upon receipt of an appeal, Hamblen County's Board of Zoning Appeals shall hold a public hearing within thirty (30) days. Ten (10) days prior notice of the time, date, and location of said hearing shall be published in a daily newspaper of general circulation. Ten (10) days' notice by registered mail shall also be provided to the aggrieved party, such notice to be sent to the address provided by the aggrieved party at the time of appeal. The decision of the governing body of the County shall be final.

- (3) Appealing decisions of the County's governing body. Any alleged violator may appeal a decision of the BZA appeal decision pursuant to the provisions of Tennessee Code Annotated, title 27, chapter 8.

NOW, THEREFORE, BE IT RESOLVED that the Hamblen County Board of Commissioners does hereby approve Resolution 26-14- A Regulation to Update the Hamblen County, Tennessee Stormwater Program in Order to be in Compliance with TDEC.

Motion was made by _____.

Seconded by _____.

Voting for:

Voting Against:

ATTEST:

County Clerk

AUTHENTICATED:

County Mayor

Date:

Completed Road List

24-25 Year	Miles Paved
Lake Park Circle	0.80
Country Road	0.30
Timbercreek	0.22
Rustic Circle	0.06
Pine Barren	0.12
Chucky River Road	0.50
Old Lowland Pike	0.54
Carroll Road	1.00
Old Kentucky Road	0.47
Spencer Hale Road	0.25
Boatmans Mountain	1.00
Elgerlotte Road	0.39
Woodchuck Circle	0.12
Dalton Ford Road	0.38
Fisher Road	0.16
<hr/>	
15 roads at	6.31

25-26 Year	Miles Paved
Amy Drive	0.43
Cherry Blossom Lane	0.2
Plum Court	0.1
Pleasant Ridge Road	0.42
Twin Oaks Road	0.1
Dearing Road	1.37
Helton Gaby Road	0.61
Panther Creek Road	0.8
Cedar Hill Road	0.92
East Brentwood Road	0.61
Alexander Road	0.2
Brights Pike Road	0.45
Stapelton Road	0.3
Shannon Road	0.27
Dover Road	1.25
Stuffel Road	0.87
Jaybird Road	0.42
Shinbone Road	0.5
Slop Creek Road	2.67
Warrensburg Road	0.8
<hr/>	
20 roads at	13.29

Proposed Roads For

26-27 Year	Miles Paved
Jacobs Road	0.91
DeHart Drive	0.30
Vineyard Road	0.34
Spencer Hale Road	0.60
Windchase Drive	0.43
Wells Road	0.58
Beacon Road	0.31
Woodwind Drive	0.17
Terrance Circle	0.12
Briar Court	0.13
Hulls Mill Road	0.42
Wayne Johnson Road	0.37
Chucky River Road	1.78
Dover Road	0.43
Cameron Road	1.15
Murrell Road	0.73
Windcrest Drive	0.44
Crestway Drive	0.29
Crestview Circle	0.06
Stage Coach Road	1.98
Saint Paul Road	0.93
<hr/>	
21 roads at	12.47

56 Roads Paved

32.07 Running Total Miles Roads Paved

**MINUTES FOR HAMBLEN COUNTY
LEGISLATIVE BODY
COMMISSION MEETING**

May 21, 2026

BE IT REMEMBERED that the Legislative Body for Hamblen County, Tennessee met at its regular monthly meeting on May 21, 2026 at 5:00 p.m. in the Hamblen County Courtroom with the Chairman Bobby Haun presiding.

The Legislative Body was opened by Hamblen County Courtroom Security Harley Kelley.

The Invocation was given by Commissioner Debbie A'Hearn.

The Pledge of Allegiance was led by Commissioner Mike Richardson.

roll call, the following members were present:

ROLL CALL RESULTS 12 PRESENT 2 ABSENT

Roll Call Quorum Present

Joe Huntsman	ABSENT	Rodney Long	PRESENT
Debbie Ahearn	PRESENT	Jamie Carden	PRESENT
Thomas Doty	PRESENT	Stan Harville	PRESENT
Wayne NeSmith	PRESENT	Peggy Howell	PRESENT
Mike Reed	PRESENT	Bobby Haun	PRESENT
Mike Richardson	PRESENT	Tim Horner	ABSENT
Kyle Walker	PRESENT	Edna Greene	PRESENT

Hamblen County Legislative Body Regularly Meeting
May 21, 2026

OpenMeeting

APPOINTMENT TO THE MORRISTOWN-HAMBLEN LIBRARY BOARD

Motion by Thomas Doty, seconded by Mike Reed to approve Mike Richardson to begin his first full term as County Board representative on July 1, 2026.

VOTE RESULTS

10 YES 1 NO 1 ABSTAIN 2 ABSENT

3.a. Appointment to the Morristown-Hamblen Library Board

Majority of Full Membership

Passed

Joe Huntsman		ABSENT	Rodney Long	YES
Debbie Ahearn		YES	Jamie Carden	YES
Thomas Doty	M	YES	Stan Harville	YES
Wayne NeSmith		NO	Peggy Howell	YES
Mike Reed	S	YES	Bobby Haun	YES
Mike Richardson		ABSTAIN	Tim Horner	ABSENT
Kyle Walker		YES	Edna Greene	YES



Hamblen County Legislative Body Regularly Meeting
May 21, 2026

OpenMeeting



Morristown-Hamblen Library

417 WEST MAIN STREET, MORRISTOWN, TN 37814 TELEPHONE: 423-586-6410 / FAX: 423-587-

April 30, 2026

Chris Cutshaw, Mayor
Hamblen County Government
511 West Second North Street
Administrative Building, 1st floor
Morristown, TN 37814

Dear Mayor Cutshaw:

I am submitting the following nominee on behalf of the Hamblen County Library Board of Trustees for your consideration of Board representatives beginning immediately:

Mike Richardson, 2991 Boatman's Mountain Road, Morristown, TN 37814 to begin his first full term as County representative on July 1, 2026. He has stepped in to replace resigning board member, Stan Harville , 1125 Springvale Road, Morristown, TN 37813 (December 2025) and has been nominated to start his first full term on April 28, 2026.

Sincerely,

Amanda Baysinger,
Interim Director

May 21, 2026

[Return to Regular Calendar](#)

APPROVAL OF CONSENT CALENDAR ITEMS ADDITION

Motion by Stan Harville, seconded by Kyle Walker to approve the addition item 12-HCBOE Formal Bid for USABLE and American Fidelity 420,000 Basic Life Insurance Cost-Finance Department to the consent calendar items.

VOTING FOR:

Debbie A'Hearn
Jamie Carden
Thomas Doty
Edna Greene
Stan Harville
Bobby Haun
Peggy Howell
Rodney Long
Mike Reed
Mike Richardson
Wayne NeSmith
Kyle Walker

Voting Against:

None

Absent:

Joe Huntsman
Tim Horner

Motion Passed.

APPROVAL OF CONSENT CALENDAR ITEMS WITH ADDITIONS

Motion by Stan Harville, seconded by Kyle Walker to approve Consent Calendar Items.

VOTING FOR:

Debbie A'Hearn

Jamie Carden

Thomas Doty

Edna Greene

Stan Harville

Bobby Haun

Peggy Howell

Rodney Long

Mike Reed

Mike Richardson

Wayne NeSmith

Kyle Walker

Voting Against:

None

Absent:

Joe Huntsman

Tim Horner

Motion Passed.

4.a. (4.a. was on the board, vote screen was lost when clerk went back after off board vote to add to consent calendar was started on vote screen instead of off the board)

CERTIFICATE OF ELECTION OF NOTARIES PUBLIC
AS A CLERK OF THE COUNTY OF HAMBLEN, TENNESSEE I HEREBY CERTIFY TO
THE SECRETARY OF STATE THAT THE FOLLOWING WERE ELECTED TO THE OFFICE OF
NOTARY PUBLIC DURING THE MAY 21, 2026 MEETING OF THE GOVERNING BODY:

NAME	HOME ADDRESS	HOME PHONE	BUSINESS ADDRESS	BUSINESS PHONE	SURETY
1. MEGAN D COATS	2476 TARR RD TALBOTT TN 378773001	423-608-9386	918 W 1ST NORTH ST MORRISTOWN TN 378144550	423-586-5291	
2. KRISTEN FAITH COOK	634 RIPPETOE AVE MORRISTOWN TN 378132559	423-714-1773	120 EVANS AVE MORRISTOWN TN 378146622	--	
3. AHMAD FULTON	3606 CARLYLE PLACE MORRISTOWN TN 37814	423-231-5900	4470 BROCKWOOD DR MORRISTOWN TN 37813	2319074	
4. VERONICA GALVAN	1423 LAKEVIEW CIR MORRISTOWN TN 378143025	423-277-3621	296 S DAISY ST. MORRISTOWN TN 378132309	--	
5. ANGELA GARLAND	906 LLOYD ST MORRISTOWN TN 378144313	423-312-7391	221 E MAIN ST MORRISTOWN TN 378144730	423-586-7613	
6. AMY Y GUINN	1602 MEDLIN RD MORRISTOWN TN 378144344	423-312-5530	840 W 1ST NORTH ST MORRISTOWN TN 37814	423-587-6898	STATE FARM
7. KATIE ELIZABETH HAMMONDS	1100 ISENBURG LN MOORESBERG TN 378115341	740-704-6788	711 W FIRST NORTH ST MORRISTOWN TN 37814	--	
8. MARTINA ANNE HOFFA	740 PANTHER CREEK RD MORRISTOWN TN 378141546	423-616-3031	3889 WONDERLAND LN SEVIERVILLE TN 378628288	--	
9. TAMERA DAWN KIMBROUGH	3185 RAMONA CIR MORRISTOWN TN 37813	423-248-4327	662 E. BROADWAY BLVD JEFFERSON CITY TN 37760	865-544-5400	
10. JUDITH ROBERTS LYKENS	5132 CRYSTAL BROOK DR MORRISTOWN TN 378141597	423-312-2218	1730 W ANDREW JOHNSON HWY MORRISTOWN TN 378143737	423-581-2880	\$10,000
11. JILL L MARGELOWSKY	1675 THREE SPRINGS RD RUSSELLVILLE TN 37860	423-587-3266	511 W 2ND NORTH ST MORRISTOWN TN 37814	423-589-6290	STRATE INSIRANCE
12. RAY BROOKLYN MARTIN	1232 WALTERS DR MORRISTOWN TN 378146138	865-562-5022	110 MED TECH PKWY JOHNSON CITY TN 376044004	--	
13. HEATHER NICOLE MCCLLOUD	2975 FISH HATCHERY RD MORRISTOWN TN 37813	770-241-9178	4310 WINKLER AVE MORRISTOWN TN 37814	865-544-5400	
14. ANTHONY MOON	2302 JOE STEPHENS RD MORRISTOWN TN 378141750	423-353-5023	110 HOSPITAL DR JEFFERSON CITY TN 377605281	--	NOTARY.NET
15. TONYA M POLIDORO	2325 KEETOOWAH TRL TALBOTT TN 378779089	423-312-2098	733 W MAIN ST MORRISTOWN TN 378144510	--	
16. WHITNEY RAMSEY	1233 SANDSTONE LANE DANDRIDGE TN 37725	423-415-9098	5327 WINNER CIRCLE RD MORRISTOWN TN 37813	865-544-5400	
17. JULIE B REX	294 SUNSET BLVD WHITE PINE TN 378904217	865-789-6129	1112 W 1ST NORTH ST MORRISTOWN TN 378144554	--	
18. AANISHAMA SINGH	2348 W AJ HWY MORRISTOWN TN 378143208	404-547-1187	2348 W AJ HWY MORRISTOWN TN 378143208	404-547-1187	
19. TERESA SAYLOR TEMPLIN	4120 DAN DR MORRISTOWN TN 378146769	423-307-7785	116 E MAIN ST MORRISTOWN TN 37815	423-586-5800	SAM NEILL INSURANCE
20. SHIRLEY S TRENT	2536 KIDWELL CHURCH RD MORRISTOWN TN 378141912	423-312-0950	12500 WEST CREEK PKWY RICHMOND VA 232381110	423-736-0516	

Batch: 184

Peggy Henderson
SIGNATURE

CLERK OF THE COUNTY OF HAMBLEN, TENNESSEE

5-11-26

DATE

Return to Regular Calendar

CERTIFICATE OF ELECTION OF NOTARIES PUBLIC
AS A CLERK OF THE COUNTY OF HAMBLÉN, TENNESSEE I HEREBY CERTIFY TO
THE SECRETARY OF STATE THAT THE FOLLOWING WERE ELECTED TO THE OFFICE OF
NOTARY PUBLIC DURING THE MAY 21, 2026 MEETING OF THE GOVERNING BODY:

NAME	HOME ADDRESS	HOME PHONE	BUSINESS ADDRESS	BUSINESS PHONE	SURETY
21. TAMMY VARGUEZ	1425 BUFFALO TRL MORRISTOWN TN 37814	423-258-6485	1425 BUFFALO TRL MORRISTOWN TN 37814	--	



May 21, 2026

RECEIVED
MAY 11 2026
OFFICE OF HAMBLÉN
COUNTY MAYOR

Reagy Henderson
SIGNATURE

CLERK OF THE COUNTY OF HAMBLÉN, TENNESSEE
5-11-26
DATE Return to Regular Calendar

Hamblen County Government
 Jail / Justice Center Project Expenditures
 As of April 30, 2026

Category of Costs	Description	Amount	Total Per Category
Moseley Architects			
Paid Prior to FY2021	Phase I and II & Design & Construction Planning Phase	\$ 943,700.00	
Paid in FY2021	Design & Construction Planning Phase	\$ 699,828.51	
Paid in FY2022	Design & Construction Planning Phase	\$ 3,114,662.02	
Paid in FY2023	Design & Construction Planning Phase	\$ 465,833.45	
Paid in FY2024	Design & Construction Planning Phase	\$ 356,908.88	
Paid in FY2025	Design & Construction Planning Phase	\$ 34,238.00	
			\$ 5,615,170.86
BurWil Construction			
Paid in FY2021	Project Management	\$ 283,597.96	
Paid in FY2022	Project Management	\$ 227,515.00	
Paid in FY2023	Project Management	\$ 313,002.65	
Paid in FY2024	Project Management	\$ 197,339.35	
Paid in FY2025	Project Management	\$ 43,025.41	
Paid in FY2026	Project Management	\$ 8,237.35	
			\$ 1,072,717.72
Blaine Construction			
Paid in FY2022	Construction	\$ 18,460,845.00	
Paid in FY2023	Construction	\$ 29,880,119.16	
Paid in FY2024	Construction	\$ 33,920,943.95	
Paid in FY2025	Construction	\$ 11,397,286.00	
Paid in FY2026	Construction	\$ 1,392,000.10	
			\$ 95,051,194.21
Entegrity Consulting			
Paid in FY2021	Commissioning Services	\$ 3,294.00	
Paid in FY2022	Commissioning Services	\$ 4,392.00	
Paid in FY2023	Commissioning Services	\$ 6,807.60	
			\$ 14,493.60
Property Acquisition			
Paid Prior to FY2021		\$ 1,250,751.07	
Paid in FY2021		\$ 895,659.17	
Paid in FY2022		\$ 1,326.52	\$ 2,147,736.76
FF&E Costs			
Paid in FY2024		\$ 60,759.34	
Paid in FY2025		\$ 967,925.18	
Paid in FY2026		\$ 232,158.49	\$ 1,260,843.01
Other Costs			
Paid Prior to FY2021	Site Preparation, Clearing, and Soil Testing and All Other Costs	\$ 109,649.17	
Paid in FY2021	Site Preparation, Clearing, and Soil Testing and All Other Costs	\$ 169,962.00	
Paid in FY2022	Site Preparation, Clearing, and Soil Testing and All Other Costs	\$ 122,120.00	
Paid in FY2023	Site Preparation, Clearing, and Soil Testing and All Other Costs	\$ 159,112.50	
Paid in FY2024	Site Preparation, Clearing, and Soil Testing and All Other Costs	\$ 46,855.00	
Paid in FY2025	Site Preparation, Clearing, and Soil Testing and All Other Costs	\$ 12,297.50	
9/29/2022	MUS - Tap & Impact Fees for Jail Connections	\$ 54,000.00	
Paid in FY2023	Deacon Foodservice Solutions	\$ 251,563.81	
Paid in FY2024	Deacon Foodservice Solutions	\$ 206,792.19	
Paid in FY2025	Deacon Foodservice Solutions	\$ 34,683.43	
1/12/2023	TN Dept of Environment & Conservation - Storm Water Annual Fee	\$ 500.00	
1/4/2024	Professional Svcs - Bond Compliance Specialists	\$ 2,650.00	
1/11/2024	TN Dept of Environment & Conservation - Storm Water Annual Fee	\$ 500.00	
FY 24-25	Professional Svcs - Bond Compliance Specialists	\$ 1,775.00	
FY 25-26	Professional Svcs - Bond Compliance Specialists	\$ 650.00	
FY 25-26	Inspection Fees	\$ 27,613.00	
			\$ 1,200,723.60
Total Expenditures on Jail / Justice Center Project			\$ 106,362,879.76

May 21, 2026

[Return to Regular Calendar](#)

EXPENDITURE REPORTS

EXPENSE SUMMARY REPORT

April 2025-2026

HAMBLEN COUNTY ACCOUNTS & BUDGETS

Fund(s) Selected:

101 General Fund

101

Account Group	Budget Amount	Budget Amendments	Amended Budget	MTD Expenses	YTD Expenses	Outstanding Encumbrances	Unencumbered Balance	% Bdg't Remain
51100 County Commission	202,376.00	0.00	202,376.00	10,743.01	130,041.20	28,408.88	43,925.92	21.71%
51210 Board Of Equalization	8,350.00	0.00	8,350.00	0.00	0.00	0.00	8,350.00	100.00%
51300 County Mayor/Executive	275,305.00	0.00	275,305.00	22,282.68	219,597.47	6,378.25	49,329.28	17.92%
51400 County Attorney	36,303.00	0.00	36,303.00	7,698.91	20,518.60	0.00	15,784.40	43.48%
51500 Election Commission	433,615.00	0.00	433,615.00	27,661.14	296,941.54	10,488.43	126,185.03	29.10%
51600 Register Of Deeds	474,656.00	0.00	474,656.00	41,940.67	356,510.63	7,330.77	110,814.60	23.35%
51720 Planning	289,961.00	0.00	289,961.00	16,156.71	192,217.69	2,651.88	95,091.43	32.79%
51750 Codes Compliance	73,552.00	0.00	73,552.00	6,236.37	55,836.64	0.00	17,715.36	24.09%
51760 Geographical Information Systems	108,603.00	0.00	108,603.00	5,740.74	83,985.31	0.00	24,617.69	22.67%
51810 Other Facilities	1,247,270.00	25,800.00	1,273,070.00	111,522.94	920,953.27	27,111.07	325,005.66	25.53%
51900 Other General Administration	16,500.00	0.00	16,500.00	0.00	11,500.00	0.00	5,000.00	30.30%
51910 Preservation Of Records	25,709.00	0.00	25,709.00	1,923.65	18,225.37	893.06	6,590.57	25.64%
52100 Accounting And Budgeting	656,992.00	29,235.00	686,227.00	144,727.81	584,352.55	608.47	101,265.98	14.76%
52300 Property Assessor's Office	447,079.00	0.00	447,079.00	35,849.10	353,642.84	3,723.98	89,712.18	20.07%
52310 Reappraisal Program	184,519.00	0.00	184,519.00	11,996.33	51,358.23	236.88	132,923.89	72.04%
52400 County Trustee's Office	464,867.00	0.00	464,867.00	37,719.22	366,068.86	2,832.31	95,965.83	20.64%
52500 County Clerk's Office	1,028,755.00	3,000.00	1,031,755.00	72,173.08	733,906.69	12,284.62	285,563.69	27.68%
52600 Data Processing	193,417.00	47,416.08	240,833.08	18,098.48	137,505.94	44,548.02	58,779.12	24.41%
53100 Circuit Court	1,239,689.00	3,400.00	1,243,089.00	93,229.27	948,152.34	5,299.98	289,636.68	23.30%
53300 General Sessions Court	757,798.00	37,835.00	795,633.00	68,971.38	605,323.36	1,032.92	189,276.72	23.79%
53330 Drug Court	235,664.00	18,905.96	254,569.96	26,607.61	189,053.56	2,256.06	63,260.34	24.85%
53400 Chancery Court	469,279.00	0.00	469,279.00	31,128.01	331,551.11	15,488.18	122,239.71	26.05%
53500 Juvenile Court	409,075.00	0.00	409,075.00	27,374.65	247,003.23	2,719.94	159,351.83	38.95%
53900 Other Admin Of Justice - Mental Health	186,830.00	0.00	186,830.00	6,240.54	93,775.95	7,559.43	85,494.62	45.76%

EXPENSE SUMMARY REPORT

April 2025-2026

HAMBLÉN COUNTY ACCOUNTS & BUDGETS

Fund(s) Selected:

101 General Fund

101

Account Group	Budget Amount	Budget Amendments	Amended Budget	MTD Expenses	YTD Expenses	Outstanding Encumbrances	Unencumbered Balance	% Bdgt Remain
53910 Probation Services	326,556.00	0.00	326,556.00	23,023.06	220,282.62	295.31	105,978.07	32.45%
53920 Courtroom Security	1,435,218.00	6,000.00	1,441,218.00	111,529.55	1,099,001.20	16,815.85	325,400.95	22.58%
53930 Victim Assistance Program	0.00	0.00	0.00	0.00	0.00	0.00	0.00	
54110 Sheriff's Department	6,247,531.00	-1,606,058.38	4,641,472.62	318,469.58	3,173,345.85	173,614.42	1,294,512.35	27.89%
54120 Special Patrols	0.00	1,677,080.07	1,677,080.07	149,060.09	1,659,578.98	0.00	17,501.09	1.04%
54160 Administration Of The Sexual Offender	6,750.00	0.00	6,750.00	1,371.99	5,277.10	0.00	1,472.90	21.82%
54210 Jail	9,005,240.00	25,451.81	9,030,691.81	714,546.19	6,271,469.02	281,544.29	2,477,678.50	27.44%
54220 Workhouse	131,309.00	0.00	131,309.00	5,043.58	49,876.06	0.00	81,432.94	62.02%
54250 Work Release Program	458,287.00	0.00	458,287.00	19,734.03	196,884.05	3,985.52	257,417.43	56.17%
54310 Fire Prevention And Control	300,000.00	0.00	300,000.00	150,000.00	300,000.00	0.00	0.00	0.00%
54410 Civil Defense	167,667.00	0.00	167,667.00	14,529.02	134,237.70	3,631.43	29,797.87	17.77%
54490 Other Emergency Management	334,880.00	0.00	334,880.00	141,580.00	344,644.00	0.00	-9,764.00	-2.92%
54510 Inspection And Regulation	6,844.00	0.00	6,844.00	484.44	4,844.40	0.00	1,999.60	29.22%
54610 Medical Examiner	247,540.00	0.00	247,540.00	9,078.99	106,910.95	8,291.76	132,337.29	53.46%
54710 Drug Court Expansion - Public Safety Grant	366,437.00	0.00	366,437.00	34,752.70	229,474.27	74,683.83	62,278.90	17.00%
54900 Other Public Safety	24,000.00	0.00	24,000.00	454.00	15,454.00	0.00	8,546.00	35.61%
55110 Local Health Center	1,477,888.00	0.00	1,477,888.00	67,157.07	679,535.35	10,961.90	787,390.75	53.28%
55120 Rabies And Animal Control	457,369.00	0.00	457,369.00	36,539.88	366,683.13	2,980.31	87,705.56	19.18%
55140 Nursing Home	7,000.00	0.00	7,000.00	0.00	7,000.00	0.00	0.00	0.00%
55170 Alcohol And Drug Programs	6,400.00	0.00	6,400.00	0.00	6,400.00	0.00	0.00	0.00%
55390 Appropriation To State	115,233.00	0.00	115,233.00	0.00	0.00	0.00	115,233.00	100.00%
55520 Aid To Dependent Children	10,000.00	0.00	10,000.00	0.00	10,000.00	0.00	0.00	0.00%
55590 Other Local Welfare Services	27,700.00	0.00	27,700.00	0.00	26,190.00	0.00	1,510.00	5.45%
55710 Sanitation Management	21,710.00	0.00	21,710.00	0.00	105.86	0.00	21,604.14	99.51%

EXPENSE SUMMARY REPORT

April 2025-2026

HAMBLLEN COUNTY ACCOUNTS & BUDGETS 101 General Fund

Fund(s) Selected:
101

Account Group	Budget Amount	Budget Amendments	Amended Budget	MTD Expenses	YTD Expenses	Outstanding Encumbrances	Unencumbered Balance	% Bdgt Remain
55900 Other Public Health And Welfare	95,000.00	0.00	95,000.00	0.00	42,178.11	0.00	52,821.89	55.60%
56100 Adult Activities	11,600.00	0.00	11,600.00	0.00	11,600.00	0.00	0.00	0.00%
56300 Senior Citizens Assistance	6,500.00	0.00	6,500.00	0.00	6,500.00	0.00	0.00	0.00%
56500 Libraries	386,000.00	0.00	386,000.00	0.00	289,500.00	0.00	96,500.00	25.00%
56700 Parks And Fair Boards	370,681.00	57,320.90	428,001.90	24,855.17	259,207.23	61,444.29	107,350.38	25.08%
56900 Other Social, Cultural And Recreational	271,000.00	0.00	271,000.00	75,000.00	271,000.00	0.00	0.00	0.00%
57100 Agricultural Extension Service	232,544.00	0.00	232,544.00	8,055.18	104,445.07	5,500.00	122,598.93	52.72%
57300 Forest Service	1,000.00	0.00	1,000.00	0.00	1,000.00	0.00	0.00	0.00%
57500 Soil Conservation	93,614.00	0.00	93,614.00	7,590.30	75,009.71	0.00	18,604.29	19.87%
57800 Storm Water Management	94,744.00	0.00	94,744.00	6,989.98	66,041.69	7,947.32	20,754.99	21.91%
58110 Tourism	77,500.00	0.00	77,500.00	37,750.00	84,357.24	18,040.86	-24,898.10	-32.13%
58120 Industrial Development	698,000.00	0.00	698,000.00	40,500.00	649,590.67	0.00	48,409.33	6.94%
58190 Other Economic And Community D	0.00	0.00	0.00	0.00	165,734.49	0.00	-165,734.49	
58300 Veterans' Services	41,455.00	0.00	41,455.00	3,138.62	30,417.18	28.82	11,009.00	26.56%
58600 Employee Benefits	1,091,844.00	0.00	1,091,844.00	464.85	858,338.05	0.00	233,505.95	21.39%
58900 Miscellaneous	386,300.00	0.00	386,300.00	0.00	491,718.47	62,000.00	-167,418.47	-43.34%
73300 Community Services	5,000.00	0.00	5,000.00	0.00	5,000.00	0.00	0.00	0.00%
91110 General Administration Projects	342,000.00	250,310.00	592,310.00	0.00	390,778.20	0.00	201,531.80	34.02%
91120 Administration Of Justice Projects	0.00	0.00	0.00	0.00	0.00	0.00	0.00	
91130 Public Safety Projects	114,000.00	0.00	114,000.00	0.00	114,002.20	57,051.61	-57,053.81	-50.05%
91140 Public Health And Welfare Projects	0.00	0.00	0.00	260,510.15	3,421,183.67	43,099.00	-3,464,282.67	
91150 Social, Cultural And Recreation Projects	30,000.00	7,875.00	37,875.00	0.00	0.00	36,536.00	1,339.00	3.54%
91190 Other General Government Proje	85,000.00	0.00	85,000.00	0.00	0.00	0.00	85,000.00	100.00%
91200 Highway And Street Capital Projects	0.00	0.00	0.00	0.00	0.00	0.00	0.00	

May 21, 2026

EXPENSE SUMMARY REPORT

April 2025-2026

HAMBLEEN COUNTY ACCOUNTS & BUDGETS

101 General Fund

Fund(s) Selected:

101

Account Group	Budget Amount	Budget Amendments	Amended Budget	MTD Expenses	YTD Expenses	Outstanding Encumbrances	Unencumbered Balance	% Bdgt Remain
99100 Transfers Out	600,000.00	0.00	600,000.00	52,660.60	652,660.60	0.00	-52,660.60	-8.78%
General Fund #(101)	<u>35,681,505.00</u>	<u>583,571.44</u>	<u>36,265,076.44</u>	<u>3,140,891.32</u>	<u>29,845,479.50</u>	<u>1,050,305.65</u>	<u>5,369,291.29</u>	<u>14.81%</u>

May 21, 2026

EXPENSE SUMMARY REPORT

April 2025-2026

HAMBLEEN COUNTY ACCOUNTS & BUDGETS

Fund(s) Selected:

116 Sanitation

116

Account Group	Budget Amount	Budget Amendments	Amended Budget	MTD Expenses	YTD Expenses	Outstanding Encumbrances	Unencumbered Balance	% Bdgt Remain
55710 Sanitation Management	4,522,964.00	50,002.20	4,572,966.20	308,588.29	3,062,552.01	204,757.03	1,305,657.16	28.55%
99100 Transfers Out	0.00	0.00	0.00	0.00	0.00	0.00	0.00	
Solid Waste/Sanitation Fund #(116)	4,522,964.00	50,002.20	4,572,966.20	308,588.29	3,062,552.01	204,757.03	1,305,657.16	28.55%

May 21, 2026

EXPENSE SUMMARY REPORT

April 2025-2026

HAMBLEEN COUNTY ACCOUNTS & BUDGETS

131 Highway

Fund(s) Selected:
131

Account Group	Budget Amount	Budget Amendments	Amended Budget	MTD Expenses	YTD Expenses	Outstanding Encumbrances	Unencumbered Balance	% Bdgt Remain
61000 Administration	519,228.00	0.00	519,228.00	30,072.28	412,317.70	10,117.18	96,793.12	18.64%
62000 Highway And Bridge Maintenance	1,941,456.00	0.00	1,941,456.00	115,479.39	1,164,235.59	74,706.23	702,514.18	36.18%
63100 Operation And Maintenance Of Equipment	657,793.00	0.00	657,793.00	30,852.70	295,590.51	175,215.67	186,986.82	28.43%
66000 Employee Benefits	25,931.00	0.00	25,931.00	0.00	22,368.71	0.00	3,562.29	13.74%
68000 Capital Outlay	29,500.00	0.00	29,500.00	1,760.00	2,393.00	0.00	27,107.00	91.89%
99100 Transfers Out	0.00	0.00	0.00	0.00	0.00	0.00	0.00	
Highway/Public Works Fund (#131)	3,173,908.00	0.00	3,173,908.00	178,164.37	1,896,905.51	260,039.08	1,016,963.41	32.04%

May 21, 2026

REVENUE SUMMARY REPORTS

May 21, 2026

[Return to Regular Calendar](#)

REVENUE SUMMARY REPORT

April 2025-2026

HAMBLEN COUNTY ACCOUNTS & BUDGETS

101 General Fund

Fund(s) Selected:
101; 122; 128; 151; 154;
171; 173; 176; 177; 178;

Fd	Acct	Obj	Loc	Prg	Description	Budget Amount	Budget Amendments	Amended Budget	MTD Revenues	YTD Revenues	Uncollected Revenues	% of Bdt
10	40110	000	00000	000	Current Property Tax	20,332,479.00	0.00	20,332,479.00	0.00	20,208,001.60	124,477.40	99.38%
10	40115	000	00000	000	Discount On Property Taxes	607,000.00	0.00	607,000.00	0.00	0.00	607,000.00	0.000%
10	40120	000	00000	000	Trustee's Collections - Prior Year	260,000.00	0.00	260,000.00	0.00	362,795.41	-102,795.41	139.5%
10	40125	000	00000	000	Trustee Collections - Bankruptcy	1,200.00	0.00	1,200.00	0.00	2,896.86	-1,696.86	241.4%
10	40130	000	00000	000	Circuit Clerk/Clerk & Master Collections-Prior Yrs	75,000.00	0.00	75,000.00	0.00	33,259.29	41,740.71	44.34%
10	40140	000	00000	000	Interest And Penalty	85,000.00	0.00	85,000.00	0.00	71,540.06	13,459.94	84.16%
10	40161	000	00000	000	Payments In Lieu Of Taxes - T.V.A.	1,234.00	0.00	1,234.00	0.00	0.00	1,234.00	0.000%
10	40162	000	00000	000	Payments In Lieu Of Taxes - Local Utilities	173,000.00	0.00	173,000.00	0.00	178,745.86	-5,745.86	103.3%
10	40163	000	00000	000	Payments In Lieu Of Taxes - Other	60,000.00	0.00	60,000.00	0.00	64,179.26	-4,179.26	106.9%
10	40210	000	00000	000	Local Option Sales Tax	17,000.00	0.00	17,000.00	0.00	11,821.84	5,178.16	69.54%
10	40220	000	00000	000	Hotel/Motel Tax	19,000.00	0.00	19,000.00	0.00	19,785.06	-785.06	104.1%
10	40240	000	00000	000	Wheel Tax	0.00	0.00	0.00	0.00	0.00	0.00	100.0%
10	40250	000	00000	000	Litigation Tax - General	120,000.00	0.00	120,000.00	0.00	0.00	120,000.00	0.000%
10	40250	000	05310	000	Litigation Tax - General - Circuit Court One (1)	0.00	0.00	0.00	0.00	7,446.61	-7,446.61	100.0%
10	40250	000	05330	000	Litigation Tax - General - General Sessions One (1)	0.00	0.00	0.00	0.00	89,843.68	-89,843.68	100.0%
10	40250	000	05340	000	Litigation Tax - General - Chancery Court	0.00	0.00	0.00	0.00	8,858.74	-8,858.74	100.0%
10	40260	000	00000	000	Litigation Tax - Special Purpose	60,000.00	0.00	60,000.00	0.00	46,895.84	13,104.16	78.15%
10	40266	000	05310	000	Litigation Tax - Jail, Workhouse, or Courthouse - Circuit	0.00	0.00	0.00	0.00	3,067.91	-3,067.91	100.0%
10	40268	000	00000	000	Litigation Tax - Courthouse Security	120,000.00	0.00	120,000.00	0.00	0.00	120,000.00	0.000%
10	40268	000	05310	000	Litigation Tax - Courthouse Security - Circuit Court One	0.00	0.00	0.00	0.00	0.00	0.00	100.0%
10	40268	000	05330	000	Litigation Tax - Courthouse Security - General Sessions	0.00	0.00	0.00	0.00	95,619.95	-95,619.95	100.0%
10	40268	000	05340	000	Litigation Tax - Courthouse Security - Chancery Court	0.00	0.00	0.00	0.00	5,066.92	-5,066.92	100.0%
10	40270	000	00000	000	Business Tax	1,550,000.00	0.00	1,550,000.00	0.00	431,931.69	1,118,068.31	27.86%
10	40275	000	00000	000	Mixed Drink Tax	0.00	0.00	0.00	0.00	0.00	0.00	100.0%
10	40350	000	00000	000	Interstate Telecommunications Tax	0.00	0.00	0.00	0.00	0.00	0.00	100.0%
101 40--						23,480,913.	0.00	23,480,913.	0.00	21,641,756.	1,839,156.42	
10	41110	000	00000	000	Marriage Licenses	5,000.00	0.00	5,000.00	0.00	3,610.00	1,390.00	72.20%

REVENUE SUMMARY REPORT

April 2025-2026

HAMBLLEN COUNTY ACCOUNTS & BUDGETS

101 General Fund

Fund(s) Selected:
101; 122; 128; 151; 154;
171; 173; 176; 177; 178;

Fd	Acct	Obj	Loc	Prg	Description	Budget Amount	Budget Amendments	Amended Budget	MTD Revenues	YTD Revenues	Uncollected Revenues	% of Bdgt
10	41140	000	00000	000	Cable TV Franchise	200,000.00	0.00	200,000.00	0.00	156,882.94	43,117.06	78.44%
10	41520	000	00000	000	Building Permits	150,000.00	0.00	150,000.00	0.00	131,183.55	18,816.45	87.45%
			101	41---		355,000.00	0.00	355,000.00	0.00	291,676.49	63,323.51	
10	42110	000	00000	000	Fines	4,000.00	0.00	4,000.00	0.00	3,755.31	244.69	93.88%
10	42120	000	00000	000	Officers Costs	16,000.00	0.00	16,000.00	0.00	12,339.47	3,660.53	77.12%
10	42140	000	00000	000	Drug Control Fines	10,000.00	0.00	10,000.00	0.00	12,437.86	-2,437.86	124.3%
10	42141	000	00000	000	Drug Court Fees	2,000.00	0.00	2,000.00	0.00	2,299.32	-299.32	114.9%
10	42150	000	00000	000	Jail Fees	400.00	0.00	400.00	0.00	7.84	392.16	1.960%
10	42180	000	00000	000	DUI Treatment Fines	1,000.00	0.00	1,000.00	0.00	950.00	50.00	95.00%
10	42190	000	00000	000	Data Entry Fee - Circuit Court	3,500.00	0.00	3,500.00	0.00	2,850.08	649.92	81.43%
10	42310	000	00000	000	Fines	25,000.00	0.00	25,000.00	0.00	17,821.92	7,178.08	71.28%
10	42311	000	00000	000	Fines For Littering	0.00	0.00	0.00	0.00	47.50	-47.50	100.0%
10	42320	000	00000	000	Officers Costs	48,000.00	0.00	48,000.00	0.00	46,023.74	1,976.26	95.88%
10	42330	000	00000	000	Game And Fish Fines	100.00	0.00	100.00	0.00	569.25	-469.25	569.2%
10	42340	000	00000	000	Drug Control Fines	0.00	0.00	0.00	0.00	0.00	0.00	100.0%
10	42341	000	00000	000	Drug Court Fees	10,000.00	0.00	10,000.00	0.00	8,367.56	1,632.44	83.67%
10	42350	000	00000	000	Jail Fees	30,000.00	0.00	30,000.00	0.00	21,278.90	8,721.10	70.92%
10	42351	000	00000	000	Interpreter Fee	0.00	0.00	0.00	0.00	11.87	-11.87	100.0%
10	42380	000	00000	000	DUI Treatment Fines	7,000.00	0.00	7,000.00	0.00	3,755.11	3,244.89	53.64%
10	42390	000	00000	000	Data Entry Fee - General Sessions Court	20,000.00	0.00	20,000.00	0.00	19,149.00	851.00	95.74%
10	42391	000	00000	000	Courtroom Security Fee	500.00	0.00	500.00	0.00	595.21	-95.21	119.0%
10	42410	000	00000	000	Fines	1,000.00	0.00	1,000.00	0.00	408.00	592.00	40.80%
10	42420	000	00000	000	Officers Costs	6,000.00	0.00	6,000.00	0.00	7,668.40	-1,668.40	127.8%
10	42440	000	00000	000	Drug Control Fines	2,000.00	0.00	2,000.00	0.00	1,652.00	348.00	82.60%
10	42450	000	00000	000	Jail Fees	0.00	0.00	0.00	0.00	0.00	0.00	100.0%
10	42451	000	00000	000	Interpreter Fee	200.00	0.00	200.00	0.00	0.00	200.00	0.000%
10	42490	000	00000	000	Data Entry Fee - Juvenile Court	1,500.00	0.00	1,500.00	0.00	998.00	502.00	66.53%

REVENUE SUMMARY REPORT

April 2025-2026

HAMBLEN COUNTY ACCOUNTS & BUDGETS 101 General Fund

Fund(s) Selected:
101; 122; 128; 151; 154;
171; 173; 176; 177; 178;

Fd	Acct	Obj	Loc	Prg	Description	Budget Amount	Budget Amendments	Amended Budget	MTD Revenues	YTD Revenues	Uncollected Revenues	% of Bdgt
10	42491	000	00000	000	Courtroom Security Fee	0.00	0.00	0.00	0.00	0.00	0.00	100.0%
10	42520	000	00000	000	Officers Costs	0.00	0.00	0.00	0.00	0.00	0.00	100.0%
10	42530	000	00000	000	Data Entry Fee-Chancery Court	7,000.00	0.00	7,000.00	0.00	3,882.00	3,118.00	55.45%
10	42641	000	00000	000	Drug Court Fees	13,000.00	5,500.00	18,500.00	0.00	22,740.50	-4,240.50	122.9%
10	42641	000	02008	000	Drug Court Fees - Testing Of Outside Entities	0.00	0.00	0.00	0.00	963.00	-963.00	100.0%
10	42910	000	00000	000	Proceeds From Confiscated Property	0.00	0.00	0.00	0.00	0.00	0.00	100.0%
10	42990	000	00000	000	Other Fines, Forfeitures, And Penalties	100.00	0.00	100.00	0.00	75.50	24.50	75.50%
101 42---						208,300.00	5,500.00	213,800.00	0.00	190,647.34	23,152.66	
10	43102	000	00000	000	Other Employee Benefit Charges/Contributions	0.00	0.00	0.00	0.00	0.00	0.00	100.0%
10	43102	000	01080	000	Other Employee Benefit Charges/Contributions - Solid	0.00	0.00	0.00	0.00	0.00	0.00	100.0%
10	43102	000	01085	000	Other Employee Benefit Charges/Contributions - E-911	0.00	0.00	0.00	0.00	0.00	0.00	100.0%
10	43120	000	00000	000	Patient Charges	16,000.00	0.00	16,000.00	0.00	13,439.60	2,560.40	83.99%
10	43170	000	00000	000	Work Release Charges For Board	0.00	0.00	0.00	0.00	144.00	-144.00	100.0%
10	43340	000	00000	000	Recreation Fees	140,000.00	0.00	140,000.00	0.00	118,566.25	21,433.75	84.69%
10	43350	000	00000	000	Copy Fees	8,000.00	0.00	8,000.00	0.00	106.42	7,893.58	1.330%
10	43350	000	05160	000	Copy Fees - Register Of Deeds	0.00	0.00	0.00	0.00	390.35	-390.35	100.0%
10	43350	000	05170	000	Copy Fees - Planning And Zoning	0.00	0.00	0.00	0.00	0.00	0.00	100.0%
10	43350	000	05191	000	Copy Fees - Archives	0.00	0.00	0.00	0.00	0.00	0.00	100.0%
10	43350	000	05230	000	Copy Fees - Assessor Of Property/Reapprais	0.00	0.00	0.00	0.00	0.00	0.00	100.0%
10	43350	000	05250	000	Copy Fees - County Clerk	0.00	0.00	0.00	0.00	7,028.68	-7,028.68	100.0%
10	43366	000	00000	000	Greenbelt Late Application Fee	0.00	0.00	0.00	0.00	0.00	0.00	100.0%
10	43370	000	00000	000	Telephone Commissions	31,000.00	0.00	31,000.00	0.00	55,172.03	-24,172.03	177.9%
10	43380	000	00000	000	Vending Machine Collections	0.00	0.00	0.00	0.00	9.98	-9.98	100.0%
10	43381	000	00000	000	Tourism Fees	26,700.00	0.00	26,700.00	0.00	25,000.00	1,700.00	93.63%
10	43382	000	00000	000	Electronic Citation Fees - General Sessions	100.00	0.00	100.00	0.00	4.00	96.00	4.000%
10	43383	000	00000	000	Additional Fees - Titling and Registration	75,000.00	0.00	75,000.00	0.00	53,967.00	21,033.00	71.95%
10	43390	000	00000	000	Constitutional Officers' Fees & Commissions	0.00	0.00	0.00	0.00	0.00	0.00	100.0%

REVENUE SUMMARY REPORT

April 2025-2026

HAMBLLEN COUNTY ACCOUNTS & BUDGETS

101 General Fund

Fund(s) Selected:
101; 122; 128; 151; 154;
171; 173; 176; 177; 178;

Fd	Acct	Obj	Loc	Prg	Description	Budget Amount	Budget Amendments	Amended Budget	MTD Revenues	YTD Revenues	Uncollected Revenues	% of Bdgt
10	43392	000	00000	000	Data Processing Fee - Register	16,000.00	0.00	16,000.00	0.00	13,226.00	2,774.00	82.66%
10	43393	000	00000	000	Probation Fees	1,000.00	0.00	1,000.00	0.00	518.57	481.43	51.85%
10	43394	000	00000	000	Data Processing Fee - Sheriff	8,000.00	0.00	8,000.00	0.00	442.70	7,557.30	5.533%
10	43394	000	05310	000	Data Processing Fee - Sheriff - Circuit Court One (1)	0.00	0.00	0.00	0.00	403.99	-403.99	100.0%
10	43394	000	05330	000	Data Processing Fee - Sheriff - General Sessions One	0.00	0.00	0.00	0.00	4,420.67	-4,420.67	100.0%
10	43395	000	00000	000	Sexual Offender Registration Fee - Sheriff	3,000.00	0.00	3,000.00	0.00	1,950.00	1,050.00	65.00%
10	43396	000	00000	000	Data Processing Fees - County Clerk	6,000.00	0.00	6,000.00	0.00	2,574.00	3,426.00	42.90%
10	43399	000	00000	000	Vehicle Insurance Coverage and Reinstatement Fees	29,000.00	0.00	29,000.00	0.00	15,360.00	13,640.00	52.96%
10	43582	000	00000	000	Community Service Fees - Adults	3,000.00	0.00	3,000.00	0.00	323.47	2,676.53	10.78%
10	43990	000	30001	000	Other Charges For Services - Supervision Fees	0.00	0.00	0.00	0.00	169,021.55	-169,021.55	100.0%
10	43990	000	30002	000	Other Charges For Services - IPS/Litter Fees	0.00	0.00	0.00	0.00	4,025.00	-4,025.00	100.0%
10	43990	000	30003	000	Other Charges For Services - Drug Screen Fees	0.00	0.00	0.00	0.00	400.00	-400.00	100.0%
10	43990	000	30004	000	Other Charges For Services - Other Fees Collected	0.00	0.00	0.00	0.00	0.00	0.00	100.0%
10	43990	000	00000	000	Other Charges For Services	200,000.00	0.00	200,000.00	0.00	0.00	200,000.00	0.000%
101 43---						562,800.00	0.00	562,800.00	0.00	486,494.26	76,305.74	
10	44110	000	00000	000	Investment Income	0.00	0.00	0.00	0.00	0.00	0.00	100.0%
10	44120	000	00000	000	Lease/Rentals	53,600.00	0.00	53,600.00	0.00	0.00	53,600.00	0.000%
10	44120	000	06100	000	Lease/Rentals - Pavilion/Shed Rental Fees	0.00	0.00	0.00	0.00	23,530.00	-23,530.00	100.0%
10	44120	000	06110	000	Lease/Rentals - Boat Dock Fees	0.00	0.00	0.00	0.00	4,700.00	-4,700.00	100.0%
10	44120	000	06130	000	Lease/Rentals - Archery Club Lease	0.00	0.00	0.00	0.00	0.00	0.00	100.0%
10	44120	000	09100	000	Lease/Rentals - State Health Dept (Tdec)	0.00	0.00	0.00	0.00	0.00	0.00	100.0%
10	44120	000	06120	000	Lease/Rentals - Trap Club Lease	0.00	0.00	0.00	0.00	0.00	0.00	100.0%
10	44120	000	06140	000	Lease/Rentals - Amphitheater Fees	0.00	0.00	0.00	0.00	80.00	-80.00	100.0%
10	44120	000	55110	000	Lease/Rentals - Health Department	0.00	0.00	0.00	0.00	26,040.04	-26,040.04	100.0%
10	44130	000	00000	000	Sale Of Materials And Supplies	0.00	0.00	0.00	0.00	0.00	0.00	100.0%
10	44131	000	00000	000	Commissary Sales	16,000.00	0.00	16,000.00	0.00	13,154.00	2,846.00	82.21%
10	44140	000	00000	000	Sale Of Maps	0.00	0.00	0.00	0.00	0.00	0.00	100.0%

REVENUE SUMMARY REPORT

April 2025-2026

HAMBLLEN COUNTY ACCOUNTS & BUDGETS

101 General Fund

Fund(s) Selected:
101; 122; 128; 151; 154;
171; 173; 176; 177; 178;

Fd	Acct	Obj	Loc	Prg Description	Budget Amount	Budget Amendments	Amended Budget	MTD Revenues	YTD Revenues	Uncollected Revenues	% of Bdgt
10	44140	000	05230	000 Sale Of Maps - Assessor Of Property/Reapprais	0.00	0.00	0.00	0.00	0.00	0.00	100.0%
10	44160	000	00000	000 Retirees' Insurance Payments	0.00	0.00	0.00	0.00	0.00	0.00	100.0%
10	44170	000	00000	000 Miscellaneous Refunds	50,000.00	25,676.81	75,676.81	0.00	120,879.85	-45,203.04	159.7%
10	44170	000	05150	000 Miscellaneous Refunds - Election Commission	0.00	0.00	0.00	0.00	910.90	-910.90	100.0%
10	44170	000	05250	000 Miscellaneous Refunds - County Clerk	0.00	0.00	0.00	0.00	27,439.10	-27,439.10	100.0%
10	44170	000	05414	028 Miscellaneous Refunds - Tax Enforcement	0.00	0.00	0.00	0.00	0.00	0.00	100.0%
10	44180	000	00000	000 Expenditure Credits	0.00	0.00	0.00	0.00	-50,203.66	50,203.66	100.0%
10	44530	000	00000	000 Sale Of Equipment	20,000.00	2,875.00	22,875.00	0.00	8,576.00	14,299.00	37.49%
10	44540	000	00000	000 Sale Of Property	0.00	0.00	0.00	0.00	0.00	0.00	100.0%
10	44560	000	00000	000 Damages Recovered From Individuals	0.00	0.00	0.00	0.00	14,900.00	-14,900.00	100.0%
10	44570	000	00000	000 Contributions & Gifts	0.00	0.00	0.00	0.00	0.00	0.00	100.0%
10	44990	000	00000	000 Other Local Revenues	2,000.00	0.00	2,000.00	-34.00	3,080.52	-1,080.52	154.0%
101 44---					141,600.00	28,551.81	170,151.81	-34.00	193,086.75	-22,934.94	
10	45180	000	00000	000 Register	0.00	0.00	0.00	0.00	0.00	0.00	100.0%
10	45510	000	00000	000 County Clerk	850,000.00	0.00	850,000.00	0.00	584,122.64	265,877.36	68.72%
10	45520	000	00000	000 Circuit Court Clerk	300,000.00	0.00	300,000.00	0.00	164,232.53	135,767.47	54.74%
10	45520	000	05310	000 Circuit Court Clerk - Circuit Court One (1)	0.00	0.00	0.00	0.00	81,306.58	-81,306.58	100.0%
10	45540	000	00000	000 General Sessions Court Clerk	625,000.00	0.00	625,000.00	0.00	315,883.04	309,116.96	50.54%
10	45540	000	05330	000 General Sessions Court Clerk - General Sessions	0.00	0.00	0.00	0.00	217,433.29	-217,433.29	100.0%
10	45550	000	00000	000 Clerk And Master	180,000.00	0.00	180,000.00	0.00	132,715.20	47,284.80	73.73%
10	45560	000	00000	000 Juvenile Court Clerk	40,000.00	0.00	40,000.00	0.00	24,884.55	15,115.45	62.21%
10	45580	000	00000	000 Register	290,000.00	0.00	290,000.00	0.00	226,827.26	63,172.74	78.21%
10	45590	000	00000	000 Sheriff	22,000.00	0.00	22,000.00	0.00	16,664.70	5,335.30	75.74%
10	45610	000	00000	000 Trustee	1,275,000.00	0.00	1,275,000.00	0.00	1,262,367.52	12,632.48	99.00%
101 45---					3,582,000.00	0.00	3,582,000.00	0.00	3,026,437.31	555,562.69	
10	46110	000	00000	000 Juvenile Services Program	9,000.00	0.00	9,000.00	0.00	4,500.00	4,500.00	50.00%

REVENUE SUMMARY REPORT

April 2025-2026

HAMBLEEN COUNTY ACCOUNTS & BUDGETS

101 General Fund

Fund(s) Selected:
101; 122; 128; 151; 154;
171; 173; 176; 177; 178;

Fd	Acct	Obj	Loc	Prg	Description	Budget Amount	Budget Amendments	Amended Budget	MTD Revenues	YTD Revenues	Uncollected Revenues	% of Bdgt
10	46170	000	00000	000	Solid Waste Grants	95,000.00	0.00	95,000.00	0.00	60,812.55	34,187.45	64.01%
10	46190	000	00000	000	Other General Government Grants	0.00	0.00	0.00	0.00	0.00	0.00	100.0%
10	46210	000	00000	000	Law Enforcement Training Programs	47,900.00	0.00	47,900.00	0.00	0.00	47,900.00	0.000%
10	46240	000	00000	000	School Resources Officer Grants	1,350,000.00	0.00	1,350,000.00	0.00	1,350,000.00	0.00	100.0%
10	46290	000	00000	000	Other Public Safety Grants	0.00	64,500.00	64,500.00	0.00	215,100.00	-150,600.00	333.4%
10	46300	000	00000	000	Health And Welfare Grants	0.00	0.00	0.00	0.00	0.00	0.00	100.0%
10	46310	000	00000	000	Health Department Programs	1,400,988.00	0.00	1,400,988.00	0.00	424,647.31	976,340.69	30.31%
10	46430	000	00000	000	Litter Program	47,700.00	0.00	47,700.00	0.00	41,906.62	5,793.38	87.85%
10	46820	000	00000	000	Income Tax	0.00	0.00	0.00	0.00	0.00	0.00	100.0%
10	46835	000	00000	000	Vehicle Certificate Of Title Fees	15,000.00	0.00	15,000.00	0.00	9,476.55	5,523.45	63.17%
10	46840	000	00000	000	Alcoholic Beverage Tax	115,000.00	0.00	115,000.00	0.00	90,078.06	24,921.94	78.32%
10	46851	000	00000	000	State Revenue Sharing - T.V.A.	810,000.00	0.00	810,000.00	0.00	366,330.14	443,669.86	45.22%
10	46852	000	00000	000	State Revenue - Telecommunications	53,000.00	0.00	53,000.00	0.00	35,815.83	17,184.17	67.57%
10	46855	000	00000	000	State Shared Sports Gaming Privilege Tax	65,000.00	0.00	65,000.00	0.00	61,248.51	3,751.49	94.22%
10	46915	000	00000	000	Contracted Prisoner Boarding	800,000.00	0.00	800,000.00	0.00	999,457.00	-199,457.00	124.9%
10	46925	000	00000	000	Hybrid/Electric Vehicle Registration Fee	0.00	0.00	0.00	0.00	0.00	0.00	100.0%
10	46960	000	00000	000	Registrar's Salary Supplement	15,164.00	0.00	15,164.00	0.00	7,582.00	7,582.00	50.00%
10	46980	000	00000	000	Other State Grants	666,437.00	57,320.90	723,757.90	0.00	347,400.05	376,357.85	47.99%
10	46990	000	00000	000	Other State Revenues	60,000.00	0.00	60,000.00	0.00	38,736.42	21,263.58	64.56%
101 46---						5,550,189.00	121,820.90	5,672,009.90	0.00	4,053,091.04	1,618,918.86	
10	47220	000	00000	000	Civil Defense Reimbursement	30,704.00	0.00	30,704.00	0.00	0.00	30,704.00	0.000%
10	47235	000	00000	000	Homeland Security Grants	24,000.00	0.00	24,000.00	0.00	21,400.82	2,599.18	89.17%
10	47301	000	00000	000	COVID-19 Grant #1 Election Funds	0.00	0.00	0.00	0.00	0.00	0.00	100.0%
10	47302	000	00000	000	COVID - Employer Rebate	0.00	0.00	0.00	0.00	0.00	0.00	100.0%
10	47303	000	00000	000	COVID-19 Grant #3 Cares Act	0.00	0.00	0.00	0.00	0.00	0.00	100.0%
10	47304	000	00000	000	COVID-19 Grant #3	0.00	0.00	0.00	0.00	0.00	0.00	100.0%
10	47305	000	00000	000	COVID-19 Grant #4	0.00	0.00	0.00	0.00	0.00	0.00	100.0%

REVENUE SUMMARY REPORT

April 2025-2026

HAMBLEN COUNTY ACCOUNTS & BUDGETS

101 General Fund

Fund(s) Selected:
101; 122; 128; 151; 154;
171; 173; 176; 177; 178;

Fd	Acct	Obj	Loc	Prg	Description	Budget Amount	Budget Amendments	Amended Budget	MTD Revenues	YTD Revenues	Uncollected Revenues	% of Bdgt
10	47590	000	00000	000	Other Federal Through State	5,000.00	0.00	5,000.00	0.00	156,478.28	-151,478.28	3129.0%
10	47590	000	06500	000	Other Federal Through State - Oak Tree Plaza	0.00	0.00	0.00	0.00	0.00	0.00	100.0%
10	47590	000	70013	000	Other Federal Through State - BRC - Boys & Girls Club	0.00	0.00	0.00	0.00	0.00	0.00	100.0%
10	47590	000	70014	000	Other Federal Through State - BRC - Girls Inc.	0.00	0.00	0.00	0.00	0.00	0.00	100.0%
10	47590	000	70015	000	Other Federal Through State - BRC - HOLA	0.00	0.00	0.00	0.00	8,222.74	-8,222.74	100.0%
10	47590	000	70016	000	Other Federal Through State - BRC - Library	0.00	0.00	0.00	0.00	2,116.60	-2,116.60	100.0%
10	47590	000	70017	000	Other Federal Through State - BRC - Senior Citizen	0.00	0.00	0.00	0.00	0.00	0.00	100.0%
10	47590	000	70018	000	Other Federal Through State - BRC - Stepping Out	0.00	0.00	0.00	0.00	0.00	0.00	100.0%
10	47590	000	70019	000	Other Federal Through State - BRC - Maint. Block	0.00	0.00	0.00	0.00	0.00	0.00	100.0%
10	47590	000	70021	000	Other Federal Through State - BRC - Capital Expenses	0.00	0.00	0.00	0.00	0.00	0.00	100.0%
10	47590	000	70022	000	Other Federal Through State - BRC - Admin	0.00	0.00	0.00	0.00	2,000.00	-2,000.00	100.0%
10	47590	000	70020	000	Other Federal Through State - BRC - Professional Fees	0.00	0.00	0.00	0.00	4,000.00	-4,000.00	100.0%
10	47990	000	00000	000	Other Direct Federal Revenue	24,000.00	0.00	24,000.00	0.00	5,709.12	18,290.88	23.78%
10	47990	000	04030	000	Other Direct Federal Revenue - Social Security	0.00	0.00	0.00	0.00	400.00	-400.00	100.0%
10	47990	000	80001	000	Other Direct Federal Revenue - SAMHSA Direct	0.00	0.00	0.00	0.00	156,608.07	-156,608.07	100.0%
10	47990	000	81001	000	Other Direct Federal Revenue - SAMHSA Indirect	0.00	0.00	0.00	0.00	33,733.00	-33,733.00	100.0%
101 47---						83,704.00	0.00	83,704.00	0.00	390,668.63	-306,964.63	
10	48130	000	00000	000	Contributions	0.00	0.00	0.00	0.00	0.00	0.00	100.0%
10	48140	000	00000	000	Contracted Services	320,000.00	0.00	320,000.00	0.00	217,361.44	102,638.56	67.92%
10	48610	000	00000	000	Donations	1,000.00	0.00	1,000.00	0.00	0.00	1,000.00	0.000%
10	48610	000	05191	000	Donations - Archives	0.00	0.00	0.00	0.00	213.26	-213.26	100.0%
10	48990	000	00000	000	Other	0.00	0.00	0.00	0.00	0.00	0.00	100.0%
101 48---						321,000.00	0.00	321,000.00	0.00	217,574.70	103,425.30	
10	49700	000	00000	000	Insurance Recovery	0.00	2,296.69	2,296.69	0.00	19,122.89	-16,826.20	832.6%
10	49800	000	00000	000	Transfers In	150,000.00	10,000.00	160,000.00	0.00	10,000.00	150,000.00	6.250%

REVENUE SUMMARY REPORT

April 2025-2026

HAMBLEN COUNTY ACCOUNTS & BUDGETS

101 General Fund

Fund(s) Selected:
101; 122; 128; 151; 154;
171; 173; 176; 177; 178;

Fd	Acct	Obj	Loc	Prg Description	Budget Amount	Budget Amendments	Amended Budget	MTD Revenues	YTD Revenues	Uncollected Revenues	% of Bdgt
				101 49--	150,000.00	12,296.69	162,296.69	0.00	29,122.89	133,173.80	
General Fund #(101) Totals:					34,435,506.	168,169.40	34,603,675.	-34.00	30,520,555.	4,083,119.41	

May 21, 2026

REVENUE SUMMARY REPORT

April 2025-2026

HAMBLLEN COUNTY ACCOUNTS & BUDGETS 101 General Fund

Fund(s) Selected:
101; 122; 128; 151; 154;
171; 173; 176; 177; 178;

Fd	Acct	Obj	Loc	Prg	Description	Budget Amount	Budget Amendments	Amended Budget	MTD Revenues	YTD Revenues	Uncollected Revenues	% of Bdg
12	42140	000	00000	000	Drug Control Fines	1,800.00	0.00	1,800.00	0.00	144.39	1,655.61	8.021%
12	42240	000	00000	000	Drug Control Fines	0.00	0.00	0.00	0.00	0.00	0.00	100.0%
12	42340	000	00000	000	Drug Control Fines	7,500.00	0.00	7,500.00	0.00	7,242.40	257.60	96.56%
12	42910	000	00000	000	Proceeds From Confiscated Property	10,000.00	0.00	10,000.00	0.00	15,357.00	-5,357.00	153.5%
12	42990	000	00000	000	Other Fines, Forfeitures, And Penalties	0.00	0.00	0.00	0.00	0.00	0.00	100.0%
					122 42--	19,300.00	0.00	19,300.00	0.00	22,743.79	-3,443.79	
12	44110	000	00000	000	Investment Income	10,000.00	0.00	10,000.00	0.00	10,344.66	-344.66	103.4%
12	44170	000	00000	000	Miscellaneous Refunds	0.00	0.00	0.00	0.00	0.00	0.00	100.0%
12	44530	000	00000	000	Sale Of Equipment	0.00	0.00	0.00	0.00	0.00	0.00	100.0%
12	44560	000	00000	000	Damages Recovered From Individuals	0.00	0.00	0.00	0.00	1,395.50	-1,395.50	100.0%
					122 44--	10,000.00	0.00	10,000.00	0.00	11,740.16	-1,740.16	
12	46980	000	00000	000	Other State Grants	0.00	0.00	0.00	0.00	0.00	0.00	100.0%
					122 46--	0.00	0.00	0.00	0.00	0.00	0.00	
12	47590	000	00000	000	Other Federal Through State	0.00	0.00	0.00	0.00	0.00	0.00	100.0%
12	47700	000	00000	000	Asset Forfeiture Funds	0.00	0.00	0.00	0.00	0.00	0.00	100.0%
					122 47--	0.00	0.00	0.00	0.00	0.00	0.00	
12	48130	000	00000	000	Contributions	0.00	0.00	0.00	0.00	0.00	0.00	100.0%
12	48610	000	00000	000	Donations	0.00	0.00	0.00	0.00	0.00	0.00	100.0%
12	48990	000	00000	000	Other	0.00	0.00	0.00	0.00	0.00	0.00	100.0%
					122 48--	0.00	0.00	0.00	0.00	0.00	0.00	
12	49700	000	00000	000	Insurance Recovery	0.00	0.00	0.00	0.00	0.00	0.00	100.0%

REVENUE SUMMARY REPORT

April 2025-2026

HAMBLEEN COUNTY ACCOUNTS & BUDGETS

101 General Fund

Fund(s) Selected:
101; 122; 128; 151; 154;
171; 173; 176; 177; 178;

Fd	Acct	Obj	Loc	Prg	Description	Budget Amount	Budget Amendments	Amended Budget	MTD Revenues	YTD Revenues	Uncollected Revenues	% of Bdgt
			122	49---		0.00	0.00	0.00	0.00	0.00	0.00	
Drug Control Fund #(122) Totals:						29,300.00	0.00	29,300.00	0.00	34,483.95	-5,183.95	

May 21, 2026

REVENUE SUMMARY REPORT

April 2025-2026

HAMBLEN COUNTY ACCOUNTS & BUDGETS

101 General Fund

Fund(s) Selected:
101; 122; 128; 151; 154;
171; 173; 176; 177; 178;

Fd	Acct	Obj	Loc	Prg Description	Budget Amount	Budget Amendments	Amended Budget	MTD Revenues	YTD Revenues	Uncollected Revenues	% of Bdg
12	44110	000	00000	000 Investment Income	0.00	0.00	0.00	0.00	63,999.54	-63,999.54	100.0%
12	44170	000	00000	000 Miscellaneous Refunds	0.00	0.00	0.00	0.00	0.00	0.00	100.0%
			128 44---		0.00	0.00	0.00	0.00	63,999.54	-63,999.54	
12	46845	000	00000	000 Opioid Settlement Funds	0.00	0.00	0.00	0.00	0.00	0.00	100.0%
			128 46---		0.00	0.00	0.00	0.00	0.00	0.00	
12	48990	000	00000	000 Other	0.00	0.00	0.00	0.00	0.00	0.00	100.0%
12	48991	000	00000	000 Opioid Subdivision Funds	0.00	0.00	0.00	0.00	197,179.44	-197,179.44	100.0%
			128 48---		0.00	0.00	0.00	0.00	197,179.44	-197,179.44	
49800	000	00000	000	Transfers In	0.00	0.00	0.00	0.00	0.00	0.00	100.0%
			128 49---		0.00	0.00	0.00	0.00	0.00	0.00	
Drug Use Abatement Fund Totals:					0.00	0.00	0.00	0.00	261,178.98	-261,178.98	

May 21, 2026

REVENUE SUMMARY REPORT

April 2025-2026

HAMBLEEN COUNTY ACCOUNTS & BUDGETS

101 General Fund

Fund(s) Selected:
101; 122; 128; 151; 154;
171; 173; 176; 177; 178;

Fd	Acct	Obj	Loc	Prg	Description	Budget Amount	Budget Amendments	Amended Budget	MTD Revenues	YTD Revenues	Uncollected Revenues	% of Bdgt
15	40110	000	00000	000	Current Property Tax	7,100,000.00	0.00	7,100,000.00	0.00	6,773,772.09	326,227.91	95.40%
15	40120	000	00000	000	Trustee's Collections - Prior Year	133,000.00	0.00	133,000.00	0.00	166,763.61	-33,763.61	125.3%
15	40125	000	00000	000	Trustee Collections - Bankruptcy	1,500.00	0.00	1,500.00	0.00	1,101.56	398.44	73.43%
15	40130	000	00000	000	Circuit Clerk/Clerk & Master Collections-Prior Yrs	39,000.00	0.00	39,000.00	0.00	16,825.26	22,174.74	43.14%
15	40140	000	00000	000	Interest And Penalty	43,000.00	0.00	43,000.00	0.00	35,172.60	7,827.40	81.79%
15	40161	000	00000	000	Payments In Lieu Of Taxes - T.V.A.	624.00	0.00	624.00	0.00	0.00	624.00	0.000%
15	40162	000	00000	000	Payments In Lieu Of Taxes - Local Utilities	105,000.00	0.00	105,000.00	0.00	59,938.21	45,061.79	57.08%
15	40163	000	00000	000	Payments In Lieu Of Taxes - Other	30,000.00	0.00	30,000.00	0.00	21,452.38	8,547.62	71.50%
15	40210	000	00000	000	Local Option Sales Tax	0.00	0.00	0.00	0.00	0.00	0.00	100.0%
15	40266	000	00000	000	Litigation Tax - Jail, Workhouse, or Courthouse	100,000.00	0.00	100,000.00	0.00	102,728.72	-2,728.72	102.7%
15	40320	000	00000	000	Bank Excise Tax	35,000.00	0.00	35,000.00	0.00	38,320.40	-3,320.40	109.4%
					151 40---	7,587,124.00	0.00	7,587,124.00	0.00	7,216,074.83	371,049.17	
15	42150	000	00000	000	Jail Fees	2,000.00	0.00	2,000.00	0.00	1,486.80	513.20	74.34%
15	42350	000	00000	000	Jail Fees	65,000.00	0.00	65,000.00	0.00	60,065.31	4,934.69	92.40%
					151 42---	67,000.00	0.00	67,000.00	0.00	61,552.11	5,447.89	
15	44110	000	00000	000	Investment Income	1,800,000.00	0.00	1,800,000.00	98.94	1,101,635.83	698,364.17	61.20%
15	44170	000	00000	000	Miscellaneous Refunds	0.00	0.00	0.00	0.00	2,263.74	-2,263.74	100.0%
15	44990	000	00000	000	Other Local Revenues	500,000.00	0.00	500,000.00	0.00	500,000.00	0.00	100.0%
					151 44---	2,300,000.00	0.00	2,300,000.00	98.94	1,603,899.57	696,100.43	
15	48990	000	00000	000	Other	0.00	0.00	0.00	0.00	0.00	0.00	100.0%
					151 48---	0.00	0.00	0.00	0.00	0.00	0.00	
15	49800	000	00000	000	Transfers In	0.00	0.00	0.00	0.00	0.00	0.00	100.0%

REVENUE SUMMARY REPORT

April 2025-2026

HAMBLÉN COUNTY ACCOUNTS & BUDGETS

101 General Fund

Fund(s) Selected:
101; 122; 128; 151; 154;
171; 173; 176; 177; 178;

Fd	Acct	Obj	Loc	Prg Description	Budget Amount	Budget Amendments	Amended Budget	MTD Revenues	YTD Revenues	Uncollected Revenues	% of Bdgt
		151	49---		0.00	0.00	0.00	0.00	0.00	0.00	
General Debt Service Fund #(151) Totals:					9,954,124.00	0.00	9,954,124.00	98.94	8,881,526.51	1,072,597.49	

May 21, 2026

REVENUE SUMMARY REPORT

April 2025-2026

HAMBLLEN COUNTY ACCOUNTS & BUDGETS

101 General Fund

Fund(s) Selected:
101; 122; 128; 151; 154;
171; 173; 176; 177; 178;

Fd	Acct	Obj	Loc	Prg Description	Budget Amount	Budget Amendments	Amended Budget	MTD Revenues	YTD Revenues	Uncollected Revenues	% of Bdgt
15	44110	000	00000	000 Investment Income	200,000.00	0.00	200,000.00	0.00	108,920.86	91,079.14	54.46%
			154	44---	200,000.00	0.00	200,000.00	0.00	108,920.86	91,079.14	
15	48990	000	00000	000 Other	879,749.00	0.00	879,749.00	0.00	406,301.85	473,447.15	46.18%
			154	48---	879,749.00	0.00	879,749.00	0.00	406,301.85	473,447.15	
15	49100	000	00000	000 Bonds Issued	0.00	0.00	0.00	0.00	0.00	0.00	100.0%
15	49410	000	00000	000 Premiums On Debt Sold	0.00	0.00	0.00	0.00	0.00	0.00	100.0%
15	49800	000	00000	000 Transfers In	0.00	0.00	0.00	0.00	0.00	0.00	100.0%
			154	49---	0.00	0.00	0.00	0.00	0.00	0.00	
Special Debt Service Totals:					1,079,749.00	0.00	1,079,749.00	0.00	515,222.71	564,526.29	

May 21, 2026

REVENUE SUMMARY REPORT

April 2025-2026

HAMBLEN COUNTY ACCOUNTS & BUDGETS

101 General Fund

Fund(s) Selected:
101; 122; 128; 151; 154;
171; 173; 176; 177; 178;

Fd	Acct	Obj	Loc	Prg	Description	Budget Amount	Budget Amendments	Amended Budget	MTD Revenues	YTD Revenues	Uncollected Revenues	% of Bdgt
17	44110	000	00000	000	Investment Income	0.00	0.00	0.00	0.00	0.00	0.00	100.0%
17	44120	000	00000	000	Lease/Rentals	0.00	0.00	0.00	0.00	0.00	0.00	100.0%
17	44170	000	00000	000	Miscellaneous Refunds	0.00	0.00	0.00	0.00	0.00	0.00	100.0%
17	44530	000	00000	000	Sale Of Equipment	0.00	0.00	0.00	0.00	0.00	0.00	100.0%
					171 44---	0.00	0.00	0.00	0.00	0.00	0.00	
17	46190	000	00000	000	Other General Government Grants	0.00	0.00	0.00	0.00	0.00	0.00	100.0%
17	46980	000	00000	000	Other State Grants	0.00	0.00	0.00	0.00	0.00	0.00	100.0%
17	46980	000	07004	000	Other State Grants - CDBG Grant - Fire Engine	0.00	0.00	0.00	0.00	0.00	0.00	100.0%
					171 46---	0.00	0.00	0.00	0.00	0.00	0.00	
17	47180	000	00000	000	Community Development	0.00	0.00	0.00	0.00	0.00	0.00	100.0%
17	47590	000	00000	000	Other Federal Through State	0.00	0.00	0.00	0.00	338,080.33	-338,080.33	100.0%
17	47590	000	07004	000	Other Federal Through State - CDBG Grant - Fire Engine	0.00	0.00	0.00	0.00	0.00	0.00	100.0%
					171 47---	0.00	0.00	0.00	0.00	338,080.33	-338,080.33	
17	48610	000	00000	000	Donations	0.00	0.00	0.00	0.00	0.00	0.00	100.0%
					171 48---	0.00	0.00	0.00	0.00	0.00	0.00	
17	49100	000	00000	000	Bonds Issued	0.00	0.00	0.00	0.00	0.00	0.00	100.0%
17	49700	000	00000	000	Insurance Recovery	0.00	0.00	0.00	0.00	0.00	0.00	100.0%
17	49800	000	00000	000	Transfers In	0.00	0.00	0.00	0.00	0.00	0.00	100.0%
					171 49---	0.00	0.00	0.00	0.00	0.00	0.00	
General Capital Projects Fund #(171) Totals:						0.00	0.00	0.00	0.00	338,080.33	-338,080.33	

REVENUE SUMMARY REPORT

April 2025-2026

HAMBLEEN COUNTY ACCOUNTS & BUDGETS

101 General Fund

Fund(s) Selected:
101; 122; 128; 151; 154;
171; 173; 176; 177; 178;

Fd	Acct	Obj	Loc	Prg	Description	Budget Amount	Budget Amendments	Amended Budget	MTD Revenues	YTD Revenues	Uncollected Revenues	% of Bdgt
17	49800	000	000000	000	Transfers In	0.00	0.00	0.00	0.00	0.00	0.00	100.0%
17	49999	000	000000	000	Prior Year Revenue	0.00	0.00	0.00	0.00	0.00	0.00	100.0%
			173	49---		0.00	0.00	0.00	0.00	0.00	0.00	
					Sanitation Projects Fund #(173) Totals:	0.00	0.00	0.00	0.00	0.00	0.00	

May 21, 2026

REVENUE SUMMARY REPORT

April 2025-2026

HAMBLLEN COUNTY ACCOUNTS & BUDGETS

101 General Fund

Fund(s) Selected:
101; 122; 128; 151; 154;
171; 173; 176; 177; 178;

Fd	Acct	Obj	Loc	Prg	Description	Budget Amount	Budget Amendments	Amended Budget	MTD Revenues	YTD Revenues	Uncollected Revenues	% of Bdgt
17	40210	000	00000	000	Local Option Sales Tax	0.00	0.00	0.00	0.00	0.00	0.00	100.0%
17	40240	000	00000	000	Wheel Tax	3,030,000.00	0.00	3,030,000.00	0.00	2,172,126.79	857,873.21	71.68%
			176	40---		3,030,000.00	0.00	3,030,000.00	0.00	2,172,126.79	857,873.21	
17	44110	000	00000	000	Investment Income	365,000.00	0.00	365,000.00	0.00	365,000.00	0.00	100.0%
17	44170	000	00000	000	Miscellaneous Refunds	0.00	0.00	0.00	0.00	0.00	0.00	100.0%
			176	44--		365,000.00	0.00	365,000.00	0.00	365,000.00	0.00	
17	46420	000	00000	000	State Aid Program	0.00	770,839.34	770,839.34	0.00	0.00	770,839.34	0.000%
17	46851	000	00000	000	State Revenue Sharing - T.V.A.	0.00	0.00	0.00	0.00	0.00	0.00	100.0%
17	46980	000	00000	000	Other State Grants	0.00	0.00	0.00	0.00	0.00	0.00	100.0%
			176	46---		0.00	770,839.34	770,839.34	0.00	0.00	770,839.34	
17	47590	000	00000	000	Other Federal Through State	0.00	0.00	0.00	0.00	0.00	0.00	100.0%
			176	47--		0.00	0.00	0.00	0.00	0.00	0.00	
Highway Capital Projects Fund #(176) Totals:						3,395,000.00	770,839.34	4,165,839.34	0.00	2,537,126.79	1,628,712.55	

REVENUE SUMMARY REPORT

April 2025-2026

HAMBLEEN COUNTY ACCOUNTS & BUDGETS

101 General Fund

Fund(s) Selected:
101; 122; 128; 151; 154;
171; 173; 176; 177; 178;

Fd	Acct	Obj	Loc	Prg	Description	Budget Amount	Budget Amendments	Amended Budget	MTD Revenues	YTD Revenues	Uncollected Revenues	% of Bdgt
17	49100	000	000000	000	Bonds Issued	0.00	0.00	0.00	0.00	0.00	0.00	100.0%
17	49410	000	000000	000	Premiums On Debt Sold	0.00	0.00	0.00	0.00	0.00	0.00	100.0%
			177	49--		0.00	0.00	0.00	0.00	0.00	0.00	
Education Capital Projects Fund #(177) Totals:						0.00	0.00	0.00	0.00	0.00	0.00	

May 21, 2026

REVENUE SUMMARY REPORT

April 2025-2026

HAMBLEEN COUNTY ACCOUNTS & BUDGETS

101 General Fund

Fund(s) Selected:
101; 122; 128; 151; 154;
171; 173; 176; 177; 178;

Fd	Acct	Obj	Loc	Prg Description	Budget Amount	Budget Amendments	Amended Budget	MTD Revenues	YTD Revenues	Uncollected Revenues	% of Bdgt
17	44110	000	00000	000 Investment Income	0.00	0.00	0.00	0.00	66,155.70	-66,155.70	100.0%
			178	44---	<u>0.00</u>	<u>0.00</u>	<u>0.00</u>	<u>0.00</u>	<u>66,155.70</u>	<u>-66,155.70</u>	
17	47590	000	00000	000 Other Federal Through State	0.00	0.00	0.00	0.00	1,029,253.59	-1,029,253.59	100.0%
17	47990	000	00000	000 Other Direct Federal Revenue	0.00	0.00	0.00	0.00	0.00	0.00	100.0%
			178	47---	<u>0.00</u>	<u>0.00</u>	<u>0.00</u>	<u>0.00</u>	<u>1,029,253.59</u>	<u>-1,029,253.59</u>	
17	49800	000	00000	000 Transfers In	0.00	0.00	0.00	0.00	0.00	0.00	100.0%
			178	49---	<u>0.00</u>	<u>0.00</u>	<u>0.00</u>	<u>0.00</u>	<u>0.00</u>	<u>0.00</u>	
Other Capital Projects Fund/Fu Totals:					<u><u>0.00</u></u>	<u><u>0.00</u></u>	<u><u>0.00</u></u>	<u><u>0.00</u></u>	<u><u>1,095,409.29</u></u>	<u><u>-1,095,409.29</u></u>	

May 21, 2026

REVENUE SUMMARY REPORT

April 2025-2026

HAMBLLEN COUNTY ACCOUNTS & BUDGETS

101 General Fund

Fund(s) Selected:
101; 122; 128; 151; 154;
171; 173; 176; 177; 178;

Fd	Acct	Obj	Loc	Prg	Description	Budget Amount	Budget Amendments	Amended Budget	MTD Revenues	YTD Revenues	Uncollected Revenues	% of Bdgt
18	44110	000	00000	000	Investment Income	0.00	0.00	0.00	0.00	340,907.36	-340,907.36	100.0%
18	44120	000	00000	000	Lease/Rentals	0.00	0.00	0.00	0.00	0.00	0.00	100.0%
18	44170	000	00000	000	Miscellaneous Refunds	0.00	0.00	0.00	0.00	0.00	0.00	100.0%
189 44--						0.00	0.00	0.00	0.00	340,907.36	-340,907.36	
18	49100	000	00000	000	Bonds Issued	0.00	0.00	0.00	0.00	9,818,146.19	-9,818,146.19	100.0%
18	49410	000	00000	000	Premiums On Debt Sold	0.00	0.00	0.00	0.00	0.00	0.00	100.0%
18	49500	000	00000	000	Other Loans Issued	0.00	0.00	0.00	0.00	0.00	0.00	100.0%
18	49800	000	00000	000	Transfers In	0.00	0.00	0.00	0.00	0.00	0.00	100.0%
189 49--						0.00	0.00	0.00	0.00	9,818,146.19	-9,818,146.19	
Other Capital Projects Fund # (189) Totals:						0.00	0.00	0.00	0.00	10,159,053.	-10,159,053.	

May 21, 2026

REVENUE SUMMARY REPORT

April 2025-2026

HAMBLLEN COUNTY ACCOUNTS & BUDGETS

101 General Fund

Fund(s) Selected:
101; 122; 128; 151; 154;
171; 173; 176; 177; 178;

Fd	Acct	Obj	Loc	Prg	Description	Budget Amount	Budget Amendments	Amended Budget	MTD Revenues	YTD Revenues	Uncollected Revenues	% of Bdg
26	43101	000	00000	000	Self-Insurance Premiums/Contributions	0.00	0.00	0.00	0.00	0.00	0.00	100.0%
26	43101	000	01002	000	Self-Insurance Premiums/Contributions - Highway	0.00	0.00	0.00	0.00	233,580.56	-233,580.56	100.0%
26	43101	000	01003	000	Self-Insurance Premiums/Contributions - Garbage	0.00	0.00	0.00	0.00	209,942.96	-209,942.96	100.0%
26	43101	000	01001	000	Self-Insurance Premiums/Contributions - Courthouse	0.00	0.00	0.00	0.00	2,647,879.92	-2,647,879.92	100.0%
26	43101	000	01004	000	Self-Insurance Premiums/Contributions - Library	0.00	0.00	0.00	0.00	0.00	0.00	100.0%
26	43101	000	01009	000	Self-Insurance Premiums/Contributions - E911	0.00	0.00	0.00	0.00	0.00	0.00	100.0%
26	43101	000	01010	000	Self-Insurance Premiums/Contributions - Landfill	0.00	0.00	0.00	0.00	104,717.97	-104,717.97	100.0%
26	43102	000	01001	001	Other Employee Benefit Charges/Contributions -	0.00	0.00	0.00	0.00	88,078.30	-88,078.30	100.0%
26	43102	000	01001	002	Other Employee Benefit Charges/Contributions -	0.00	0.00	0.00	0.00	20,128.71	-20,128.71	100.0%
26	43102	000	01002	001	Other Employee Benefit Charges/Contributions - Highway	0.00	0.00	0.00	0.00	8,310.16	-8,310.16	100.0%
26	43102	000	01002	002	Other Employee Benefit Charges/Contributions - Highway	0.00	0.00	0.00	0.00	1,698.26	-1,698.26	100.0%
26	43102	000	01003	001	Other Employee Benefit Charges/Contributions - Garbage	0.00	0.00	0.00	0.00	7,633.90	-7,633.90	100.0%
26	43102	000	01003	002	Other Employee Benefit Charges/Contributions - Garbage	0.00	0.00	0.00	0.00	1,431.80	-1,431.80	100.0%
26	43102	000	01004	001	Other Employee Benefit Charges/Contributions - Library	0.00	0.00	0.00	0.00	0.00	0.00	100.0%
26	43102	000	01004	002	Other Employee Benefit Charges/Contributions - Library	0.00	0.00	0.00	0.00	0.00	0.00	100.0%
26	43120	000	00000	000	Patient Charges	0.00	0.00	0.00	0.00	0.00	0.00	100.0%
26	43120	000	01007	000	Patient Charges - Retirees	0.00	0.00	0.00	0.00	0.00	0.00	100.0%
26	43120	000	01099	000	Patient Charges - Cobra	0.00	0.00	0.00	0.00	0.00	0.00	100.0%
26	43120	000	01001	000	Patient Charges - Courthouse	0.00	0.00	0.00	5,993.28	5,993.28	-5,993.28	100.0%
26	43120	000	01002	000	Patient Charges - Highway	0.00	0.00	0.00	0.00	0.00	0.00	100.0%
26	43120	000	01009	000	Patient Charges - E911	0.00	0.00	0.00	0.00	0.00	0.00	100.0%
26	43120	000	01003	000	Patient Charges - Garbage	0.00	0.00	0.00	0.00	0.00	0.00	100.0%
26	43190	000	01004	000	Other General Service Charges - Library	0.00	0.00	0.00	0.00	3,433.49	-3,433.49	100.0%
26	43190	000	01009	000	Other General Service Charges - E911	0.00	0.00	0.00	0.00	0.00	0.00	100.0%
26	43190	000	01011	000	Other General Service Charges - City Of Morristown	0.00	0.00	0.00	0.00	9,082.29	-9,082.29	100.0%
26	43190	000	01001	000	Other General Service Charges - Courthouse	0.00	0.00	0.00	0.00	0.00	0.00	100.0%
26	43190	000	01010	000	Other General Service Charges - Landfill	0.00	0.00	0.00	0.00	5,500.26	-5,500.26	100.0%
26	43190	000	01002	000	Other General Service Charges - Highway	0.00	0.00	0.00	0.00	0.00	0.00	100.0%

REVENUE SUMMARY REPORT

April 2025-2026

HAMBLLEN COUNTY ACCOUNTS & BUDGETS

101 General Fund

Fund(s) Selected:
101; 122; 128; 151; 154;
171; 173; 176; 177; 178;

Fd	Acct	Obj	Loc	Prg	Description	Budget Amount	Budget Amendments	Amended Budget	MTD Revenues	YTD Revenues	Uncollected Revenues	% of Bdg
26	43190	000	01003	000	Other General Service Charges - Garbage	0.00	0.00	0.00	0.00	0.00	0.00	100.0%
26	43194	000	01001	000	Service Charges (No Show Fee) - Courthouse	0.00	0.00	0.00	0.00	200.00	-200.00	100.0%
26	43194	000	01010	000	Service Charges (No Show Fee) - Landfill	0.00	0.00	0.00	0.00	0.00	0.00	100.0%
26	43194	000	01002	000	Service Charges (No Show Fee) - Highway	0.00	0.00	0.00	0.00	0.00	0.00	100.0%
26	43194	000	01003	000	Service Charges (No Show Fee) - Garbage	0.00	0.00	0.00	0.00	0.00	0.00	100.0%
26	43194	000	01009	000	Service Charges (No Show Fee) - E911	0.00	0.00	0.00	0.00	0.00	0.00	100.0%
26	43990	000	01001	000	Other Charges For Services - Courthouse	0.00	0.00	0.00	0.00	0.00	0.00	100.0%
26	43990	000	01004	000	Other Charges For Services - Library	0.00	0.00	0.00	0.00	0.00	0.00	100.0%
26	43990	000	01009	000	Other Charges For Services - E911	0.00	0.00	0.00	0.00	0.00	0.00	100.0%
26	43990	000	01010	000	Other Charges For Services - Landfill	0.00	0.00	0.00	0.00	0.00	0.00	100.0%
26	43990	000	01003	000	Other Charges For Services - Garbage	0.00	0.00	0.00	0.00	0.00	0.00	100.0%
26	43990	000	01002	000	Other Charges For Services - Highway	0.00	0.00	0.00	0.00	0.00	0.00	100.0%
264 43---						0.00	0.00	0.00	5,993.28	3,347,611.86	-3,347,611.86	
26	44110	000	00000	000	Investment Income	0.00	0.00	0.00	0.00	0.00	0.00	100.0%
26	44160	000	01007	000	Retirees' Insurance Payments - Retirees	0.00	0.00	0.00	0.00	20,250.00	-20,250.00	100.0%
26	44160	000	01007	001	Retirees' Insurance Payments - Retirees	0.00	0.00	0.00	0.00	649.08	-649.08	100.0%
26	44160	000	01007	002	Retirees' Insurance Payments - Retirees	0.00	0.00	0.00	0.00	121.60	-121.60	100.0%
26	44161	000	00000	000	Cobra Insurance Payments	0.00	0.00	0.00	0.00	0.00	0.00	100.0%
26	44170	000	01001	000	Miscellaneous Refunds - Courthouse	0.00	0.00	0.00	140,726.23	201,090.44	-201,090.44	100.0%
26	44170	000	01003	000	Miscellaneous Refunds - Garbage	0.00	0.00	0.00	0.00	0.00	0.00	100.0%
26	44170	000	01004	000	Miscellaneous Refunds - Library	0.00	0.00	0.00	0.00	0.00	0.00	100.0%
26	44170	000	01009	000	Miscellaneous Refunds - E911	0.00	0.00	0.00	0.00	0.00	0.00	100.0%
26	44170	000	01010	000	Miscellaneous Refunds - Landfill	0.00	0.00	0.00	0.00	0.00	0.00	100.0%
264 44---						0.00	0.00	0.00	140,726.23	222,111.12	-222,111.12	
26	48140	000	01010	000	Contracted Services - Landfill	0.00	0.00	0.00	0.00	0.00	0.00	100.0%

REVENUE SUMMARY REPORT

April 2025-2026

HAMBLLEN COUNTY ACCOUNTS & BUDGETS

101 General Fund

Fund(s) Selected:
101; 122; 128; 151; 154;
171; 173; 176; 177; 178;

Fd	Acct	Obj	Loc	Prg Description	Budget Amount	Budget Amendments	Amended Budget	MTD Revenues	YTD Revenues	Uncollected Revenues	% of Bdgt
				264 48---	0.00	0.00	0.00	0.00	0.00	0.00	
26	49800	000	00000	000 Transfers In	0.00	0.00	0.00	0.00	0.00	0.00	100.0%
				264 49---	0.00	0.00	0.00	0.00	0.00	0.00	
Employee Insurance - General Fund#(264) Totals:					0.00	0.00	0.00	146,719.51	3,569,722.98	-3,569,722.98	

May 21, 2026

REVENUE SUMMARY REPORT

April 2025-2026

HAMBLLEN COUNTY ACCOUNTS & BUDGETS

101 General Fund

Fund(s) Selected:
101; 122; 128; 151; 154;
171; 173; 176; 177; 178;

Fd	Acct	Obj	Loc	Prg	Description	Budget Amount	Budget Amendments	Amended Budget	MTD Revenues	YTD Revenues	Uncollected Revenues	% of Bdgt
33	43102	000	00000	000	Other Employee Benefit Charges/Contributions	0.00	0.00	0.00	0.00	26,631.87	-26,631.87	100.0%
				334 43---		0.00	0.00	0.00	0.00	26,631.87	-26,631.87	
33	44110	000	00000	000	Investment Income	0.00	0.00	0.00	0.00	0.00	0.00	100.0%
33	44170	000	00000	000	Miscellaneous Refunds	0.00	0.00	0.00	0.00	125.26	-125.26	100.0%
				334 44---		0.00	0.00	0.00	0.00	125.26	-125.26	
Employee Benefit Trust Fund #(334) Totals:						0.00	0.00	0.00	0.00	26,757.13	-26,757.13	

May 21, 2026

REVENUE SUMMARY REPORT

April 2025-2026

HAMBLEEN COUNTY ACCOUNTS & BUDGETS

101 General Fund

Fund(s) Selected:
101; 122; 128; 151; 154;
171; 173; 176; 177; 178;

Fd	Acct	Obj	Loc	Prg	Description	Budget Amount	Budget Amendments	Amended Budget	MTD Revenues	YTD Revenues	Uncollected Revenues	% of Bdgt
35	40210	000	00000	000	Local Option Sales Tax	0.00	0.00	0.00	0.00	15,453,299.41	-15,453,299.41	100.0%
			351	40---		0.00	0.00	0.00	0.00	15,453,299.	-15,453,299.	
			Cities - Sales Tax Fund #(351) Totals:			0.00	0.00	0.00	0.00	15,453,299.	-15,453,299.	

May 21, 2026

REVENUE SUMMARY REPORT

April 2025-2026

HAMBLEN COUNTY ACCOUNTS & BUDGETS

Fund(s) Selected:

116

116 Sanitation

Fd	Acct	Obj	Loc	Prg	Description	Budget Amount	Budget Amendments	Amended Budget	MTD Revenues	YTD Revenues	Uncollected Revenues	% of Bdg
11	40110	000	00000	000	Current Property Tax	1,500,000.00	0.00	1,500,000.00	0.00	1,782,147.94	-282,147.94	118.8%
11	40120	000	00000	000	Trustee's Collections - Prior Year	20,000.00	0.00	20,000.00	0.00	30,858.03	-10,858.03	154.2%
11	40125	000	00000	000	Trustee's Collections - Bankruptcy	700.00	0.00	700.00	0.00	466.14	233.86	66.59%
11	40130	000	00000	000	Circuit Clerk/Clerk & Master Collections-Prior Yrs	3,000.00	0.00	3,000.00	0.00	5,123.97	-2,123.97	170.7%
11	40140	000	00000	000	Interest And Penalty	12,000.00	0.00	12,000.00	0.00	6,492.93	5,507.07	54.10%
11	40161	000	00000	000	Payments In-Lieu-Of Taxes - T.V.A.	0.00	0.00	0.00	0.00	0.00	0.00	100.0%
11	40163	000	00000	000	Payments In-Lieu of Taxes - Other	0.00	0.00	0.00	0.00	0.00	0.00	100.0%
11	40210	000	00000	000	Local Option Sales Tax	1,950,000.00	0.00	1,950,000.00	0.00	1,465,213.89	484,786.11	75.13%
11	40330	000	00000	000	Wholesale Beer Tax	118,600.00	0.00	118,600.00	0.00	75,397.27	43,202.73	63.57%
					116 40---	3,604,300.00	0.00	3,604,300.00	0.00	3,365,700.17	238,599.83	
1	41510	000	00000	000	Beer Permits	1,880.00	0.00	1,880.00	0.00	1,900.00	-20.00	101.0%
					116 41---	1,880.00	0.00	1,880.00	0.00	1,900.00	-20.00	
11	44110	000	00000	000	Investment Income	500,000.00	0.00	500,000.00	0.00	500,000.00	0.00	100.0%
11	44130	000	00000	000	Sale Of Materials And Supplies	10,000.00	0.00	10,000.00	0.00	17,500.00	-7,500.00	175.0%
11	44170	000	00000	000	Miscellaneous Refunds	0.00	0.00	0.00	0.00	0.00	0.00	100.0%
11	44180	000	00000	000	Expenditure Credits	0.00	0.00	0.00	0.00	0.00	0.00	100.0%
11	44530	000	00000	000	Sale Of Equipment	0.00	0.00	0.00	0.00	27,454.00	-27,454.00	100.0%
					116 44---	510,000.00	0.00	510,000.00	0.00	544,954.00	-34,954.00	
11	46190	000	00000	000	Other General Government Grants	0.00	0.00	0.00	0.00	1,000,000.00	-1,000,000.00	100.0%
11	46830	000	00000	000	Beer Tax	18,000.00	0.00	18,000.00	0.00	9,212.27	8,787.73	51.17%
					116 46---	18,000.00	0.00	18,000.00	0.00	1,009,212.27	-991,212.27	
11	47303	000	00000	000	COVID-19 Grant	0.00	0.00	0.00	0.00	0.00	0.00	100.0%

REVENUE SUMMARY REPORT

April 2025-2026

HAMBLEEN COUNTY ACCOUNTS & BUDGETS

Fund(s) Selected:
116

116 Sanitation

Fd	Acct	Obj	Loc	Prg Description	Budget Amount	Budget Amendments	Amended Budget	MTD Revenues	YTD Revenues	Uncollected Revenues	% of Bdgt
				116 47---	0.00	0.00	0.00	0.00	0.00	0.00	
11	49700	000	00000	000 Insurance Recovery	0.00	50,002.20	50,002.20	0.00	0.00	50,002.20	0.000%
11	49800	000	00000	000 Operating Transfers In	0.00	0.00	0.00	0.00	0.00	0.00	100.0%
				116 49--	0.00	50,002.20	50,002.20	0.00	0.00	50,002.20	
Solid Waste/Sanitation Fund #(116) Totals:					4,134,180.00	50,002.20	4,184,182.20	0.00	4,921,766.44	-737,584.24	

May 21, 2026

REVENUE SUMMARY REPORT

April 2025-2026

HAMBLEEN COUNTY ACCOUNTS & BUDGETS

Fund(s) Selected:
131

131 Highway

Fd	Acct	Obj	Loc	Prg	Description	Budget Amount	Budget Amendments	Amended Budget	MTD Revenues	YTD Revenues	Uncollected Revenues	% of Bdgt
13	40210	000	00000	000	Local Option Sales Tax	200,000.00	0.00	200,000.00	0.00	200,000.00	0.00	100.0%
13	40280	000	00000	000	Mineral Severance Tax	70,000.00	0.00	70,000.00	0.00	41,562.56	28,437.44	59.37%
131 40---						270,000.00	0.00	270,000.00	0.00	241,562.56	28,437.44	
13	44110	000	00000	000	Investment Income	75,000.00	0.00	75,000.00	0.00	75,000.00	0.00	100.0%
13	44130	000	00000	000	Sale Of Materials And Supplies	0.00	0.00	0.00	0.00	0.00	0.00	100.0%
13	44170	000	00000	000	Miscellaneous Refunds	0.00	0.00	0.00	0.00	3,920.74	-3,920.74	100.0%
13	44180	000	00000	000	Expenditure Credits	0.00	0.00	0.00	0.00	281.60	-281.60	100.0%
13	44530	000	00000	000	Sale Of Equipment	0.00	0.00	0.00	0.00	42,383.00	-42,383.00	100.0%
13	44560	000	00000	000	Damages Recovered From Individuals	0.00	0.00	0.00	0.00	0.00	0.00	100.0%
131 44---						75,000.00	0.00	75,000.00	0.00	121,585.34	-46,585.34	
May 2025	46420	000	00000	000	State Aid Program	0.00	0.00	0.00	0.00	0.00	0.00	100.0%
46851	000	00000	000	000	State Revenue Sharing - T.V.A.	200,000.00	0.00	200,000.00	0.00	200,000.00	0.00	100.0%
13	46920	000	00000	000	Gasoline and Motor Fuel Tax	2,375,000.00	0.00	2,375,000.00	0.00	1,613,288.51	761,711.49	67.92%
13	46925	000	00000	000	Hybrid/Electric Vehicle Registration Fee	20,000.00	0.00	20,000.00	0.00	24,306.95	-4,306.95	121.5%
13	46930	000	00000	000	Petroleum Special Tax	42,736.00	0.00	42,736.00	0.00	28,490.60	14,245.40	66.66%
13	46980	000	00000	000	Other State Grants	0.00	0.00	0.00	0.00	0.00	0.00	100.0%
131 46---						2,637,736.00	0.00	2,637,736.00	0.00	1,866,086.06	771,649.94	
13	47100	000	00000	000	Federal Through State	0.00	0.00	0.00	0.00	0.00	0.00	100.0%
13	47230	000	00000	000	Disaster Relief	0.00	0.00	0.00	0.00	0.00	0.00	100.0%
13	47303	000	00000	000	COVID-19 Grant	0.00	0.00	0.00	0.00	0.00	0.00	100.0%
131 47---						0.00	0.00	0.00	0.00	0.00	0.00	
13	48120	000	00000	000	Paving and Maintenance	0.00	0.00	0.00	0.00	0.00	0.00	100.0%
13	48610	000	00000	000	Donations	0.00	0.00	0.00	0.00	0.00	0.00	100.0%

REVENUE SUMMARY REPORT

April 2025-2026

HAMBLLEN COUNTY ACCOUNTS & BUDGETS

Fund(s) Selected:
131

131 Highway

Fd	Acct	Obj	Loc	Prg Description	Budget Amount	Budget Amendments	Amended Budget	MTD Revenues	YTD Revenues	Uncollected Revenues	% of Bdgt
			131	48---	0.00	0.00	0.00	0.00	0.00	0.00	
13	49700	000	00000	000 Insurance Recovery	0.00	0.00	0.00	0.00	0.00	0.00	100.0%
13	49800	000	00000	000 Transfers In	0.00	0.00	0.00	0.00	0.00	0.00	100.0%
			131	49---	0.00	0.00	0.00	0.00	0.00	0.00	
Highway/Public Works Fund (#131) Totals:					2,982,736.00	0.00	2,982,736.00	0.00	2,229,233.96	753,502.04	

May 21, 2026

MONTHLY CHECKS

May 21, 2026

[Return to Regular Calendar](#)

COMMISSION APPROVAL LISTING

ACCT	OB	Name	Date	Check Nbr	Description	Amount Paid
Fund: General Fund #(101)						
51100	317	Data Processing Services	04/23/2026	1010284876	GovConnection, Inc.	11.52
51100	317	Data Processing Services	04/30/2026	1010284922	GovConnection, Inc.	11.52
51100	599	Other Charges	04/16/2026	1010284841	Citizen Tribune	43.05
51100	599	Other Charges	04/30/2026	1010284916	Evans Office Supply Co	15.00
51100		County Commission		Check Count: 4	Total:	81.09
51300	307	Communication	04/23/2026	1010284866	AT&T Mobility	43.50
51300	317	Data Processing Services	04/23/2026	1010284876	GovConnection, Inc.	23.04
51300	317	Data Processing Services	04/30/2026	1010284922	GovConnection, Inc.	23.04
51300	351	Rentals	04/16/2026	1010284838	Canon Solutions America, Inc	182.34
51300	355	Travel	04/16/2026	1010284848	HomeTrust Bank	516.46
51300	435	Office Supplies	04/16/2026	1010284853	Mildred's Florist & Gifts, Inc.	988.00
51300	599	Other Charges	04/02/2026	1010284771	TN County Services Association	250.00
51300	599	Other Charges	04/09/2026	1010284817	South Marketing Group	650.00
51300	599	Other Charges	04/16/2026	1010284848	HomeTrust Bank	88.80
51300		County Mayor/Executive		Check Count: 8	Total:	2,765.18
51400	331	Legal Services	04/09/2026	1010284824	Taylor Law Firm	180.00
51400	331	Legal Services	04/23/2026	1010284871	Capps & Byrd LLP	3,421.25
51400	331	Legal Services	04/30/2026	1010284904	Anderson & Van Tol PLLC	3,990.00
51400		County Attorney		Check Count: 3	Total:	7,591.25
51500	307	Communication	04/23/2026	1010284866	AT&T Mobility	43.50
51500	317	Data Processing Services	04/23/2026	1010284876	GovConnection, Inc.	34.56
51500	317	Data Processing Services	04/30/2026	1010284922	GovConnection, Inc.	34.56
51500	334	Maintenance Agreements	04/09/2026	1010284794	EasyVote Solutions LLC	2,500.00
51500	349	Printing, Stationery And Forms	04/09/2026	1010284808	Morristown Signs, Inc	320.00
51500	351	Rentals	04/09/2026	1010284798	Margaret Gardner	500.00

COMMISSION APPROVAL LISTING

ACCT	OB	Name	Date	Check Nbr	Description	Amount Paid
Fund: General Fund #(101)						
51500	351	Rentals	04/16/2026	1010284838	Canon Solutions America, Inc	81.56
51500	351	Rentals	04/23/2026	1010284890	MUS Fibernet	59.95
51500	435	Office Supplies	04/23/2026	1010284886	Microvote Corporation	445.56
51500	719	Office Equipment	04/27/2026	1010284900	Amazon Capital Services, Inc.	313.97
51500		Election Commission		Check Count: 10	Total:	4,333.66
51600	317	Data Processing Services	04/16/2026	1010284849	i3 Verticals LLC	3,613.89
51600	317	Data Processing Services	04/23/2026	1010284876	GovConnection, Inc.	80.64
51600	317	Data Processing Services	04/30/2026	1010284922	GovConnection, Inc.	80.64
51600	709	Data Processing Equipment	04/02/2026	1010284756	i3 Verticals LLC	8.44
51600	709	Data Processing Equipment	04/09/2026	1010284801	i3 Verticals LLC	1,356.25
51600	709	Data Processing Equipment	04/16/2026	1010284838	Canon Solutions America, Inc	59.65
51600	709	Data Processing Equipment	04/16/2026	1010284849	i3 Verticals LLC	1,511.71
51600		Register Of Deeds		Check Count: 6	Total:	6,711.22
51720	307	Communication	04/02/2026	1010284776	Verizon Wireless	68.00
51720	307	Communication	04/23/2026	1010284866	AT&T Mobility	130.50
51720	312	Contracts With Private Agencies	04/23/2026	1010284887	Robert Montgomery	240.00
51720	317	Data Processing Services	04/23/2026	1010284876	GovConnection, Inc.	79.75
51720	317	Data Processing Services	04/30/2026	1010284922	GovConnection, Inc.	79.75
51720	320	Dues And Memberships	04/16/2026	9101001397	Darrell Lynn Chase	300.00
51720	332	Legal Notices, Recording And Court Costs	04/23/2026	1010284874	Citizen Tribune	216.48
51720	338	Maintenance And Repair Services - Vehicles	04/09/2026	1010284819	Spotless Brands Intermediate I, LLC	15.00
51720	338	Maintenance And Repair Services - Vehicles	04/30/2026	1010284939	Porter's Tire Store Inc.	69.74
51720	351	Rentals	04/16/2026	1010284838	Canon Solutions America, Inc	59.72
51720	425	Gasoline	04/30/2026	1010284918	Fuelman	83.62
51720	435	Office Supplies	04/30/2026	1010284916	Evans Office Supply Co	12.00

COMMISSION APPROVAL LISTING

ACCT	OB	Name	Date	Check Nbr	Description	Amount Paid
Fund: General Fund #(101)						
51720		Planning			Check Count: 12	Total: 1,354.56
51810	307	Communication	04/09/2026	1010284782	AT&T	658.04
51810	307	Communication	04/23/2026	1010284866	AT&T Mobility	270.09
51810	307	Communication	04/30/2026	1010284932	MetTel	1,017.69
51810	317	Data Processing Services	04/23/2026	1010284876	GovConnection, Inc.	11.52
51810	317	Data Processing Services	04/30/2026	1010284922	GovConnection, Inc.	11.52
51810	334	Maintenance Agreements	04/02/2026	1010284772	TN Dept Of Labor Workforce Development	82.50
51810	334	Maintenance Agreements	04/09/2026	1010284830	United Elevator Services LLC	2,247.56
51810	334	Maintenance Agreements	04/16/2026	1010284857	Murrell Burglar Alarm Co Inc	136.00
51810	334	Maintenance Agreements	04/30/2026	1010284944	TN Dept Of Labor Workforce Development	240.00
51810	335	Maintenance And Repair Service - Buildings	04/02/2026	1010284742	Ricky S Coffey	200.00
51810	335	Maintenance And Repair Service - Buildings	04/02/2026	1010284757	Lowe's	686.54
51810	335	Maintenance And Repair Service - Buildings	04/09/2026	1010284785	Carrot Top Industries	284.43
51810	335	Maintenance And Repair Service - Buildings	04/09/2026	1010284796	Fenco Supply Co	185.53
51810	335	Maintenance And Repair Service - Buildings	04/09/2026	1010284814	NAPA Auto Parts Of Morristown	8.12
51810	335	Maintenance And Repair Service - Buildings	04/09/2026	1010284822	T.E.G. Enterprises, Inc	285.00
51810	335	Maintenance And Repair Service - Buildings	04/16/2026	1010284859	Dylan Samples	256.00
51810	335	Maintenance And Repair Service - Buildings	04/27/2026	1010284900	Amazon Capital Services, Inc.	372.40
51810	335	Maintenance And Repair Service - Buildings	04/30/2026	1010284911	Ricky S Coffey	600.00
51810	335	Maintenance And Repair Service - Buildings	04/30/2026	1010284950	Wholesale Supply Group	41.84
51810	338	Maintenance And Repair Services - Vehicles	04/09/2026	1010284819	Spotless Brands Intermediate I, LLC	45.00
51810	410	Custodial Supplies	04/09/2026	1010284829	Unifirst Corp	302.56
51810	410	Custodial Supplies	04/09/2026	1010284832	Wet Washing Equipment Technologies	8,291.92
51810	415	Electricity	04/09/2026	1010284809	Morristown Utilities	3,283.00
51810	415	Electricity	04/16/2026	1010284855	Morristown Utilities	14,456.00
51810	415	Electricity	04/23/2026	1010284888	Morristown Utilities	22,725.00

COMMISSION APPROVAL LISTING

ACCT	OB	Name	Date	Check Nbr	Description	Amount Paid
Fund: General Fund #(101)						
51810	415	Electricity	04/30/2026	1010284936	Morristown Utilities	1,576.00
51810	425	Gasoline	04/30/2026	1010284918	Fuelman	362.68
51810	434	Natural Gas	04/02/2026	1010284737	Atmos Energy	571.36
51810	434	Natural Gas	04/23/2026	1010284867	Atmos Energy	12,349.71
51810	451	Uniforms	04/09/2026	1010284829	Unifirst Corp	281.64
51810	717	Maintenance Equipment	04/09/2026	1010284805	Lane Sales Power Equipment	1,611.97
51810		Other Facilities		Check Count: 30	Total:	73,451.62
51910	307	Communication	04/23/2026	1010284866	AT&T Mobility	40.96
51910	317	Data Processing Services	04/23/2026	1010284876	GovConnection, Inc.	23.04
51910	317	Data Processing Services	04/30/2026	1010284922	GovConnection, Inc.	23.04
51910	351	Rentals	04/16/2026	1010284838	Canon Solutions America, Inc	91.01
51910	435	Office Supplies	04/30/2026	1010284920	Gaylord Bros	170.18
51910		Preservation Of Records		Check Count: 5	Total:	348.23
52100	312	Contracts With Private Agencies	04/16/2026	1010284848	HomeTrust Bank	289.86
52100	312	Contracts With Private Agencies	04/09/2026	9101001394	William H Brittain	1,470.00
52100	317	Data Processing Services	04/23/2026	1010284876	GovConnection, Inc.	92.16
52100	317	Data Processing Services	04/30/2026	1010284922	GovConnection, Inc.	92.16
52100	320	Dues And Memberships	04/09/2026	1010284804	Lakeway Human Resource Management Association	100.00
52100	320	Dues And Memberships	04/09/2026	1010284811	Morristown-Hamblen Library	96,500.00
52100	334	Maintenance Agreements	04/30/2026	1010284907	CDW Government, Inc	208.68
52100	355	Travel	04/09/2026	9101001395	Wendy Williams	160.87
52100	435	Office Supplies	04/27/2026	1010284900	Amazon Capital Services, Inc.	224.72
52100	435	Office Supplies	04/30/2026	1010284916	Evans Office Supply Co	202.50
52100		Accounting And Budgeting		Check Count: 10	Total:	99,340.95
52300	307	Communication	04/23/2026	1010284866	AT&T Mobility	67.48

COMMISSION APPROVAL LISTING

ACCT	OB	Name	Date	Check Nbr	Description	Amount Paid
Fund: General Fund #(101)						
52300	317	Data Processing Services	04/23/2026	1010284876	GovConnection, Inc.	80.64
52300	317	Data Processing Services	04/30/2026	1010284922	GovConnection, Inc.	80.64
52300	338	Maintenance And Repair Services - Vehicles	04/09/2026	1010284819	Spotless Brands Intermediate I, LLC	30.00
52300	425	Gasoline	04/30/2026	1010284918	Fuelman	272.96
52300		Property Assessor's Office			Check Count: 5	Total: 531.72
52310	312	Contracts With Private Agencies	04/09/2026	1010284823	Tax Management Associates, Inc	6,750.00
52310	351	Rentals	04/16/2026	1010284838	Canon Solutions America, Inc	117.92
52310	435	Office Supplies	04/02/2026	1010284757	Lowe's	854.05
52310		Reappraisal Program			Check Count: 3	Total: 7,721.97
52400	317	Data Processing Services	04/23/2026	1010284876	GovConnection, Inc.	69.12
52400	317	Data Processing Services	04/30/2026	1010284922	GovConnection, Inc.	69.12
52400	332	Legal Notices, Recording And Court Costs	04/16/2026	1010284841	Citizen Tribune	486.40
52400	351	Rentals	04/16/2026	1010284838	Canon Solutions America, Inc	61.63
52400	355	Travel	04/16/2026	1010284848	HomeTrust Bank	-124.92
52400	719	Office Equipment	04/30/2026	1010284916	Evans Office Supply Co	1,275.73
52400		County Trustee's Office			Check Count: 6	Total: 1,837.08
52500	307	Communication	04/09/2026	1010284782	AT&T	47.57
52500	307	Communication	04/23/2026	1010284866	AT&T Mobility	40.96
52500	317	Data Processing Services	04/23/2026	1010284876	GovConnection, Inc.	237.94
52500	317	Data Processing Services	04/30/2026	1010284922	GovConnection, Inc.	237.94
52500	348	Postal Charges	04/02/2026	1010284750	Federal Express	51.71
52500	348	Postal Charges	04/09/2026	1010284795	Federal Express	5.12
52500	349	Printing, Stationery And Forms	04/30/2026	1010284916	Evans Office Supply Co	1,412.00
52500	349	Printing, Stationery And Forms	04/30/2026	1010284946	Tricor - State of TN	100.00
52500	351	Rentals	04/09/2026	1010284822	T.E.G. Enterprises, Inc	95.00

COMMISSION APPROVAL LISTING

ACCT	OB	Name	Date	Check Nbr	Description	Amount Paid
Fund: General Fund #(101)						
52500	351	Rentals	04/16/2026	1010284838	Canon Solutions America, Inc	110.08
52500	435	Office Supplies	04/30/2026	1010284916	Evans Office Supply Co	1,055.01
52500	435	Office Supplies	04/30/2026	1010284923	Government Forms and Supplies LLC	269.00
52500		County Clerk's Office		Check Count: 11	Total:	3,662.33
52600	307	Communication	04/23/2026	1010284866	AT&T Mobility	86.99
52600	312	Contracts With Private Agencies	04/09/2026	1010284792	CyberFOX, LLC	308.70
52600	312	Contracts With Private Agencies	04/09/2026	1010284793	DWM Consulting LLC	812.50
52600	312	Contracts With Private Agencies	04/09/2026	1010284813	MUS Fibernet	570.10
52600	317	Data Processing Services	04/02/2026	1010284774	Robert Tucker	199.98
52600	317	Data Processing Services	04/16/2026	1010284848	HomeTrust Bank	7.00
52600	317	Data Processing Services	04/23/2026	1010284876	GovConnection, Inc.	85.07
52600	317	Data Processing Services	04/30/2026	1010284922	GovConnection, Inc.	85.07
52600	355	Travel	04/23/2026	9101001399	Jeffrey Atkins	25.65
52600	355	Travel	04/23/2026	9101001402	Cameron A Solomon	8.99
52600	709	Data Processing Equipment	04/09/2026	1010284780	A-1 Equipment Rental	300.00
52600	709	Data Processing Equipment	04/16/2026	1010284848	HomeTrust Bank	261.00
52600	709	Data Processing Equipment	04/27/2026	1010284900	Amazon Capital Services, Inc.	701.42
52600	709	Data Processing Equipment	04/30/2026	1010284907	CDW Government, Inc	2,348.44
52600	709	Data Processing Equipment	04/30/2026	1010284926	Home Depot Credit Services	262.61
52600		Data Processing		Check Count: 14	Total:	6,063.52
53100	307	Communication	04/09/2026	1010284782	AT&T	39.30
53100	307	Communication	04/23/2026	1010284866	AT&T Mobility	84.46
53100	317	Data Processing Services	04/23/2026	1010284876	GovConnection, Inc.	295.83
53100	317	Data Processing Services	04/30/2026	1010284922	GovConnection, Inc.	295.83
53100	349	Printing, Stationery And Forms	04/09/2026	1010284816	Shred-It	30.00
53100	349	Printing, Stationery And Forms	04/23/2026	1010284896	Shred-It	30.00

COMMISSION APPROVAL LISTING

ACCT	OB	Name	Date	Check Nbr	Description	Amount Paid
Fund: General Fund #(101)						
53100	351	Rentals	04/16/2026	1010284838	Canon Solutions America, Inc	312.23
53100	399	Other Contracted Services	04/23/2026	1010284883	Local Government Corporation	1,762.52
53100	435	Office Supplies	04/27/2026	1010284900	Amazon Capital Services, Inc.	511.98
53100	435	Office Supplies	04/30/2026	1010284916	Evans Office Supply Co	405.00
53100	709	Data Processing Equipment	04/27/2026	1010284900	Amazon Capital Services, Inc.	656.00
53100	709	Data Processing Equipment	04/30/2026	1010284940	SOS Computers, LLC	1,876.00
53100	719	Office Equipment	04/02/2026	1010284757	Lowe's	960.91
53100		Circuit Court			Check Count: 12	Total: 7,260.06
53300	317	Data Processing Services	04/23/2026	1010284876	GovConnection, Inc.	23.04
53300	317	Data Processing Services	04/30/2026	1010284922	GovConnection, Inc.	23.04
53300	320	Dues And Memberships	04/16/2026	9101001398	Wayne Douglas Collins	315.00
53300	320	Dues And Memberships	04/23/2026	9101001400	Wayne Douglas Collins	409.40
53300	435	Office Supplies	04/16/2026	1010284860	SOS Computers, LLC	999.00
53300	435	Office Supplies	04/30/2026	1010284907	CDW Government, Inc	173.24
53300	435	Office Supplies	04/30/2026	1010284916	Evans Office Supply Co	60.04
53300	709	Data Processing Equipment	04/27/2026	1010284900	Amazon Capital Services, Inc.	827.96
53300		General Sessions Court			Check Count: 8	Total: 2,830.72
53330	307	Communication	04/23/2026	1010284866	AT&T Mobility	106.21
53330	317	Data Processing Services	04/23/2026	1010284876	GovConnection, Inc.	92.16
53330	317	Data Processing Services	04/30/2026	1010284922	GovConnection, Inc.	92.16
53330	349	Printing, Stationery And Forms	04/30/2026	1010284902	Allegra - Morristown	58.70
53330	351	Rentals	04/16/2026	1010284838	Canon Solutions America, Inc	89.11
53330	399	Other Contracted Services	04/02/2026	1010284751	Herbert L Gilbert	160.00
53330	425	Gasoline	04/30/2026	1010284918	Fuelman	188.11
53330	435	Office Supplies	04/30/2026	1010284916	Evans Office Supply Co	1,652.05
53330	463	Testing	04/30/2026	1010284928	Intrinsic Interventions Inc.	6,468.65

COMMISSION APPROVAL LISTING

ACCT	OB	Name	Date	Check Nbr	Description	Amount Paid
Fund: General Fund #(101)						
53330		Drug Court			Check Count: 9	Total: 8,907.15
53400	307	Communication	04/09/2026	1010284782	AT&T	73.90
53400	334	Maintenance Agreements	04/23/2026	1010284873	CDW Government, Inc	278.24
53400	351	Rentals	04/16/2026	1010284838	Canon Solutions America, Inc	89.93
53400	355	Travel	04/16/2026	9101001396	Teresa H Carey	59.02
53400		Chancery Court			Check Count: 4	Total: 501.09
53500	307	Communication	04/23/2026	1010284866	AT&T Mobility	130.50
53500	317	Data Processing Services	04/23/2026	1010284876	GovConnection, Inc.	57.60
53500	317	Data Processing Services	04/30/2026	1010284922	GovConnection, Inc.	57.60
53500	322	Evaluation And Testing	04/23/2026	1010284882	Intrinsic Interventions Inc.	2,994.00
53500	351	Rentals	04/16/2026	1010284838	Canon Solutions America, Inc	64.97
53500		Juvenile Court			Check Count: 5	Total: 3,304.67
53900	307	Communication	04/23/2026	1010284866	AT&T Mobility	81.92
53900	351	Rentals	04/16/2026	1010284838	Canon Solutions America, Inc	61.20
53900	355	Travel	04/23/2026	9101001401	Penny Knight	466.86
53900	425	Gasoline	04/30/2026	1010284918	Fuelman	41.52
53900		Other Admin Of Justice - Mental Health			Check Count: 4	Total: 651.50
53910	307	Communication	04/23/2026	1010284866	AT&T Mobility	163.84
53910	317	Data Processing Services	04/23/2026	1010284876	GovConnection, Inc.	46.08
53910	317	Data Processing Services	04/30/2026	1010284922	GovConnection, Inc.	46.08
53910	435	Office Supplies	04/27/2026	1010284900	Amazon Capital Services, Inc.	697.75
53910		Probation Services			Check Count: 4	Total: 953.75
53920	322	Evaluation And Testing	04/09/2026	1010284812	Mountain Crest Psychological Clinic	250.00
53920	451	Uniforms	04/09/2026	1010284797	Galls, LLC	1,223.00

COMMISSION AFFIDAVIT LISTING

ACCT	OB	Name	Date	Check Nbr	Description	Amount Paid
Fund: General Fund #(101)						
53920	451	Uniforms	04/09/2026	1010284828	TruBlu Tactical Police Supply	169.99
53920	451	Uniforms	04/30/2026	1010284947	TruBlu Tactical Police Supply	479.94
53920	716	Law Enforcement Equipment	04/16/2026	1010284844	Gulf States Distributors	1,252.00
53920		Courtroom Security		Check Count: 5	Total:	3,374.93
54110	302	Advertising	04/30/2026	1010284935	Morristown Signs, Inc	370.00
54110	307	Communication	04/02/2026	1010284776	Verizon Wireless	1,190.00
54110	307	Communication	04/09/2026	1010284782	AT&T	1,241.43
54110	307	Communication	04/16/2026	1010284837	AT&T Mobility	1,535.46
54110	317	Data Processing Services	04/23/2026	1010284876	GovConnection, Inc.	865.59
54110	317	Data Processing Services	04/30/2026	1010284922	GovConnection, Inc.	865.15
54110	320	Dues And Memberships	04/23/2026	1010284898	TN Sheriffs' Association, Inc	100.00
54110	320	Dues And Memberships	04/30/2026	1010284945	TN Sheriffs' Association, Inc	2,500.00
54110	338	Maintenance And Repair Services - Vehicles	04/02/2026	1010284749	Farris Jeep Ram Chrysler Dodge	684.36
54110	338	Maintenance And Repair Services - Vehicles	04/02/2026	1010284758	M & M Body Shop	235.96
54110	338	Maintenance And Repair Services - Vehicles	04/02/2026	1010284765	RJK Automotive Enterprises Inc	2,095.30
54110	338	Maintenance And Repair Services - Vehicles	04/02/2026	1010284779	Xtreme Towing & Automotive Collision Center	4,509.91
54110	338	Maintenance And Repair Services - Vehicles	04/09/2026	1010284819	Spotless Brands Intermediate I, LLC	515.00
54110	338	Maintenance And Repair Services - Vehicles	04/09/2026	1010284831	Valvoline, Inc.	47.23
54110	338	Maintenance And Repair Services - Vehicles	04/23/2026	1010284893	RJK Automotive Enterprises Inc	2,044.91
54110	338	Maintenance And Repair Services - Vehicles	04/27/2026	1010284900	Amazon Capital Services, Inc.	47.49
54110	338	Maintenance And Repair Services - Vehicles	04/30/2026	1010284917	Express Lane West / Express Lane East	69.99
54110	351	Rentals	04/09/2026	1010284822	T.E.G. Enterprises, Inc	85.00
54110	351	Rentals	04/16/2026	1010284838	Canon Solutions America, Inc	79.45
54110	353	Towing Services	04/09/2026	1010284821	Sunset Towing	110.00
54110	355	Travel	04/16/2026	1010284848	HomeTrust Bank	-248.04
54110	399	Other Contracted Services	04/09/2026	1010284826	Transunion Risk & Alternative	100.00

COMMISSION APPROVAL LISTING

ACCT	OB	Name	Date	Check Nbr	Description	Amount Paid
Fund: General Fund #(101)						
54110	399	Other Contracted Services	04/16/2026	1010284857	Murrell Burglar Alarm Co Inc	29.00
54110	425	Gasoline	04/30/2026	1010284918	Fuelman	12,776.28
54110	431	Law Enforcement Supplies	04/27/2026	1010284900	Amazon Capital Services, Inc.	478.01
54110	431	Law Enforcement Supplies	04/30/2026	1010284930	Law Enforcement Systems, Inc	331.00
54110	433	Lubricants	04/30/2026	1010284917	Express Lane West / Express Lane East	508.36
54110	435	Office Supplies	04/27/2026	1010284900	Amazon Capital Services, Inc.	339.09
54110	435	Office Supplies	04/02/2026	9101001385	Wesley A Blevins	37.96
54110	435	Office Supplies	04/09/2026	9101001393	Wesley A Blevins	30.39
54110	450	Tires And Tubes	04/02/2026	1010284764	Porter's Tire Store Inc.	435.40
54110	450	Tires And Tubes	04/30/2026	1010284939	Porter's Tire Store Inc.	30.50
54110	451	Uniforms	04/09/2026	1010284828	TruBlu Tactical Police Supply	629.93
54110	499	Other Supplies And Materials	04/27/2026	1010284900	Amazon Capital Services, Inc.	-150.00
54110	599	Other Charges	04/02/2026	1010284741	Cherokee Boat Dock LLC	110.00
54110	599	Other Charges	04/02/2026	1010284754	Hamblen County Clerk	27.00
54110	599	Other Charges	04/02/2026	1010284760	Murrell Burglar Alarm Co Inc	4,889.80
54110	599	Other Charges	04/09/2026	1010284816	Shred-It	30.00
54110	599	Other Charges	04/16/2026	1010284848	HomeTrust Bank	346.97
54110	599	Other Charges	04/27/2026	1010284900	Amazon Capital Services, Inc.	9.50
54110	599	Other Charges	04/30/2026	1010284910	Cherokee Boat Dock LLC	110.00
54110	716	Law Enforcement Equipment	04/02/2026	1010284752	Gulf States Distributors	670.00
54110	716	Law Enforcement Equipment	04/02/2026	1010284759	Metro Communications	2,013.00
54110	716	Law Enforcement Equipment	04/09/2026	1010284781	American Barcode and RFID	2,126.20
54110	716	Law Enforcement Equipment	04/09/2026	1010284815	Precision Delta Corporation	1,829.98
54110	716	Law Enforcement Equipment	04/16/2026	1010284844	Gulf States Distributors	187.60
54110	716	Law Enforcement Equipment	04/23/2026	1010284877	Gulf States Distributors	1,690.00
54110	716	Law Enforcement Equipment	04/23/2026	1010284884	Med Express, Inc	236.00
54110	716	Law Enforcement Equipment	04/23/2026	1010284885	Metro Communications	1,525.24

COMMISSION APPROVAL LISTING

ACCT	OB	Name	Date	Check Nbr	Description	Amount Paid
Fund: General Fund #(101)						
54110	716	Law Enforcement Equipment	04/23/2026	1010284891	Palmetto State Armory LLC	327.34
54110	716	Law Enforcement Equipment	04/27/2026	1010284900	Amazon Capital Services, Inc.	301.40
54110	716	Law Enforcement Equipment	04/30/2026	1010284903	American Barcode and RFID	4,211.20
54110	716	Law Enforcement Equipment	04/30/2026	1010284927	Intoximeters Inc	2,055.00
54110		Sheriff's Department			Check Count: 46	Total: 57,216.34
54120	355	Travel	04/30/2026	1010284937	Music Road Inn	15,996.46
54120		Special Patrols			Check Count: 1	Total: 15,996.46
54160	309	Contracts With Government Agencies	04/09/2026	1010284825	TN Bureau Of Investigation	1,350.00
54160	435	Office Supplies	04/27/2026	1010284900	Amazon Capital Services, Inc.	21.99
54160		Administration Of The Sexual Offender			Check Count: 2	Total: 1,371.99
54210	317	Data Processing Services	04/23/2026	1010284876	GovConnection, Inc.	108.11
54210	317	Data Processing Services	04/30/2026	1010284922	GovConnection, Inc.	108.11
54210	335	Maintenance And Repair Service - Buildings	04/02/2026	1010284743	Cumberland Glass Company LLC	250.00
54210	335	Maintenance And Repair Service - Buildings	04/02/2026	1010284757	Lowe's	93.19
54210	335	Maintenance And Repair Service - Buildings	04/09/2026	1010284834	Wholesale Supply Group	5.14
54210	335	Maintenance And Repair Service - Buildings	04/16/2026	1010284843	Fenco Supply Co	750.01
54210	335	Maintenance And Repair Service - Buildings	04/16/2026	1010284864	Wholesale Supply Group	19.82
54210	335	Maintenance And Repair Service - Buildings	04/23/2026	1010284892	Relief Septic Repair & Service Inc.	1,700.00
54210	335	Maintenance And Repair Service - Buildings	04/23/2026	1010284894	Roto-Rooter	720.00
54210	335	Maintenance And Repair Service - Buildings	04/30/2026	1010284914	Darien DeMayo	106.00
54210	335	Maintenance And Repair Service - Buildings	04/30/2026	1010284926	Home Depot Credit Services	402.79
54210	335	Maintenance And Repair Service - Buildings	04/30/2026	1010284943	TMS - Marlin	1,606.80
54210	336	Maintenance And Repair Services - Equipment	04/30/2026	1010284929	Large Equipment Inc	345.00
54210	340	Medical And Dental Services	04/02/2026	1010284746	East Tennessee Pathology PPLC	67.12
54210	340	Medical And Dental Services	04/02/2026	1010284747	East TN Center for Orthopaedic Excellence	197.58

COMMISSION APPROVAL LISTING

ACCT	OB	Name	Date	Check Nbr	Description	Amount Paid
Fund: General Fund #(101)						
54210	340	Medical And Dental Services	04/02/2026	1010284755	High Risk Obstetrical Consultants, PLLC	859.50
54210	340	Medical And Dental Services	04/02/2026	1010284768	Southeastern Emergency Physicians	153.27
54210	340	Medical And Dental Services	04/02/2026	1010284769	Summit Medical Group, PLLC	375.00
54210	340	Medical And Dental Services	04/02/2026	1010284777	Vista Radiology	555.80
54210	340	Medical And Dental Services	04/09/2026	1010284818	Southern Health Partners	62,812.66
54210	340	Medical And Dental Services	04/16/2026	1010284842	Emergency Coverage Corporation	2,974.80
54210	340	Medical And Dental Services	04/16/2026	1010284847	Healthstar Physicians, Inc	206.25
54210	340	Medical And Dental Services	04/16/2026	1010284848	HomeTrust Bank	117.00
54210	340	Medical And Dental Services	04/16/2026	1010284854	Mobile Images Acquisition LLC	1,450.00
54210	340	Medical And Dental Services	04/16/2026	1010284856	Morristown-Hamblen Hospital	4,204.58
54210	340	Medical And Dental Services	04/16/2026	1010284862	University Of TN Medical Center	18,074.62
54210	340	Medical And Dental Services	04/16/2026	1010284863	Vista Radiology	731.50
54210	340	Medical And Dental Services	04/23/2026	1010284889	Morristown-Hamblen Hospital	4,545.89
54210	340	Medical And Dental Services	04/30/2026	1010284915	East Tennessee Pathology PPLC	167.62
54210	340	Medical And Dental Services	04/30/2026	1010284934	Morristown Heart, PLLC	900.00
54210	340	Medical And Dental Services	04/30/2026	1010284949	Vista Radiology	450.10
54210	351	Rentals	04/09/2026	1010284822	T.E.G. Enterprises, Inc	150.00
54210	355	Travel	04/30/2026	9101001408	William D Hart	473.00
54210	355	Travel	04/30/2026	9101001409	Teresa Laws	473.00
54210	355	Travel	04/30/2026	9101001410	Joshua Steven Marsee	473.00
54210	410	Custodial Supplies	04/09/2026	1010284832	Wet Washing Equipment Technologies	12,038.28
54210	413	Drugs And Medical Supplies	04/16/2026	1010284848	HomeTrust Bank	634.65
54210	422	Food Supplies	04/09/2026	1010284827	Trinity Services Group, Inc.	26,197.16
54210	435	Office Supplies	04/09/2026	1010284808	Morristown Signs, Inc	75.00
54210	435	Office Supplies	04/27/2026	1010284900	Amazon Capital Services, Inc.	0.00**
54210	435	Office Supplies	04/30/2026	1010284902	Allegra - Morristown	246.96
54210	435	Office Supplies	04/30/2026	1010284916	Evans Office Supply Co	861.90

**Order to Amazon and returned for credit - net of zero.

COMMISSION APPROVAL LISTING

ACCT	OB	Name	Date	Check Nbr	Description	Amount Paid
Fund: General Fund #(101)						
54210	441	Prisoners Clothing	04/09/2026	1010284784	Bob Barker Company, Inc	7,174.41
54210	451	Uniforms	04/02/2026	1010284773	TruBlu Tactical Police Supply	1,679.76
54210	451	Uniforms	04/23/2026	1010284875	Daniel L Collins	100.00
54210	451	Uniforms	04/27/2026	1010284900	Amazon Capital Services, Inc.	320.25
54210	451	Uniforms	04/30/2026	9101001407	Sharon E Bunch	100.00
54210	599	Other Charges	04/09/2026	1010284816	Shred-It	45.00
54210	599	Other Charges	04/16/2026	1010284838	Canon Solutions America, Inc	91.92
54210	710	Food Service Equipment	04/09/2026	1010284784	Bob Barker Company, Inc	1,160.92
54210	710	Food Service Equipment	04/09/2026	1010284833	Whaley Foodservice LLC	329.50
54210	716	Law Enforcement Equipment	04/23/2026	1010284870	Blackfox, LLC	270.00
54210	716	Law Enforcement Equipment	04/27/2026	1010284900	Amazon Capital Services, Inc.	370.21
54210	716	Law Enforcement Equipment	04/30/2026	1010284905	Blackfox, LLC	1,900.00
54210	716	Law Enforcement Equipment	04/30/2026	1010284906	Bob Barker Company, Inc	1,412.12
54210	716	Law Enforcement Equipment	04/30/2026	1010284907	CDW Government, Inc	69.56
54210	716	Law Enforcement Equipment	04/30/2026	1010284931	Metro Communications	5,710.00
54210	790	Other Equipment	04/27/2026	1010284900	Amazon Capital Services, Inc.	1,111.06
54210	Jail			Check Count: 53	Total:	168,525.92
54250	307	Communication	04/23/2026	1010284866	AT&T Mobility	122.88
54250	317	Data Processing Services	04/23/2026	1010284876	GovConnection, Inc.	57.60
54250	317	Data Processing Services	04/30/2026	1010284922	GovConnection, Inc.	57.60
54250	338	Maintenance And Repair Services - Vehicles	04/09/2026	1010284819	Spotless Brands Intermediate I, LLC	30.00
54250	338	Maintenance And Repair Services - Vehicles	04/30/2026	1010284917	Express Lane West / Express Lane East	59.40
54250	399	Other Contracted Services	04/09/2026	1010284820	Stepping Out Ministries	80.00
54250	425	Gasoline	04/30/2026	1010284918	Fuelman	263.05
54250	435	Office Supplies	04/27/2026	1010284900	Amazon Capital Services, Inc.	29.60
54250	Work Release Program			Check Count: 8	Total:	700.13

COMMISSION APPROVAL LISTING

ACCT	OB	Name	Date	Check Nbr	Description	Amount Paid
Fund: General Fund #(101)						
54310	316	Contributions	04/02/2026	1010284745	East Hamblen County VFD	37,500.00
54310	316	Contributions	04/02/2026	1010284763	North Hamblen County VFD	37,500.00
54310	316	Contributions	04/02/2026	1010284767	South Hamblen County VFD	37,500.00
54310	316	Contributions	04/02/2026	1010284778	West Hamblen County VFD	37,500.00
54310		Fire Prevention And Control		Check Count: 4	Total:	150,000.00
54410	307	Communication	04/23/2026	1010284866	AT&T Mobility	77.24
54410	317	Data Processing Services	04/23/2026	1010284876	GovConnection, Inc.	46.08
54410	317	Data Processing Services	04/30/2026	1010284922	GovConnection, Inc.	46.08
54410	338	Maintenance And Repair Services - Vehicles	04/09/2026	1010284819	Spotless Brands Intermediate I, LLC	15.00
54410	355	Travel	04/16/2026	1010284848	HomeTrust Bank	850.00
54410	425	Gasoline	04/30/2026	1010284918	Fuelman	326.20
54410	599	Other Charges	04/30/2026	1010284907	CDW Government, Inc	69.56
54410	599	Other Charges	04/30/2026	1010284919	Galls, LLC	258.37
54410	708	Communication Equipment	04/16/2026	1010284848	HomeTrust Bank	199.08
54410		Civil Defense		Check Count: 8	Total:	1,887.61
54490	316	Contributions	04/09/2026	1010284800	Hamblen County E.C.D. / 911	67,688.00
54490	316	Contributions	04/09/2026	1010284807	Morristown Hamblen Emergency Rescue Squad	73,892.00
54490		Other Emergency Management		Check Count: 2	Total:	141,580.00
54610	307	Communication	04/23/2026	1010284866	AT&T Mobility	371.14
54610	312	Contracts With Private Agencies	04/16/2026	1010284851	Knox County Medical Examiner	2,075.00
54610	312	Contracts With Private Agencies	04/16/2026	1010284861	Tri-Star Removal and Transportation LLC	250.00
54610	317	Data Processing Services	04/23/2026	1010284876	GovConnection, Inc.	115.20
54610	317	Data Processing Services	04/30/2026	1010284922	GovConnection, Inc.	115.20
54610	341	Pauper Burials	04/16/2026	1010284835	Allen Funeral Home Inc	650.00
54610	399	Other Contracted Services	04/23/2026	1010284865	Daniel Allison	283.25

COMMISSION APPROVAL LISTING

ACCT	OB	Name	Date	Check Nbr	Description	Amount Paid
Fund: General Fund #(101)						
54610	399	Other Contracted Services	04/23/2026	1010284868	Travis Barner	169.95
54610	399	Other Contracted Services	04/23/2026	1010284872	Kevin Carroll	1,169.05
54610	399	Other Contracted Services	04/23/2026	1010284880	Jeffrey E. Holt	339.90
54610	399	Other Contracted Services	04/23/2026	1010284881	Amanda Beth Hopkins	309.00
54610	399	Other Contracted Services	04/23/2026	1010284897	Claude Thompson JR	731.30
54610	399	Other Contracted Services	04/02/2026	9101001391	Tom C Thompson MD	2,500.00
54610		Medical Examiner		Check Count:	13	Total: 9,078.99
54710	307	Communication	04/23/2026	1010284866	AT&T Mobility	103.67
54710	349	Printing, Stationery And Forms	04/30/2026	1010284902	Allegra - Morristown	58.70
54710	399	Other Contracted Services	04/23/2026	1010284879	Health Connect America, Inc	18,503.40
54710		Drug Court Expansion - Public Safety Grant		Check Count:	3	Total: 18,665.77
54900	790	Other Equipment	04/30/2026	1010284912	Craig's Firearm Supply	454.00
54900		Other Public Safety		Check Count:	1	Total: 454.00
55110	307	Communication	04/09/2026	1010284782	AT&T	269.27
55110	328	Janitorial Services	04/02/2026	1010284766	Roberts Cleaning Company	2,075.00
55110	355	Travel	04/02/2026	9101001381	Caroline M Aguilar	65.25
55110	355	Travel	04/02/2026	9101001384	Jennifer A Antrican	131.23
55110	355	Travel	04/02/2026	9101001387	Carrie L Farris	165.30
55110	355	Travel	04/02/2026	9101001388	Janice D Messer	7.97
55110	355	Travel	04/02/2026	9101001389	Kim Smith	40.24
55110	355	Travel	04/02/2026	9101001390	Shamron D Stambaugh	189.99
55110	452	Utilities	04/23/2026	1010284867	Atmos Energy	176.04
55110	452	Utilities	04/30/2026	1010284936	Morristown Utilities	1,428.00
55110	599	Other Charges	04/16/2026	1010284848	HomeTrust Bank	195.74

COMMISSION APPROVAL LISTING

ACCT	OB	Name	Date	Check Nbr	Description	Amount Paid
Fund: General Fund #(101)						
55110		Local Health Center		Check Count:	11	Total: 4,744.03
55120	307	Communication	04/23/2026	1010284866	AT&T Mobility	154.48
55120	312	Contracts With Private Agencies	04/09/2026	1010284810	Morristown-Hamblen Humane Soc	25,000.00
55120	317	Data Processing Services	04/23/2026	1010284876	GovConnection, Inc.	23.04
55120	317	Data Processing Services	04/30/2026	1010284922	GovConnection, Inc.	23.04
55120	338	Maintenance And Repair Services - Vehicles	04/02/2026	1010284748	Express Lane West / Express Lane East	60.36
55120	338	Maintenance And Repair Services - Vehicles	04/09/2026	1010284819	Spotless Brands Intermediate I, LLC	30.00
55120	338	Maintenance And Repair Services - Vehicles	04/30/2026	1010284917	Express Lane West / Express Lane East	59.40
55120	425	Gasoline	04/30/2026	1010284918	Fuelman	419.10
55120	435	Office Supplies	04/27/2026	1010284900	Amazon Capital Services, Inc.	167.22
55120		Rabies And Animal Control		Check Count:	9	Total: 25,936.64
56700	307	Communication	04/02/2026	1010284761	MUS Fibernet	82.26
56700	307	Communication	04/23/2026	1010284866	AT&T Mobility	84.46
56700	317	Data Processing Services	04/23/2026	1010284876	GovConnection, Inc.	11.52
56700	317	Data Processing Services	04/30/2026	1010284922	GovConnection, Inc.	11.52
56700	336	Maintenance And Repair Services - Equipment	04/02/2026	1010284744	Curt's Ace Hardware	253.91
56700	336	Maintenance And Repair Services - Equipment	04/02/2026	1010284757	Lowe's	1,235.20
56700	336	Maintenance And Repair Services - Equipment	04/09/2026	1010284791	Curt's Ace Hardware	173.96
56700	336	Maintenance And Repair Services - Equipment	04/16/2026	1010284848	HomeTrust Bank	186.56
56700	336	Maintenance And Repair Services - Equipment	04/30/2026	1010284913	Curt's Ace Hardware	209.93
56700	410	Custodial Supplies	04/23/2026	1010284869	Big M Janitorial	417.17
56700	412	Diesel Fuel	04/23/2026	1010284899	Voyager Fleet Systems Inc	115.37
56700	415	Electricity	04/09/2026	1010284809	Morristown Utilities	4,251.00
56700	415	Electricity	04/16/2026	1010284836	Appalachian Electric Co-Op	60.46
56700	425	Gasoline	04/23/2026	1010284899	Voyager Fleet Systems Inc	318.59
56700	451	Uniforms	04/02/2026	1010284738	BK Graphics LLC	379.20

COMMISSION AFFIDAVIT LISTING

Page: 17

Date/Time: 5/4/2026 9:30:40 AM

ACCT	OB	Name	Date	Check Nbr	Description	Amount Paid
Fund: General Fund #(101)						
56700	451	Uniforms	04/27/2026	1010284900	Amazon Capital Services, Inc.	218.68
56700	454	Water And Sewer	04/09/2026	1010284809	Morristown Utilities	2,262.00
56700	599	Other Charges	04/23/2026	1010284895	Dylan Samples	184.00
56700		Parks And Fair Boards			Check Count: 16	Total: 10,455.79
56900	316	Contributions	04/09/2026	1010284786	City of Morristown	75,000.00
56900		Other Social, Cultural And Recreational			Check Count: 1	Total: 75,000.00
57100	140	Salary Supplements	04/30/2026	1010284941	Tennessee State University	7,905.18
57100	435	Office Supplies	04/16/2026	1010284850	International Association of Administrative	150.00
57100		Agricultural Extension Service			Check Count: 2	Total: 8,055.18
57800	399	Other Contracted Services	04/02/2026	1010284774	Robert Tucker	139.98
57800	399	Other Contracted Services	04/30/2026	1010284921	LLC GEO Services	1,945.00
57800	429	Instructional Supplies And Materials	04/30/2026	1010284942	Tennessee Stormwater Association	222.10
57800		Storm Water Management			Check Count: 3	Total: 2,307.08
58110	316	Contributions	04/09/2026	1010284806	Morristown Area Chamber Of Commerce	11,250.00
58110	399	Other Contracted Services	04/09/2026	1010284802	JJA Enterprises Inc	26,500.00
58110		Tourism			Check Count: 2	Total: 37,750.00
58120	316	Contributions	04/09/2026	1010284803	Joint Morristown Hamblen Economic & Comm.	40,500.00
58120		Industrial Development			Check Count: 1	Total: 40,500.00
58300	317	Data Processing Services	04/23/2026	1010284876	GovConnection, Inc.	11.52
58300	317	Data Processing Services	04/30/2026	1010284922	GovConnection, Inc.	11.52
58300		Veterans' Services			Check Count: 2	Total: 23.04
58600	202	Handling Charges & Administrative Costs	04/02/2026	1010284770	TASC - Client Invoices	233.85
58600	299	Other Fringe Benefits	04/16/2026	1010284845	Hamblen Co Dept Of Education	100.00

COMMISSION APPROVAL LISTING

Page: 18
Date/Time: 5/4/2026 9:30:40 AM

ACCT	OB	Name	Date	Check Nbr	Description	Amount Paid
Fund: General Fund #(101)						
58600		Employee Benefits			Check Count: 2	Total: 333.85
91140	304	Architects	04/09/2026	1010284783	Barber McMurry Architects	6,899.15
91140	707	Building Improvements	04/09/2026	1010284787	Construction Partners, LLC	2,128.50
91140	707	Building Improvements	04/09/2026	1010284788	Construction Partners, LLC	10,552.05
91140	707	Building Improvements	04/09/2026	1010284789	Construction Partners, LLC	200,488.95
91140	707	Building Improvements	04/09/2026	1010284790	Construction Partners, LLC	40,441.50
91140		Public Health And Welfare Projects			Check Count: 5	Total: 260,510.15
General Fund #(101) Total:						1,274,671.22

May 21, 2026

COMMISSION APPROVAL LISTING

Page: 1
Date/Time: 5/4/2026 9:31:38 AM

ACCT	OB	Name	Date	Check Nbr	Description	Amount Paid
Fund: Drug Control Fund #(122)						
54150	140	Salary Supplements	04/23/2026	1220003085	Hamblen County Government	3,000.00
54150	201	Social Security	04/23/2026	1220003085	Hamblen County Government	186.00
54150	204	State Retirement	04/23/2026	1220003085	Hamblen County Government	315.00
54150	212	Employer Medicare	04/23/2026	1220003085	Hamblen County Government	43.50
54150	351	Rentals	04/09/2026	1220003083	T.E.G. Enterprises, Inc	65.00
54150	401	Animal Food And Supplies	04/16/2026	1220003084	HomeTrust Bank	75.98
54150	415	Electricity	04/09/2026	1220003082	MUS Fibernet	102.37
54150		Drug Enforcement			Check Count: 4	Total: 3,787.85
Drug Control Fund #(122) Total:						3,787.85

May 21, 2026

COMMISSION APPROVAL LISTING

ACCT	OB	Name	Date	Check Nbr	Description	Amount Paid
Fund: Drug Use Abatement Fund						
55130	316	Contributions	04/09/2026	1280000027	Morristown Hamblen Emergency Rescue Squad	133,608.00
55130		Ambulance/Emergency Medical Se			Check Count: 1	Total: 133,608.00
Drug Use Abatement Fund Total:						133,608.00

May 21, 2026

COMMISSION APPROVAL LISTING

Page: 1
Date/Time: 5/4/2026 9:32:35 AM

ACCT	OB	Name	Date	Check Nbr	Description	Amount Paid
Fund: General Debt Service Fund #(151)						
82110	612	Principal On Other Loans	04/09/2026	1510000076	Appalachian Electric Co-Op	3,333.33
82110		General Government			Check Count: 1	Total: 3,333.33
82330	699	Other Debt Service	04/09/2026	9151000011	Regions Bank	500.00
82330	699	Other Debt Service	04/30/2026	9151000012	Cumberland Securities Co, Inc	2,500.00
82330		Education			Check Count: 2	Total: 3,000.00
General Debt Service Fund #(151) Total:						6,333.33

May 21, 2026

COMMISSION APPROVAL LISTING

Page: 2
Date/Time: 5/4/2026 9:32:35 AM

ACCT	OB	Name	Date	Check Nbr	Description	Amount Paid
Fund: General Capital Projects Fund #(171)						
91140	791	Other Construction	04/09/2026	1710001806	Carl L Gibson JR	62,300.00
91140	791	Other Construction	04/09/2026	1710001807	TN Community Assistance Corporation	17.00
91140	791	Other Construction	04/09/2026	1710001808	Volunteer Home Solutions	1,000.00
91140	791	Other Construction	04/09/2026	1710001809	John Christopher Zachary	2,500.00
91140	791	Other Construction	04/16/2026	1710001810	TN Community Assistance Corporation	20,000.00
91140		Public Health And Welfare Projects		Check Count:	5	Total: 85,817.00
General Capital Projects Fund #(171) Total:						85,817.00

May 21, 2026

COMMISSION APPROVAL LISTING

ACCT	OB	Name	Date	Check Nbr	Description	Amount Paid
Fund: Highway Capital Projects Fund #(176)						
91200	404	Asphalt - Hot Mix	04/16/2026	1760001154	Blalock & Sons Inc	8,765.90
91200	409	Crushed Stone	04/09/2026	1760001153	Vulcan Materials Company	5,729.64
91200		Highway And Street Capital Projects			Check Count: 2	Total: 14,495.54
Highway Capital Projects Fund #(176) Total:						14,495.54

May 21, 2026

COMMISSION APPROVAL LISTING

Page: 4
Date/Time: 5/4/2026 9:32:35 AM

ACCT	OB	Name	Date	Check Nbr	Description	Amount Paid
Fund: Other Capital Projects Fund/Fu						
91170	791	Other Construction	04/16/2026	1780000016	Witt Utility District	345,485.25
91170		Public Utility Projects			Check Count: 1	Total: 345,485.25
Other Capital Projects Fund/Fu Total:						345,485.25

May 21, 2026

COMMISSION APPROVAL LISTING

ACCT	OB	Name	Date	Check Nbr	Description	Amount Paid
Fund: Other Capital Projects Fund # (189)						
91130	399	Other Contracted Services	04/02/2026	1890000236	Morristown Signs, Inc	879.00
91130	399	Other Contracted Services	04/27/2026	1890000240	Amazon Capital Services, Inc.	680.65
91130	399	Other Contracted Services	04/30/2026	1890000242	Deacon Foodservice Solutions, LLC	0.00 **
91130	711	Furniture And Fixtures	04/02/2026	1890000237	Tab Office Environment	3,775.00
91130	711	Furniture And Fixtures	04/09/2026	1890000238	Metro Communications	20,270.62
91130	711	Furniture And Fixtures	04/09/2026	1890000239	Tab Office Environment	4,835.00
91130	711	Furniture And Fixtures	04/27/2026	1890000240	Amazon Capital Services, Inc.	4,685.53
91130	711	Furniture And Fixtures	04/30/2026	1890000241	BOE-TEL ETN Company, LLC	4,971.00
91130		Public Safety Projects		Check Count:	7	Total: 40,096.80
Other Capital Projects Fund # (189) Total:						40,096.80

May 21, 2026

**Prior year P.O. #1892300002 for food service equipment for the new Justice Center \$20,971.25

COMMISSION APPROVAL LISTING

Date/Time: 5/4/2026 9:32:35 AM Page: 6

ACCT	OB	Name	Date	Check Nbr	Description	Amount Paid
Fund: Employee Insurance - General Fund#(264)						
58600	312	Contracts With Private Agencies	04/09/2026	2640002050	LLC STP	1,850.00
58600	312	Contracts With Private Agencies	04/16/2026	2640002051	Carehere LLC	28,215.90
58600	312	Contracts With Private Agencies	04/16/2026	2640002052	Murrell Burglar Alarm Co Inc	38.00
58600	312	Contracts With Private Agencies	04/23/2026	2640002053	Atmos Energy	64.02
58600	312	Contracts With Private Agencies	04/23/2026	2640002054	Morristown Utilities	277.00
58600		Employee Benefits		Check Count: 5	Total:	30,444.92
Employee Insurance - General Fund#(264) Total:						30,444.92

May 21, 2026

COMMISSION APPROVAL LISTING

ACCT	OB	Name	Date	Check Nbr	Description	Amount Paid
Fund: Solid Waste/Sanitation Fund #(116)						
55710	307	Communication	04/02/2026	1160025918	Comcast Cable	53.45
55710	307	Communication	04/09/2026	1160025920	AT&T	73.90
55710	307	Communication	04/16/2026	1160025927	AT&T Mobility	62.71
55710	307	Communication	04/30/2026	1160025942	Comcast Cable	53.45
55710	312	Contracts With Private Agencies	04/23/2026	1160025935	Cintas Corp., Loc. 207	1,254.90
55710	336	Maintenance And Repair Services - Equipment	04/09/2026	1160025922	Kimball Midwest	165.93
55710	336	Maintenance And Repair Services - Equipment	04/09/2026	1160025923	Premier Truck Group	1,173.18
55710	336	Maintenance And Repair Services - Equipment	04/09/2026	1160025924	Southern Fluidpower, Inc.	196.91
55710	336	Maintenance And Repair Services - Equipment	04/09/2026	1160025926	Worldwide Equipment, Inc.	6,967.90
55710	336	Maintenance And Repair Services - Equipment	04/16/2026	1160025929	Combs Equipment Group LLC	1,915.00
55710	336	Maintenance And Repair Services - Equipment	04/16/2026	1160025931	Dustin Lumpkins	450.00
55710	336	Maintenance And Repair Services - Equipment	04/16/2026	1160025932	NAPA Auto Parts Of Morristown	1,658.93
55710	353	Towing Services	04/30/2026	1160025945	Malone's Wrecker Service	12,000.00
55710	359	Disposal Fees	04/23/2026	1160025936	Hamblen County-Morristown Solid Waste	125,381.40
55710	412	Diesel Fuel	04/30/2026	1160025944	Fuelman	21,540.99
55710	415	Electricity	04/23/2026	1160025937	Holston Electric Cooperative	576.93
55710	425	Gasoline	04/30/2026	1160025944	Fuelman	413.67
55710	435	Office Supplies	04/27/2026	1160025940	Amazon Capital Services, Inc.	41.02
55710	450	Tires And Tubes	04/16/2026	1160025930	Goforth Tire & Auto, Inc	11,884.91
55710	451	Uniforms	04/09/2026	1160025925	Unifirst Corp	481.52
55710	451	Uniforms	04/23/2026	1160025935	Cintas Corp., Loc. 207	96.40
55710	454	Water And Sewer	04/23/2026	1160025939	Morristown Utilities	73.50
55710	499	Other Supplies And Materials	04/23/2026	1160025938	Gregory Reece Manis	85.00
55710	499	Other Supplies And Materials	04/30/2026	1160025943	Fish Window Cleaning	110.00
55710	515	Liability Claims	04/16/2026	1160025934	Weigel Stores Inc	990.00

COMMISSION APPROVAL LISTING

ACCT	OB	Name	Date	Check Nbr	Description	Amount Paid
Fund: Solid Waste/Sanitation Fund #(116)						
55710	712	Heating and Air Conditioning Equipment	04/30/2026	1160025947	Nies Mechanical LLC	7,000.00
55710		Sanitation Management			Check Count: 24	Total: 194,701.60
Solid Waste/Sanitation Fund #(116) Total:						194,701.60

May 21, 2026

COMMISSION APPROVAL LISTING

ACCT	OB	Name	Date	Check Nbr	Description	Amount Paid
Fund: Highway/Public Works Fund (#131)						
61000	307	Communication	04/02/2026	1313045984	Comcast Cable	53.45
61000	307	Communication	04/09/2026	1313045988	AT&T	73.90
61000	307	Communication	04/16/2026	1313046000	AT&T Mobility	62.71
61000	307	Communication	04/30/2026	1313046014	Comcast Cable	53.45
61000	317	Data Processing Services	04/23/2026	1313046007	GovConnection, Inc.	81.37
61000	317	Data Processing Services	04/30/2026	1313046016	GovConnection, Inc.	81.37
61000	320	Dues And Memberships	04/30/2026	1313046020	TN County Services Association	500.00
61000	415	Electricity	04/02/2026	1313045985	Morristown Utilities	38.00
61000	415	Electricity	04/23/2026	1313046008	Holston Electric Cooperative	576.94
61000	415	Electricity	04/23/2026	1313046009	Morristown Utilities	2,130.00
61000	415	Electricity	04/30/2026	1313046017	Morristown Utilities	38.00
61000	435	Office Supplies	04/27/2026	1313046011	Amazon Capital Services, Inc.	119.93
61000	454	Water and Sewer	04/23/2026	1313046009	Morristown Utilities	73.50
61000	599	Other Charges	04/02/2026	1313045987	UniFirst First Aid Corp	112.17
61000	599	Other Charges	04/09/2026	1313045996	Spotless Brands Intermediate I, LLC	30.00
61000	599	Other Charges	04/23/2026	1313046006	Cintas Corp., Loc. 207	98.45
61000		Administration		Check Count: 15	Total: 4,123.24	
62000	351	Rentals	04/30/2026	1313046012	A-1 Equipment Rental	280.00
62000	426	General Construction Materials	04/16/2026	1313046004	Smoky Mountain Farmers Co-Op	743.69
62000	443	Road Signs	04/30/2026	1313046021	Vulcan Inc D/B/A Vulcan Signs	958.20
62000	444	Salt	04/09/2026	1313045993	Morton International	7,671.22
62000	451	Uniforms	04/09/2026	1313045998	Unifirst Corp	957.65
62000	451	Uniforms	04/23/2026	1313046006	Cintas Corp., Loc. 207	125.15
62000		Highway And Bridge Maintenance		Check Count: 6	Total: 10,735.91	
63100	412	Diesel Fuel	04/09/2026	1313045994	Pioneer Petroleum	1,863.42
63100	412	Diesel Fuel	04/30/2026	1313046015	Fuelman	5,095.47

COMMISSION APPROVAL LISTING

ACCT	OB	Name	Date	Check Nbr	Description	Amount Paid
Fund: Highway/Public Works Fund (#131)						
63100	416	Equipment Parts - Heavy	04/09/2026	1313045991	Interstate Battery System	251.90
63100	416	Equipment Parts - Heavy	04/09/2026	1313045995	Southern Fluidpower, Inc.	899.01
63100	416	Equipment Parts - Heavy	04/09/2026	1313045997	TriGreen Equipment	4,603.67
63100	416	Equipment Parts - Heavy	04/09/2026	1313045999	Worldwide Equipment, Inc.	1,636.36
63100	416	Equipment Parts - Heavy	04/16/2026	1313046002	NAPA Auto Parts Of Morristown	876.78
63100	416	Equipment Parts - Heavy	04/16/2026	1313046005	Stowers Machinery Corporation	1,784.04
63100	416	Equipment Parts - Heavy	04/23/2026	1313046010	Steve's Transmission	379.00
63100	424	Garage Supplies	04/09/2026	1313045990	Holston Gases	415.43
63100	425	Gasoline	04/30/2026	1313046015	Fuelman	2,973.90
63100	450	Tires And Tubes	04/16/2026	1313046001	Goforth Tire & Auto, Inc	2,530.35
63100	499	Other Supplies And Materials	04/09/2026	1313045992	Lane Sales Power Equipment	131.40
63100		Operation And Maintenance Of Equipment			Check Count: 12	Total: 23,440.73
68000	712	Heating and Air Conditioning Equipment	04/30/2026	1313046019	Nies Mechanical LLC	1,760.00
68000		Capital Outlay			Check Count: 1	Total: 1,760.00
Highway/Public Works Fund (#131) Total:						40,059.88

April 2026

Permit	Date	Applicant	Type	Address	Construction	Permit	SW	Plumbing	Mech.	Gas	Total	Tax Map	Group	Parcel
26-0119	4/1/26	Donna Vickers Hough	Carport 24x31	2702 Calvin Road	\$1,600.00	\$25.00					\$ 25.00	024		160.11
26-0120	4/1/26	Stacy Ludtke	Deck 8x25	1523 River Path	\$2,000.00	\$50.00					\$ 50.00	163G	A	044.00
26-0121	4/2/26	Connie Holdway	Garage 40x60	5524 Old Hwy 160	\$49,000.00	\$600.00					\$ 600.00	064		007.01
26-0122	4/6/26	Eván Johnson	Plumbing	4169 Harbor View Dr				\$25.00			\$ 25.00	017C	A	019.00
26-0123	4/7/26	Alejandra Castero	Carport 30 x 20	124 Caughorn Drive	\$2,000.00	\$25.00					\$ 25.00	019		072.00
26-0124	4/7/26	Claude/Susan Patterson	House	1190 Murrell Rd	\$950,000.00	\$1,861.00	\$100.00				\$ 1,961.00	040		013.07
26-0125M	4/7/26	Claude/Susan Patterson	Mechanical/Gas	1190 Murrell Rd					\$30.00	\$47.50	\$ 77.50	040		013.07
26-0126	4/8/26	William Manning	Additon/Cover	1583 Arden Lane	\$10,000.00	\$191.50					\$ 191.50	042		094.08
26-0127	4/9/26	Michael Boyd	Garage 40x60	678 Alshie Rd	\$50,000.00	\$600.00					\$ 600.00	057		005.65
26-0128	4/9/26	Robert Clause	Garage 12x22	5290 Spencor Hale rd	\$9,000.00	\$66.00					\$ 66.00	057		140.17
26-0129	4/9/26	Brandon Carpenter	Garage 14x144	5575 Carlyle Ave	\$15,000.00	\$179.00					\$ 179.00	018B	F	0130.00
26-0130	4/9/26	Will Merrill	Garage 30x50	5690 Long Creek Rd	\$30,000.00	\$375.00					\$ 375.00	062		026.01
26-0131P	4/9/26	Martinez & Handyman	Plumbing	4203 Stansberry Dr				\$105.00			\$ 105.00	035L	G	002.00
26-0132	4/10/26	Valley View Developers	House	4189 Harbor View Dr	\$200,000.00	\$1,074.10	\$100.00				\$ 1,774.10	017C	A	016.00
26-0133M	4/10/26	Valley View Developers	Mechanical	4189 Harbor View Dr					\$20.00		\$ 20.00	017C	A	016.00
26-0134P	4/10/26	Valley View Developers	Plumbing	4189 Harbor View Dr				\$115.00			\$ 115.00	017C	A	016.00
26-0135	4/10/26	Don Morrison	DWMH	2731 Cloanview Rd	\$198,550.00	\$350.00					\$ 350.00	032		154.00
26-0136	4/10/26	Jeremy Young	DWMH	7216 Mountain Valley Rd	\$170,000.00	\$350.00					\$ 350.00	028		025.00
26-0137	4/10/26	Miguel Gabriel	Storage Bldg	5902 Bernie Circle	\$5,000.00	\$64.00					\$ 64.00	054E	B	002.00
26-0138	4/13/26	Liton Properties & Deve	House	1083 Little Mountain Rd	\$601,450.00	\$1,680.00	\$100.00				\$ 1,780.00	027		011.10
26-0139P	4/13/26	Liton Properties & Deve	Mechanical	1083 Little Mountain Rd					\$20.00		\$ 20.00	027		011.10
26-0140	4/15/26	MasTec Network	Tower	1393 Bannaville Dr	\$25,000.00	\$50.00					\$ 50.00	033		004.15
26-0141	4/15/26	Richmond Construction	Additon 10x12	6283 Cotton Tail	\$25,000.00	\$60.00					\$ 60.00	047F	B	015.00
26-0142	4/17/26	Angie Coyton	Garage	1577 Rines Rd	\$8,500.00	\$160.00					\$ 160.00	046		019.01
26-0143	4/17/26	Billy & Shonda Samsel	House	4481 Old Kentucky Rd	\$405,000.00	\$1,205.00	\$100.00				\$ 1,305.00	018		087.06
26-0144	4/17/26	Billy & Shonda Samsel	Mechanical	4481 Old Kentucky Rd					\$15.00		\$ 15.00	018		087.06
26-0145	4/20/26	Eduardo Zapata	Additon/Decks	2536 Lakaview Drive	\$4,500.00	\$64.50					\$ 64.50	025		002.00
26-0146	4/20/26	Jacob Mery	House	817 Guy Collins Rd	\$195,000.00	\$800.00	\$100.00				\$ 900.00	057		006.09
26-0147M	4/20/26	Jacob Mery	Mechanical	817 Guy Collins Rd					\$15.00		\$ 15.00	057		006.09
26-0148	4/21/26	Appex	Gas	4148 Dan Dr					\$20.00		\$ 20.00			
26-0149	4/21/26	Scott Masoner	Remodel	1485 President Circle	\$120,000.00	\$400.00					\$ 400.00	047H	A	022.00
26-0150M	4/21/26	Scott Masoner	Mechanical	1485 President Circle					\$15.00		\$ 15.00	047H	A	022.00
26-0151P	4/21/26	Scott Masoner	Plumbing	1485 President Circle				\$55.00			\$ 55.00	047H	A	022.00
26-0152	4/21/26	Susan Norton	House 1810 sq ft	2695 Joanne Circle	\$300,000.00	\$1,158.00	\$100.00				\$ 1,258.00	017N	C	009.00
26-0153M	4/21/26	Susan Norton	Mechanical	2695 Joanne Circle					\$20.00		\$ 20.00	017N	C	009.00
26-0154P	4/21/26	Susan Norton	Plumbing	2695 Joanne Circle				\$95.00			\$ 95.00	017N	C	009.00
26-0155	4/21/26	Aaron Alder	Pool 24 ft above ground	1311 Spout Springs Rd	\$1,000.00	\$75.00					\$ 75.00	024		113.03
26-0156	4/22/26	Jan Harkness	Remodel	8112 W. Pointe Drive		\$250.00					\$ 250.00	053F	A	048.00
26-0157G	4/22/26	David Epps	Gas	4978 Jonalhan Drive					\$20.00		\$ 20.00	017D	D	010.00
26-0158	4/22/26	Cameron & Tiffany Halifax	In-Ground Pool	2205 Essex Lane	\$98,846.00	\$50.00					\$ 50.00	039L	C	013.00
26-0159	4/23/26	VOID #									\$ -			
26-0160	4/23/26	Kristina Volles	Deck/Cover	8410 Nicholson Rd	\$1,800.50	\$70.00					\$ 70.00	019		078.09
26-0161	4/23/26	Kathryn Cowan	Carport	1853 Central Church Rd	\$2,000.00	\$25.00					\$ 25.00	032		0
26-0162P	4/23/26	Luis Castro	Plumbing	3710 Old Enka Hwy				\$25.00			\$ 25.00	051		048.00
26-0163	4/23/26	Jorge Castellanos	Remodel	4968 Bernie Circle	\$15,000.00	\$70.00					\$ 70.00	018A	A	004.00
26-0164	4/24/26	Scott Hollifield	Carport	1940 Thompson Creek Rd	\$10,000.00	\$25.00					\$ 25.00	042		041.07
26-0165	4/24/26	Hayden Haun	Garage 36x48	2005 Courtney Rd	\$11,559.00	\$0.00					\$ -	028		043.01
26-0166	4/24/26	Josh Callahan	House	3135 Bridgewater Blvd	\$700,000.00	\$1,865.00	\$100.00				\$ 1,965.00	019		082.00
26-0167M	4/24/26	Josh Callahan	Mechanical	3135 Bridgewater Blvd					\$30.00		\$ 30.00	019		082.00
26-0168	4/27/26	Jimmie Glasscock	Attached Carport	2006 River View Dr	\$5,000.00	\$25.00					\$ 25.00	051Q	A	001.00
26-0169P	4/27/26	Noel Lopez	Plumbing	7483 Circle Point Dr				\$105.00			\$ 105.00	046D	F	012.00
26-0170	4/28/26	Clydon Hermes	DWMH	5545 Buell Street	\$148,640.00	\$350.00					\$ 350.00	055H	B	011.01
26-0171	4/28/26	Reida Dalton	Porch/Cover	1787 Silver City Rd	\$5,000.00	\$125.00					\$ 125.00	028		009.00
26-0172	4/28/26	STM Contracting LLC	House	827 Kidwell Ridge Rd	\$222,000.00	\$744.00	\$100.00				\$ 844.00	040		047.01
26-0173M	4/28/26	STM Contracting LLC	Mechanical	827 Kidwell Ridge Rd					\$20.00		\$ 20.00	040		047.01
26-0174	4/29/26	Michael Hamby	Above-Gd Pool	8162 Silver Fox Trail	\$6,500.00	\$50.00					\$ 50.00	047F	B	001.00
26-0175	4/29/26	Trent Property Company	DWMH	7901 Lebanon Church Rd	\$116,900.00	\$350.00					\$ 350.00	045		024.03
26-0176	4/29/26	Jonathan McGill	Deck/Cover	7242 CherryBrook Lane	\$2,600.00	\$71.50					\$ 71.50	047I	A	036.00
26-0177	4/29/26	Angel R. Alonso	Additon/Plumbing	862 Alpha Drive	\$40,000.00	\$190.00		\$12.50			\$ 202.50	047E	B	013.00
26-0178	4/30/26	MasTec Network	Cell Tower Upgrades	4180 Chucky River Road	\$25,000.00	\$50.00					\$ 50.00	052		002.00
26-0179	4/30/26	Martinez Handyman	House	4755 Old Kentucky Rd	\$150,000.00	\$600.00	\$100.00				\$ 700.00	018J	B	001.00
26-0180	4/30/26	Martinez Handyman	Mechanical	4755 Old Kentucky Rd					\$15.00		\$ 15.00	018J	B	001.00
26-0181	4/30/26	Martinez Handyman	Plumbing	4755 Old Kentucky Rd				\$90.00			\$ 90.00	018J	B	001.00
Total				Total:	\$4,936,445.50	\$16,393.60	\$900.00	\$627.50	\$200.00	\$87.50	\$ 18,008.60			
Running Total					\$21,000,748.26	\$84,165.25	\$5,090.00	\$5,376.00	\$1,397.50	\$51,865.04	\$ 143,508.79			
		26-0165 Hayden Haun		CHO and Miscellaneous	7	\$170.00		\$170.00				ETHRA	Monthly	YTD
		Agriculture Exempt		Re-Zoning Request				\$0.00	Grand			HCMES	0	0
				Variance Request				\$0.00	Total:		\$ 18,978.60			
		3 lots or more		Plat Approval	1	\$167.00		\$0.00						
				Land Disturbance/Development				\$0.00						
				Use on Review				\$0.00	2025-2026					
				Refunds				\$0.00	Running					
				Total Collected				\$170.00	Total:	\$150,248.79				
				Running Total Collected				\$6,741.00						

LAW OFFICES
CAPPS & BYRD LLP
1004 WEST FIRST NORTH STREET
MORRISTOWN, TENNESSEE 37814

PAUL R. CAPPS (1922-2003)
FRANK P. CANTWELL JR (Ret.)

CHRISTOPHER P. CAPPS
DAVID S. BYRD

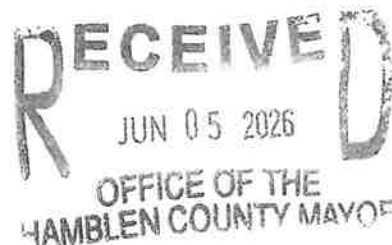

TELEPHONE: (423) 586-3083
FACSIMILE: (423) 586-0513
WEBSITE: cappsbyrdlaw.com
E-MAIL: info@cccblaw.com

June 3, 2026

Mr. Chris Cutshaw, County Mayor
Hamblen County Courthouse
511 West Second North Street
Morristown, TN 37814

**RE: INVOICES FOR LEGAL SERVICES RENDERED ON BEHALF
OF HAMBLLEN COUNTY, TENNESSEE - MAY, 2026**

Dear Chris:

Please find enclosed two (2) invoices representing legal services rendered on behalf of Hamblen County, Tennessee during the month of May, 2026.

As usual, one invoice covers our General/Miscellaneous File, and one (1) invoice covers a separate county department.

Please review these invoices, and if you have any questions, please do not hesitate to contact me.

With best regards, I remain,

Very truly yours,

A handwritten signature in cursive script that reads "Christopher P. Capps/alg".

Christopher P. Capps

CPC/alg

Enclosures

May 21, 2026

[Return to Regular Calendar](#)

Capps & Byrd, LLP

1004 W. 1st North Street
Morristown, TN 37814

INVOICE

Invoice # 1346
Date: 06/03/2026
Due On: 07/03/2026

Hamblen County Government
Hamblen County Courthouse
511 West Second North Street
Morristown, TN 37814

00027-Hamblen County Government

General Account

Type	Date	Description	Quantity	Rate	Total
Service	05/01/2026	E-mails from Edna Greene re: sign and itemization for pending litigation/public records; e-mails from Wayne NeSmith and Edna Greene re: MOU with city and county; e-mail from John Dollarhide re: pending litigation	0.20	\$175.00	\$35.00
Service	05/04/2026	Phone conference with Bill Brittain; e-mails with Linda Noe and Matt Gerdeman re: pending litigation; e-mails with Trish Bowman re: public records request	0.40	\$175.00	\$70.00
Service	05/05/2026	E-mails with Linda Noe, Matt Gerdeman, Sharee Long and Jonathan Taylor re: pending litigation	0.40	\$175.00	\$70.00
Service	05/06/2026	E-mail to Edna Greene re: itemization for pending litigation; e-mails with Dennis Fox re: fireworks; e-mail from Gavin Smelcer re: pending litigation	0.25	\$175.00	\$43.75
Service	05/07/2026	E-mail to Trish Bowman re: pending litigation; e-mail from Trish Bowman re: 5/11 committee meeting	0.10	\$175.00	\$17.50
Service	05/08/2026	E-mail from Trish Bowman re: 5/11 committee meeting; e-mails with Jonathan Taylor re: pending litigation	0.10	\$175.00	\$17.50
Service	05/11/2026	E-mail to Linda Noe re: pending litigation	0.05	\$175.00	\$8.75
Service	05/12/2026	E-mails with Linda Noe and Melyssa McCracken re: pending litigation	0.15	\$175.00	\$26.25
Service	05/13/2026	E-mail from Edna Greene re: MOU with city and county; e-mail to Linda Noe re: pending litigation	0.10	\$175.00	\$17.50
Service	05/14/2026	E-mails from and to Linda Noe re: pending litigation; e-mail from Edna Greene re: landfill	0.15	\$175.00	\$26.25

Service	Date	Description	Hours	Rate	Amount
Service	05/15/2026	E-mail from Linda Noe re: pending litigation	0.05	\$175.00	\$8.75
Service	05/18/2026	E-mail from Sue Budd re: pending litigation; e-mail David Purkey re: pending litigation	0.10	\$175.00	\$17.50
Service	05/19/2026	Phone conferences with Trish Bowman, Bill Brittain and Chris Cutshaw; e-mail from Trish Bowman re: 5/21 commission meeting; e-mails with David Purkey re: pending litigation; work on pending litigation	2.25	\$175.00	\$393.75
Service	05/20/2026	Phone conference with Trish Bowman; e-mail from Sandy Jenkins re: pending litigation; worked on pending litigation; e-mail to Linda Noe and Courtney Read re: pending litigation	1.25	\$175.00	\$218.75
Service	05/21/2026	E-mails with Courtney Read, Sharee Long, Sue Budd and Matt Gerdeman re: pending litigation; phone conferences with Bill Brittain and Chris Cutshaw	0.40	\$175.00	\$70.00
Service	05/26/2026	E-mails with Sue Budd and Linda Noe re: pending litigation	0.15	\$175.00	\$26.25
Service	05/27/2026	Conference with Bill Brittain and Chris Cutshaw; conference with Sheriff; e-mails to Jordan Lanius re: pending litigation	1.00	\$175.00	\$175.00
Service	05/28/2026	Prepare for hearing; hearing; prepare Order	4.75	\$175.00	\$831.25
Service	05/29/2026	E-mails with Jordan Lanius re: pending litigation; revise Order	0.25	\$175.00	\$43.75
				Total	\$2,117.50

Detailed Statement of Account

Current Invoice

Invoice Number	Due On	Amount Due	Payments Received	Balance Due
1346	07/03/2026	\$2,117.50	\$0.00	\$2,117.50
			Outstanding Balance	\$2,117.50
			Amount in Trust	\$0.00
			Total Amount Outstanding	\$2,117.50

Please make all amounts payable to: Capps & Byrd, LLP

Please pay within 30 days.

Capps & Byrd, LLP

1004 W. 1st North Street
Morristown, TN 37814

INVOICE

Invoice # 1343
Date: 06/02/2026
Due On: 07/02/2026

Hamblen County Government
Hamblen County Courthouse
511 West Second North Street
Morristown, TN 37814

00068-Hamblen County Planning Department

Planning

Type	Date	Description	Quantity	Rate	Total
Service	03/16/2026	E-mail from Donna Massey re: property	0.05	\$175.00	\$8.75
Service	05/05/2026	E-mail from Tommy McKinney re: property	0.05	\$175.00	\$8.75
Service	05/18/2026	E-mail to Kristy Brown	0.05	\$175.00	\$8.75
Service	05/21/2026	Phone conferences with Tommy McKinney and Edgar Gray	0.15	\$175.00	\$26.25
Service	05/22/2026	Phone conference with Tommy McKinney	0.10	\$175.00	\$17.50
Service	05/26/2026	Research; phone conferences with Tommy McKinney and Edgar Gray	0.50	\$175.00	\$87.50
Service	05/27/2026	Phone conferences with Tommy McKinney, Edgar Gray and Chris Cutshaw	0.25	\$175.00	\$43.75
				Total	\$201.25

Detailed Statement of Account

Current Invoice

Invoice Number	Due On	Amount Due	Payments Received	Balance Due	
1343	07/02/2026	\$201.25	\$0.00	\$201.25	
				Outstanding Balance	\$201.25
				Amount in Trust	\$0.00

Total Amount Outstanding **\$201.25**

Please make all amounts payable to: Capps & Byrd, LLP

Please pay within 30 days.



Financial Summary Report

Hamblen County Trustee

Printed 05/06/2026 08:25 AM By JILL MARGELOWSKY

Financial Summary Report - April 01, 2026 to April 30, 2026

Fund	Name	Starting Balance	Receipts	Disbursements	Transfers In	Transfers Out	Comm. Adj.	Commission	Ending Balance
101	GENERAL FUND	\$21,513,180.83	\$1,687,688.14	\$3,155,629.16	\$0.00	\$0.00	(\$107.45)	\$9,986.78	\$20,035,360.48
118	GARBAGE/SOLID WASTE	\$4,467,009.93	\$259,637.01	\$312,663.98	\$0.00	\$0.00	(\$0.26)	\$2,202.39	\$4,411,780.83
122	DRUG CONTROL	\$355,093.85	\$2,322.80	\$3,787.85	\$0.00	\$0.00	\$0.00	\$12.02	\$353,616.78
126	SCHOOL EMPLOYEE SELF INSURANCE	\$14,952.51	\$0.00	\$5,289.17	\$2,837.50	\$0.00	\$0.00	\$0.00	\$12,500.84
127	SCHOOL TAX ACCOUNT	\$387.47	\$3,504.60	\$3,411.19	\$0.00	\$0.00	\$0.00	\$0.00	\$480.88
128	OHIO SETTLEMENT FUND	\$2,130,043.45	\$220,455.75	\$173,608.00	\$0.00	\$0.00	\$0.00	\$0.00	\$2,176,891.20
131	HIGHWAY/PUBLIC WORKS	\$2,006,911.01	\$190,004.02	\$179,663.34	\$0.00	\$0.00	\$0.00	\$1,895.78	\$2,015,155.91
141	GENERAL PURPOSE SCHOOL	\$35,634,607.96	\$9,912,348.73	\$8,912,922.27	\$0.00	\$0.00	(\$39.45)	\$28,727.33	\$36,605,348.54
142	SCHOOL FEDERAL PROJECTS	\$1,665,010.01	\$1,159,894.54	\$832,128.92	\$0.00	\$0.00	\$0.00	\$0.00	\$1,992,775.63
143	FOOD SERVICE	\$8,140,051.66	\$1,430,815.13	\$802,714.87	\$0.00	\$0.00	\$0.00	\$0.00	\$8,768,151.92
151	GENERAL DEBT SERVICE	\$19,422,306.96	\$391,587.17	\$4,879,743.33	\$0.00	\$0.00	(\$36.04)	\$1,532.91	\$14,932,653.93
154	SPECIAL DEBT SERVICE	\$3,311,071.81	\$10,138.53	\$0.00	\$0.00	\$0.00	\$0.00	\$0.00	\$3,321,210.34
171	GENERAL CAPITAL PROJECTS	\$219,627.68	\$83,517.00	\$85,817.00	\$0.00	\$0.00	\$0.00	\$0.00	\$217,327.68
176	HIGHWAY CAPITAL PROJECTS	\$4,081,379.80	\$313,306.85	\$14,495.54	\$0.00	\$0.00	\$0.00	\$3,133.07	\$4,377,058.04
178	AMERICAN RESCUE FUNDS	\$2,944,894.74	\$366,901.14	\$345,485.25	\$0.00	\$0.00	\$0.00	\$0.00	\$3,566,310.63
189	OTHER CAPITAL PROJECTS	\$12,001,632.04	\$32,435.95	\$1,127,497.05	\$0.00	\$0.00	\$0.00	\$0.00	\$10,906,570.94
263	EMPLOYEE SELF-INSURANCE	\$2,353,608.86	\$437,003.84	\$301,503.29	\$0.00	\$0.00	\$0.00	\$0.00	\$2,489,109.41
320	FLEX MEDICAL SPENDING	\$9,107.80	\$5,732.07	\$5,732.07	\$0.00	\$0.00	\$0.00	\$0.00	\$9,107.80
351	TRUST AND AGENCY	\$0.00	\$1,526,357.04	\$1,511,093.47	\$0.00	\$0.00	\$0.00	\$15,263.57	\$0.00
999	TRUSTEE'S OFFICE	(\$15,303,662.66)	(\$62,570.65)	\$0.00	\$0.00	\$0.00	\$0.00	\$0.00	(\$15,366,233.31)
22200	OVERFLOW	\$3,829.07	\$48.76	\$29.00	\$0.00	\$0.00	\$0.00	\$0.00	\$3,848.83
28310	UNDISTRIBUTED TAXES	\$176.00	\$0.00	\$0.00	(\$414.00)	(\$414.00)	\$0.00	\$0.00	\$176.00
29900	FEE/COMMISSION	\$15,305,362.66	\$62,753.85	\$0.00	\$0.00	\$183.20	\$0.00	\$0.00	\$15,367,933.31
		\$120,276,583.42	\$18,633,882.27	\$22,653,414.75	\$2,423.50	(\$230.80)	(\$183.20)	\$62,753.85	\$116,197,134.59



Financial Summary Report

Hamblen County Trustee

Printed 05/06/2026 08:25 AM By JILL MARGELOWSKY

Property Tax Summary	Summary of Assets Beginning Balances	Starting	Debits	Credits	Summary of Assets Ending Balances
CURRENT YEAR	INVESTMENT ACCOUNTS	\$0.00	\$0.00(+)	\$0.00(-)	\$0.00
PRIOR YEAR	CASH	\$1,700.00	\$1,701,465.49(+)	\$1,701,465.49(-)	\$1,700.00
BANKRUPTCY	BANK ACCOUNTS	\$120,266,742.43	\$67,516,237.32(+)	\$71,592,638.65(-)	\$116,190,341.60
INTEREST	COMPENSATION ACCOUNT	\$0.00	\$0.00(+)	\$0.00(-)	\$0.00
	STATE TAX RELIEF	\$5,733.00	\$1,067.00(+)	\$4,115.00(-)	\$2,685.00
	UNUSED ACCOUNTS	\$0.00	\$0.00(+)	\$0.00(-)	\$0.00
	TOTAL	120274175.43	\$69,218,770.31	\$73,298,219.14	\$116,194,726.60

May 21, 2026

This report is submitted in accordance with requirements of section 5-8-505 and 67-5-1902 Tennessee Code, annotated and to the best of my knowledge and belief, accurately reflects transactions of this office April 01, 2026 through April 30, 2026

Signature: *[Handwritten Signature]*

Title: TRUSTEE

May 06, 2026

RECEIVED
MAY - 7 2026
OFFICE OF HAMBLEN
COUNTY MAYOR



STATE OF TENNESSEE, COUNTY OF HAMBLEN
I, Peggy Henderson, County Clerk, certify
that the foregoing is a true and perfect copy
of original Financial Summary Report
Filed in my office
This 6 day of May 2026
Peggy Henderson
County Clerk

**Morristown-Hamblen Emergency Medical Service
Board of Directors Meeting Report
March 25th, 2026**

The regular meeting of the Morristown-Hamblen Emergency Medical Service Board of Directors was held at 12:00pm on Wednesday, March 25th, 2026, in the north auditorium of the Rescue Squad Building.

Members present

Ralph Williams, Large Industry, Chairman
Jimmy Peoples, MERS, Treasurer
Barry Jarnagin, HCSO
Bruce Fowler, Member-At-Large
Stan Harville, Hamblen Co. Comm
Sonya Johnson, MHHS
Brian Shepard, MFD Chief
Brack Terry, Small Business
Felicia Lawson, Financial Representative

Absent

Joe Senter
Clyde short

Ex Officio Members Present

Peyton Jarnagin for Brandon Stanley, MERS Capt.
Chris Lykens, EMS Emp. Rep

Visitors

Jacob Courtney
Katie Courtney
Ricky Purkey
Cal Doty

EMS Management Staff

Danny Houseright, Director, M-H EMS
Claude Thompson, Training/ Operation Coordinator, MHEMS

- I. **Chairman Williams called the meeting to order.**
- II. **Chairman Williams called for any public comments.**
 - a. **Jacob Courtney and Katie were granted the floor to address concerns of sexual harassment. Upon completion Chairman Williams thanked them for their attendance and the willingness to speak out with their concerns as well as the rest of the board. They excused themselves.**
- III. **Chairman Williams called for motion to accept the minutes from the last meeting.**
 - a. **Motion: Brack Terry, Second: Stan Harville**
 - i. **Motion passed.**
- IV. **Chairman Williams thanked Cal Doty (HR Specialist/Investigator) for his diligence and thoroughness of the ongoing investigation of Deputy director Purkey and the MHEMS SOG's.**
- V. **Chairman Williams called for the Financial Report from Director Houseright.**
 - a. **Cash flow was down for January due to several factors such as deductibles and lower volume of runs. Company still financially strong and is working with our billing company to improve collections.**
 - i. **Chairman Williams called for a motion to accept the Financial Report**
 1. **Motion: Brack Terry, Second: Jimmy Peoples**
 2. **Motion passed.**
- VI. **Chairman Williams called for the Rescue Squad Report from Peyton Jarnagin for Captain Stanley.**
 - a. **Nothing to report.**
- VII. **Chairman Williams called for the EMS Director's Report.**
 - a. **Director Houseright presented Cal Doty to report his findings to MHEMS BOD. Out of any possible insinuation of influence, the Director and Captain Thompson excused themselves from the discussion.**

(the following portion of the minutes were recorded by Chairman Williams EMS BOD Chairman)

i.

- ii. The case involving Deputy director Purkey was discussed at length. Ultimately a motion was made to table any action pending the outcome of the State of Tennessee's Investigation and continuation of Cal Doty's investigation.
- iii. Director Houseright and Captain Thompson were invited back to the meeting.

(Following minutes were recorded by Captain Thompson)

ii. Director Houseright brought his recommendation of the two companies who sent in proposals. The decision to outsource payroll was made to go with Time and Pay.

1. Motion: Stan Harville Second: Barry Jarnigan
2. Motion Passed

b. Director Houseright highlighted the recent success of our EMS crews Jessica Poole, Morgan Hale and Bridget Powers on their accomplishments winning first place in a regional medical competition.

c. Director Houseright Request the minutes to reflect that Ramone Rodriguez be removed from all EMS financial accounts since he has been retired for a number of years and was found to still be on some of the accounts as a signer.

1. Motion: Jimmy Peoples Second: Stan Harville
2. Motion passed

d. Data (see sheet).

VIII. Captain Thompson reports that MHEMS received a grant from the State of Tennessee in the amount of \$33,303.00 for the purchase of new ventilators and video laryngoscopes.

IX. With no further business Chairman Williams adjourned the meeting.

- a. Motion: Jimmy Peoples. Second: Felicia Lawson at 1345.

CDT/DWH. 3-26-26

HAMBLEN COUNTY, TENNESSEE
OFFICE OF COUNTY MAYOR
EDUCATION & LONGEVITY PAY APPLICANT PRESENTED TO
THE PERSONNEL COMMITTEE ON
May 11, 2026

EDUCATION

Last Name	First Name	Education	Amount
Trent	Kimberly	CTE Certificate	\$350

LONGEVITY

Last Name	First Name	Hire Date	Prior Years of Employment	Amount	Years of Service
Peralez	Kayleigh	5/1/2025	2	\$225.00	3
Suggs	Dakota	10/16/2023	1	\$225.00	3

Effective June 2026, the rate for the \$20,000 Basic Life and AD&D benefit provided through US Able Life for all full-time employees will increase 7.5%, from \$2.10 to \$2.26 per employee per month. The school finance team solicited competitive bids; however, the renewal process still resulted in this increase.

Consent Calendar



HAMBLEN COUNTY DEPARTMENT OF EDUCATION FORMAL BID RECOMMENDATION FORM #14

[Signature]
Reviewed by

SCHOOL OR
CENTRAL OFFICE DEPT. BUSINESS DEPARTMENT

ITEM(S) BEING BID LIFE INSURANCE

QUANTITY _____

FUNDS: School Title I IDEA ARRA RTTT Bldg Prog Capital Other(specify) GENERAL

BID PROCEDURE: Any single item purchase or purchase of like items costing \$25,000 or more must be formally bid. Invitation to submit sealed bids must contain following information: school/Central Office department issuing bid; item being bid; statement that "faxes will be rejected"; address where bid specs may be picked up; date, time, location of bid opening; statement that "HCDOE reserves the right to accept or reject any and all bids." Bids must be published in local newspaper for 3 days (if item cost is \$50,000 or more, it must be advertised regionally). At least three bids should be obtained whenever possible. Items purchased from exclusive sources must be verified on vendor letterhead and signed by a vendor official. Bid opening must be no sooner than three weeks after first publication of ad.

	<u>VENDORS INVITED TO BID</u>	<u>DATE CONTACTED</u>	<u>BID RESPONSE</u>
1.	<u>USABLE</u>	<u>4/15/2026</u>	<u>\$ SEE ATTACHED</u>
2.	<u>AMERICAN FIDELITY</u>	<u>4/15/2026</u>	<u>\$ SEE ATTACHED</u>
3.	_____	_____	<u>\$ _____</u>
4.	_____	_____	<u>\$ _____</u>
5.	_____	_____	<u>\$ _____</u>
6.	_____	_____	<u>\$ _____</u>
7.	_____	_____	<u>\$ _____</u>
8.	_____	_____	<u>\$ _____</u>

IT IS HEREBY RECOMMENDED THAT THE ITEM(S) LISTED AT THE TOP OF THIS PAGE
BE PURCHASED FROM USABLE AT THE BID PRICE OF \$ SEE ATTACHED

Justification must be given below when low bid is not recommended
(previous service is not in itself sufficient justification):
AMERICAN FIDELITY DID NOT MEET SPECIFICATIONS

PRINCIPAL (SUPERVISOR) SIGNATURE *[Signature]* DATE 5-7-26

NOTE: When submitting this form to system accountant for approval, attach following items
--newspaper advertisement; dates --copy of all bid documents received
--invitation to bid; clean copy of specs --sign-in sheet of persons present at bid opening
--list of all persons invited to bid (use spreadsheet if necessary)
This form and above data to be maintained with supporting purchase documentation.

SL JL
ME CP

THREE-YEAR RATE BID SHEET		
Bid for Life Rates on Hamblen County Schools AND Hamblen County Government as a Single Group		
	Coverage	Rate
Basic Life (Schools)	\$40,000	<u>\$0.093</u> per \$1,000
AD & D (Schools)	\$40,000	<u>\$0.020</u> per \$1,000
Basic Life (Govt.)	\$20,000	<u>\$0.093</u> per \$1,000
AD & D (Govt.)	\$20,000	<u>\$0.020</u> per \$1,000
Dependent Life	\$10,000 on Spouse \$2,000 on Dependent Children	<u>\$1.760</u> per month
Retirees	\$10,000 to Age 70	<u>\$0.556</u> per \$1,000

COMPANY:
SIGNATURE:
DATE:

USAble Life
Melanie Edwards
May 4th, 2026

APPROVAL OF REGULAR CALENDAR ITEMS

Motion by Thomas Doty, seconded by Rodney Long to approve the Regular Calendar Items.

VOTE RESULTS

12 YES 0 NO 0 ABSTAIN 2 ABSENT

4.b. Approval of Regular Calendar Items

Majority of Full Membership

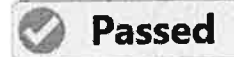

Joe Huntsman		ABSENT	Rodney Long	S	YES
Debbie Ahearn		YES	Jamie Carden		YES
Thomas Doty	M	YES	Stan Harville		YES
Wayne NeSmith		YES	Peggy Howell		YES
Mike Reed		YES	Bobby Haun		YES
Mike Richardson		YES	Tim Horner		ABSENT
Kyle Walker		YES	Edna Greene		YES

APPROVAL OF CONSENT CALENDAR

Motion by Thomas Doty, seconded by Stan Harville to approve the Consent Calendar.

VOTE RESULTS

12 YES | 0 NO | 0 ABSTAIN | 2 ABSENT

6.a. Consent Calendar

Majority of Full Membership

Passed

Joe Huntsman		ABSENT	Rodney Long		YES
Debbie Ahearn		YES	Jamie Carden		YES
Thomas Doty	M	YES	Stan Harville	S	YES
Wayne NeSmith		YES	Peggy Howell		YES
Mike Reed		YES	Bobby Haun		YES
Mike Richardson		YES	Tim Horner		ABSENT
Kyle Walker		YES	Edna Greene		YES

Hamblen County Legislative Body Regularly Meeting
May 21, 2026

OpenMeeting
BY POLYCOM

CONSENT CALENDAR**Thursday, May 21, 2026****Hamblen County Legislative Body**

Order #	Item	Placed From
1	Approval of the Previous Month's Minutes –April 23, 2026	Commission Chairman
2	Approval of Notaries	County Clerk Peggy Henderson
3	Jail/Justice Center Project Expenditures as of April 30, 2026	Justice Center/Public Safety Committee
4	Expenditure Reports – April 2026	Finance Committee
5	Revenue Summary Report- April 2026	Finance Committee
6	Monthly Checks- April 2026	Finance Committee
7	Planning Commission Building Permit Log – April 2026	Finance Committee
8	County Attorney Invoices –April 2026	Finance Committee
9	Trustee Report- April 1, 2026 – April 30, 2026	Finance Committee
10	Morristown Hamblen Emergency Medical Service Board of Directors Meeting Report March 25, 2026	Finance Committee
11	Approval of Education Pay Submissions Approval of Longevity Pay Submission	Personnel Committee

Thursday, May 21, 2026

SEI WASTE REQUEST FOR CLASS III LANDFILL

Motion by Thomas Doty, seconded by Stan Harville to approve SEI Waste request for Class III Landfill.

VOTE RESULTS 11 YES 1 NO 0 ABSTAIN 2 ABSENT

7.a. SEI Waste Request for Class III Landfill Majority of Full Membership

Passed

Joe Huntsman		ABSENT	Rodney Long		YES
Debbie Ahearn		YES	Jamie Carden		YES
Thomas Doty	M	YES	Stan Harville	S	YES
Wayne NeSmith		YES	Peggy Howell		YES
Mike Reed		YES	Bobby Haun		YES
Mike Richardson		YES	Tim Horner		ABSENT
Kyle Walker		YES	Edna Greene		NO

RESOLUTION 26-04

Motion by Rodney Long, seconded by Stan Harville to Resolution 26-04 – A resolution of the County Commission of Hamblen County, Tennessee approving an Economic Impact Plan for the Merchant’s Crossing Development Area.

VOTE RESULTS 10 YES 2 NO 0 ABSTAIN 2 ABSENT

8.a. Resolution 26-04

Majority of Full Membership

Economic Plan for Merchant's Crossing Development.

Passed

Joe Huntsman	ABSENT	Rodney Long	M	YES
Debbie Ahearn	YES	Jamie Carden		YES
Thomas Doty	YES	Stan Harville	S	YES
Wayne NeSmith	NO	Peggy Howell		NO
Mike Reed	YES	Bobby Haun		YES
Mike Richardson	YES	Tim Horner		ABSENT
Kyle Walker	YES	Edna Greene		YES



Hamblen County Legislative Body Regularly Meeting
May 21, 2026



RESOLUTION 26-04

**A RESOLUTION OF THE COUNTY COMMISSION OF HAMBLLEN COUNTY,
TENNESSEE APPROVING AN ECONOMIC IMPACT PLAN FOR THE
MERCHANT'S CROSSING DEVELOPMENT AREA**

WHEREAS, The Industrial Development Board of the City of Morristown, Tennessee (the "Board") has submitted to Hamblen County, Tennessee (the "County") an economic impact plan (the "Economic Impact Plan") regarding the development of an area generally located at 400 South Sugar Hollow Road, in Hamblen County, Tennessee (the "Plan Area"); and

WHEREAS, the development of the Plan Area is expected to include a retail shopping center with retail shops and restaurants (the "Project"); and

WHEREAS, the Economic Impact Plan would permit certain tax increment financing ("Tax Increment Financing") to be provided pursuant to Chapter 53, Title 7 of the Tennessee Code Annotated (the "Act"); and

WHEREAS, the Board has approved the submission to the County of the Economic Impact Plan at a meeting on May 11, 2026; and

WHEREAS, the proceeds of the Tax Increment Financing would be used to pay or finance eligible costs under the Act (the "TIF Eligible Costs") relating to the development of the Plan Area; and

WHEREAS, certain incremental property tax revenues (the "TIF Revenues") that result from the development of the Plan Area under the Economic Impact Plan will be allocated to the Board as provided in the Economic Impact Plan to be used to pay debt service of the Tax Increment Financing; and

WHEREAS, in accordance with the Economic Impact Plan, the Board would issue the Tax Increment Financing to a lender or lenders to finance the TIF Eligible Costs and would pledge the TIF Revenues to such lender or lenders to apply to the debt service on the Tax Increment Financing; and

WHEREAS, the Tax Increment Financing shall not represent or constitute a debt or pledge of the faith and credit or the taxing power of the Board, the City of Morristown, Tennessee or the County; and

WHEREAS, the Board of Directors of the Board has approved and submitted the Economic Impact Plan to the County Commission of Hamblen County, Tennessee for approval in accordance with Tenn. Code Ann. § 7-53-312; and

WHEREAS, the Board of Directors of the Board held a public hearing related to the Economic Impact Plan, and a summary of that public hearing has been provided to the County Commission of Hamblen County.

NOW, THEREFORE, BE IT RESOLVED by the County Commission of Hamblen County, Tennessee (the "County Commission"), that (i) the Economic Impact Plan, in the form attached hereto as Exhibit A, being in the interests of the citizens of Hamblen County, Tennessee, is hereby approved by the County Commission and (ii) the officers of the County are authorized to take all appropriate action to carry out the terms of the Economic Impact Plan.

Adopted and approved this 21ST day of May, 2026.

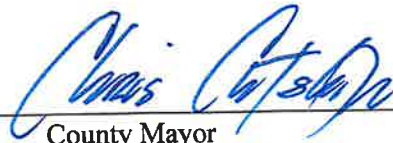

County Mayor

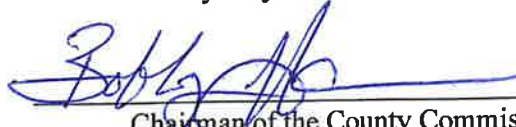

Chairman of the County Commission

ATTEST:



County Clerk

Exhibit A

Economic Impact Plan

(see attached)

50155868.1

**THE INDUSTRIAL DEVELOPMENT BOARD OF
THE CITY OF MORRISTOWN, TENNESSEE**

ECONOMIC IMPACT PLAN

FOR

MERCHANT'S CROSSING DEVELOPMENT AREA

I. Authority for Economic Impact Plan

Industrial development corporations ("IDBs") are authorized under Tenn. Code Ann. § 7-53-312 to prepare and submit to cities and counties an economic impact plan with respect to an area that includes a project within the meaning of Tenn. Code Ann. § 7-53-101 and such other properties that the IDB determines will be directly improved or benefited due to the undertaking of a project. Tennessee Code Annotated § 7-53-312 also authorizes cities and counties to allocate new incremental tax revenues, which arise from the area subject to the economic impact plan, to the IDB to promote economic development, to pay the cost of projects or to pay debt service on bonds or other obligations issued by the IDB to pay the costs of projects.

II. The Project

Merchant's Crossing, LLC, a Tennessee limited liability company, or an affiliate thereof (collectively, the "Developer"), has purchased and/ or contracted for the purchase of certain tracts of real property comprising approximately 31 acres in Hamblen County, Tennessee. The property, located at 400 South Bellwood Road, is bounded to the north by property owned by Akshar Lodging, LLC and Southern Railway, bounded to the east by South Bellwood Road, bounded to the south by Veterans Parkway and bounded to the west by Merchant's Greene Parkway. The property consists of four parcels which have been identified as tax parcels 048 059.00, 048 059.27, 048 059. 29 and 048 059.22 (collectively, the "Developer Parcel").

The Developer Parcel is ideally situated for commercial development. The Developer desires to undertake a significant multi-use development on the Developer Parcel. This development, which is expected to be undertaken in two phases, is expected to include a retail shopping center comprised of retail shops and restaurants. The development is collectively referred to herein as the "Project." Each component of the Project is expected to be an eligible project within the meaning of Tenn. Code Ann. § 7-53-101(15).

In order to make the Project financially feasible, the Developer has requested that Hamblen County, Tennessee (the "County") and the City of Morristown, Tennessee (the "City") approve, as part of this Economic Impact Plan, a plan for tax increment financing through The Industrial Development Board of the City of Morristown, Tennessee (the "Board") pursuant to Title 7, Chapter 53 of Tennessee Code Annotated to provide funds to pay a portion of the costs of the improvements that are needed to permit the construction and operation of the Project and the development of adjacent areas. The proceeds of the tax increment financing would be used to pay eligible costs, in accordance with the Tax Increment Act (as defined below), relating to the Project and the adjacent areas.

III. Boundaries of Plan Area

The Project is generally located northeast of the intersection of Veterans Parkway and Merchant's Greene Highway and across from the entrance to The Landing. The Project is located within the City and the County. The area that will be subject to this Economic Impact Plan (the "Plan Area") is shown on Exhibit A attached hereto. The Plan Area includes the Developer Parcel on which the Project will be located and certain nearby parcels that will be directly and materially benefitted by the Project and the traffic, utility and infrastructure improvements that will be completed in connection with the Project. A list of the parcels included in the Plan Area is also attached as part of Exhibit A. The Plan Area is hereby declared to be subject to this Economic Impact Plan, and the Project is hereby identified as the project that will be located within the Plan Area.

IV. Financial Assistance to Project

The Board will provide financial assistance to the Project by applying the proceeds of the tax increment financing described herein to pay or reimburse all or a portion of eligible costs that will be incurred by the Developer in connection with the development of the Project. These eligible costs include the costs of public infrastructure, which is defined under Tenn. Code Ann. § 9-23-102(16) as roads, streets, publicly-owned or privately-owned parking lots, facilities or garages, traffic signals, sidewalks or other public improvements that are available for public use, utility improvements and storm water and drainage improvements, whether or not located on public property or a publicly-dedicated easement.

Tenn. Code Ann. § 9-23-108 does not permit the application of incremental tax revenues to pay costs other than the costs of public infrastructure without first receiving a written determination from the Comptroller of the State of Tennessee (the "State") and the Commissioner of Economic and Community Development of the State that the use of tax increment revenues for such purposes is in the best interest of the State. The Developer shall not seek a written determination from the State without the prior approval of the Board by resolution of the Board. The Board will not apply the proceeds of the tax increment financing authorized hereunder to pay costs as to which such a written determination is required without first obtaining such written determination.

The Board will pay and/or reimburse the Developer for all or a portion of the eligible costs, including any costs approved by a written determination of the State, upon receipt of adequate documentation of such costs but only with the proceeds of the tax increment financing provided herein. In connection with the issuance of any tax increment financing, the Board and the Developer will enter into a development agreement specifying the scope and the cost of the improvements and fees to be paid and/or reimbursed. The proceeds of the tax increment financing are expected to be used to pay or reimburse infrastructure costs, including, but not limited to, the following:

1. Erection of two new traffic signals on Merchants Greene Blvd. Signals will not only facilitate traffic movement from the Project Area, but also the entire Plan Area including the heavily traveled Morristown Landing facility.

2. Relocation/improvement of South Bellwood Road by widening the road to three lanes and construction of both curb and gutter along with a sidewalk on the east side of the road. Elimination of current hazardous drop-offs along the shoulder of the road and sharp curves.
3. Implementation of water control devices accompanied by construction of detention ponds to manage water not only originating from the Project site, but also from as far away as Ingles.
4. Construction of a much-needed sanitary lift station. Installation of improved water lines.

V. Expected Benefits to City and County

As is well-documented from previous Morristown/Hamblen County TIFs, the benefits to the County and the City from such a planned development are both financially and culturally worthwhile. More specifically, the Project will benefit the City of Morristown, Hamblen County and surrounding area by providing jobs, providing substantial tax revenues to the local government, transforming agricultural property into a vibrant focal point and helping to cement Morristown as a destination for shopping and dining and providing improvements to the existing public infrastructure. Due to the growth in this area, a pump station is sorely needed to facilitate the proper handling of sewage and the installation of such is part of this Project. Furthermore, South Bellwood Road is narrow and winding, as part of this Project, this road will become three lanes and will be straightened.

The development of retail shopping centers and restaurants, such as the Project, will assist the City, the County and the Board in promoting economic development. When companies select locations for manufacturing, distribution and office facilities, a significant factor that is considered by site selection firms is the quality of life for the companies' employees in each community being considered as a possible location. By providing a wider array of retail shopping and dining choices, the Project will assist the Board with economic development recruiting and help expand the economic base of the City and County.

Both the City and the County are also expected to receive substantial additional taxes as a result of the development of the Plan Area. The ad valorem real property taxes for the Plan Area for the year 2025 were \$98,879 for the City and \$137,995 for the County, which are the base taxes relating to the Plan Area. Development of the Plan Area will increase the value of the real property within the Plan Area, leading to an increase in ad valorem real property taxes. Following the reappraisal of the Project after construction is completed, the annual real property taxes payable with respect to the entire Plan Area are expected to be approximately \$445,306 to the City and approximately \$619,323 to the County, for a total of \$1,064,629 in annual real property taxes. Of this total, the base taxes described above plus approximately \$275,758 in taxes that are allocable to paying debt service on the City's and the County's general obligation debt will be retained by the City and the County. These additional taxes for debt service will immediately benefit the City and the County. After the tax increment financing described below is paid, the remaining incremental property tax revenues will be payable to the City and the County, and the City and the County will benefit from those incremental taxes at that point and for years to come. The City and the County will also benefit from additional personal property taxes to the extent not allocated to

pay debt service on the tax increment financing described below.

Furthermore, the City and the County are expected to receive substantial additional sales tax revenues as a result of the development of the Project. All of the retailers and restaurants that are expected to locate in the Project are new to the City and the County, which should result in additional sales that may otherwise occur outside of the County and in new local sales tax revenues for both the City and the County. When the retail and restaurant operations in the Project are at full projected sales volumes, the annual local sales tax revenue generated is projected to be \$3,905,000.00.

Further research indicates that approximately 50% of these sales will be new sales to Hamblen County. This increase is based on new retail offerings and retaining current residents who are now shopping in Knoxville and surrounding areas and attracting those from Jefferson City, Dandridge and White Pine due to ease of access. The roadway improvements to SR 66 combined with traffic patterns on SR 160 are expected to aid in bringing shoppers to this area. Finally, these sales will also originate from additional discretionary spending given the variety of retailers and eateries as well as from the additional employment base.

Additionally, a significant number of jobs will be created within the County and the City. Initially, during the construction phase of the Project, the development will generate between 75-100 direct construction jobs. After completion of the Project, long-term employment opportunities will exist at the Project. The Developer estimates the total new jobs created from the Project to be approximately 480 after the Project is fully developed. The average wage including benefits for these jobs is expected to be approximately \$14.00 to \$20.00 per hour. Economic studies (e.g. University of Arkansas and San Jose University) validate multiplier effects for new wages within a community. Multipliers generally range between 1.0 and 3.0. Thus, personal income spending resulting from these new wages further substantiates a portion of the aforementioned anticipated new sales.

VI. Distribution of Property Taxes and Tax Increment Financing

a. Distribution of Taxes. Property taxes, including personal property taxes, imposed on the property located within the Plan Area shall be allocated and distributed as provided in this subsection. The taxes assessed by the County and the City on the real and personal property within the Plan Area will be divided and distributed as follows in accordance with Tenn. Code Ann. § 7-53-312(c) and Title 9, Chapter 23 of the Tennessee Code Annotated, being the Uniformity in Tax Increment Financing Act of 2012 (the "Tax Increment Act"):

i. The portion of the real and personal property taxes payable with respect to the Plan Area equal to the year prior to the date of approval of this Economic Impact Plan (the "Base Tax Amount") shall be allocated to and, as collected, paid to the County and the City as all other taxes levied by the County and the City on all other properties; provided, however, that in any year in which the taxes on the property within the Plan Area are less than the Base Tax Amount, there shall be allocated and paid to the County and the City only the taxes actually imposed.

ii. 75% of the excess of real and personal property taxes over the Base Tax Amount (the "TIF Revenues") shall be allocated and, as collected, paid into a separate fund of the Board, created to hold such payments until the tax proceeds in the fund are to be applied to pay debt service on the obligations expected to be issued by the Board that are described to pay eligible costs, as described above.

This allocation is subject to the provisions of Tenn. Code Ann. §7-53-312(j) and the Tax Increment Act, which requires that taxes levied upon property within the Plan Area for the payment of debt service of the County and the City shall not be allocated to the Board. Furthermore, in accordance with the Board's TIF Policies, for each year that TIF Revenues are allocated to the Board, the Board is authorized to retain an annual Administrative Fee in the amount of \$1,000.00 (the "Annual Administrative Fee"); provided, however, that in accordance with Tenn. Code Ann. § 9-23-105, the Annual Administrative Fee in any year shall not exceed 5% of the TIF Revenues for such year. Attached hereto as Exhibit B are the estimated TIF Revenues following the completion of the Project.

The Developer expects to resubdivide the Developer Parcel into multiple parcels in order to facilitate the phased development of the Plan Area. The base taxes with respect to the Developer Parcel shall be allocated to each parcel created by the Developer on a pro-rated basis using the acreage of each subdivided parcel as a percentage of the total acreage of the original Developer Parcel. If any other tax parcels in the Plan Area are subdivided or redesignated, the base taxes shall be allocated in a similar manner.

The Board is authorized to make all calculations of TIF Revenues on the basis of each parcel within the Plan Area instead of on an aggregate basis as permitted by the Tax Increment Act. If the Board opts to have such calculations made based upon each parcel, the Board shall give notice to the City and the County that such methodology will be used prior to the first allocation date of any TIF Revenues.

As permitted by the Tax Increment Act, the Board is hereby authorized to separately group one or more parcels with the Plan Area for purposes of calculating and allocating the TIF Revenues, and in such case, the allocation of TIF Revenues shall be calculated and made based upon each such parcel or group of parcels, and not the entire Plan Area. The Board is specifically authorized to undertake such grouping of parcels at any time that this Plan is effective as of the beginning of any year (but not later than the fifth full year commencing after the execution of the initial development agreement with the Developer, provided that the Board may extend such grouping deadline by not to exceed an additional five years without the further approval of the City and County), and the Board may reserve the right in any development agreement with the Developer to regroup one or more parcels for purposes of making the calculations of TIF Revenues hereunder. The Board shall give notice of any such grouping of parcels to the City and the County.

The Board is also authorized to designate that the allocation of TIF Revenues from any parcel or group of parcels shall begin in different years in order to match TIF Revenues with the application of TIF Revenues for the purposes provided herein, subject to the maximum allocation period as to any parcel provided below, provided that allocation of TIF Revenues as to any parcel in the Plan Area must commence no later than the fifth full year after the execution of the initial

development agreement with the Developer, provided that the Board may extend such commencement deadline by not to exceed an additional five years without the further approval of the City and County. The Board shall give notice of any such designation to the City and the County.

Allocations of TIF Revenues collected by the City and the County that are not delinquent shall be made as to each tax year no later than sixty (60) days after the date such taxes would be delinquent in payment, allocations of TIF Revenues relating to delinquent taxes shall be made not later than sixty (60) days from when such TIF Revenues are collected by the City or the County.

b. TIF Obligations. In order to pay for or reimburse eligible costs, as described above, needed for the Project, the Board intends to use the incremental tax revenues that it would receive as a result of the adoption of the Economic Impact Plan to pay debt service on obligations incurred to finance such costs. This tax increment financing will be structured as follows:

i. The Board will borrow not to exceed \$5,500,000 (not including refinancings) through the issuance and sale of notes, bonds or other obligations of the Board in multiple series from time to time as each component of the Project is undertaken. The Board shall pledge any and all TIF Revenues allocated to the Board pursuant to this Economic Impact Plan to the payment of such notes, bonds or other obligations, including, without limitation, principal and interest thereon. In no event will the obligations issued by the Board be considered a debt or obligation of the County or the City in any manner whatsoever, and the source of the funds to satisfy the Board's payment obligations thereunder shall be limited solely to the TIF Revenues and shall otherwise be non-recourse to the Board. As each series of the notes, bonds or other obligations are issued, the Developer shall apply to the Board, under the applicable policies of the Board, for the issuance of the applicable series of notes, bonds or other obligations and demonstrate, at such time, that the TIF Revenues to be realized from such component of the Project will be sufficient to pay debt service on the notes, bonds or other obligations requested to be issued by the Developer.

ii. The proceeds of the notes, bonds or obligations shall be used to pay eligible costs relating to the Project as described above together with expenses of the Board in connection with the Project and the tax increment financing and capitalized interest on the notes, bonds or other obligations for a maximum period of two (2) years from the date of completion of the Project.

Any development agreement with the Developer shall provide for such portion of the tax increment revenues as the Board, the County and/or the City require under any applicable policies to be withheld for administrative expenses to be so withheld, which amount shall not exceed the amount permitted by the Tax Increment Act, and for such withheld amounts to be applied as required by such policies.

c. Time Period. Taxes on the real and personal property within the Plan Area will be divided and distributed as provided in this Plan for a period, as to each parcel in the Plan Area, not in excess of twenty (20) tax years as to any parcel, but, in any event, such allocations shall cease when there are not eligible costs, including debt service, to be paid from the TIF Revenues.

d. Finding of Economic Benefit. The Board, the County and the City, by the adoption of this Economic Impact Plan, find that the use of the TIF Revenues as described herein, is in furtherance of promoting economic development in the City and County and that costs to be financed as described herein are costs of the Project.

VII. Approval Process

Pursuant to Tenn. Code Ann. § 7-53-312, the process for the approval of this Economic Impact Plan is as follows:

a. The Board holds a public hearing relating to the proposed Economic Impact Plan after publishing notice of such hearing in a newspaper of general circulation in the County and the City at least two (2) weeks prior to the date of the public hearing. The notice must include the time, place and purpose of the hearing as well as notice of how a map of the subject area may be viewed by the public. Following such public hearing, the Board may submit the Economic Impact Plan to the County and the City for their approval.

b. The governing bodies of the County and the City must approve the Economic Impact Plan. The Economic Impact Plan may be approved by resolution of the County Commission or the City Council, whether or not the local charter provisions of the governing bodies provide otherwise. If either the County or the City make any changes to this Economic Impact Plan in connection with their approval hereof, such changes must be approved by the Board and the governing body of the City or County that did not make such change for the Plan to be effective.

c. Once the Economic Impact Plan has been approved by the governing bodies of the County and the City, the Plan and related documentation shall be filed with the local taxing officials and the Comptroller of the State as required by the Tax Increment Act and annual statements of incremental tax revenues allocated to the Board shall be filed with the State Board of Equalization as required by the Tax Increment Act. The Board will also comply with all other procedural requirements of the Tax Increment Act and other applicable laws.

Exhibit A
(to Economic Impact Plan)

Parcels comprising the Plan Area

<u>Tax ID Number*</u>
048 059.00
048 059.22
048 059.27
048 059.29
040 083.01
040 083.00
048 059.23
040 084.01
048 059.12
048 059.13
048 059.13 001
048 059.17
048 E A 004.00
048 059.10
048 059.25
048 058.02
048 058.01
048 057.00
048 056.00
048 059.21
048 059.20
048 059.24
048 059.07
048 059.26
048 059.19
048 059.16
048 059.18
048 058.00
048 059.15

*Tax parcel numbers as of May 11, 2026

Map of Plan Area



May 21, 2026

[Return to Regular Calendar](#)

Exhibit B
(to Economic Impact Plan)

Assumed Development Excluding City And County Debt Portions

<u>Year</u>	<u>Current Taxes</u>	<u>Forecasted Real Estate ** Taxes (City)</u>	<u>Forecasted Real Estate ** Taxes (County)</u>	<u>Forecasted Personal Property ** Taxes (City)</u>	<u>Forecasted Personal Property ** Taxes (County)</u>	<u>Allocable Increment Available To IDB</u>
2028	\$18,243	\$219,458	\$369,025	\$31,516	\$52,995	\$654,751
2029	\$18,243	\$219,458	\$369,025	22,996	38,669	631,906
2030	\$18,243	\$219,458	\$369,025	18,079	30,401	618,721
2031	\$18,243	\$219,458	\$369,025	11,804	19,849	601,893
2032	\$18,243	\$219,458	\$369,025	8,971	15,085	594,296
2033	\$18,243	\$219,458	\$369,025	5,902	9,925	586,067
2034	\$18,243	\$219,458	\$369,025	4,722	7,940	582,901
2035	\$18,243	\$219,458	\$369,025	4,722	7,940	582,902

50102278.3

Finance
5. a.

Morristown

P.O. Box 9 • 825 West First North St. • Morristown, TN 37815 • Ph. 423-586-6382

May 11, 2026

Mayor Chris Cutshaw
Hamblen County
511 W. Second North St.
Morristown, TN 37814

Dear Chris:

At a special called meeting of the Industrial Development Board of the City of Morristown on April 16, 2026, the Board reviewed and accepted an application for tax increment financing for the Merchants Crossing development project located on Merchants Greene Blvd. and requested that an Economic Impact Plan be produced for consideration. During a subsequent meeting on May 11, 2026, a Public Hearing was held and then the board considered and approved of the Economic Impact Plan for the Merchants Crossing project.

Attached is the Resolution and Economic Impact Plan for the project for the County Commission to review. The Board requests that this item be placed on the agenda for the May 21st meeting for Commission members to consider. If approved, the plan will move forward and the Industrial Board will prepare legal documents for the plan to be put into place.

Please feel free to contact me with any questions.

Sincerely,

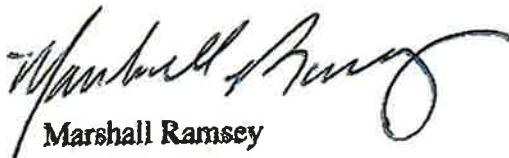

Marshall Ramsey
Secretary

MR/jb

MORRISTOWN-HAMBLEN HUMANE SOCIETY AGREEMENT

Motion by Rodney Long, seconded by Debbie A’Hearn to approve the Agreement between Hamblen County, Tennessee and Morristown-Hamblen Humane Society.

VOTE RESULTS 11 YES 1 NO 0 ABSTAIN 2 ABSENT

8.b. Hamblen County, TN and Morristown-Hamblen Humane Society Agreement Majority of Full Membership

Passed

Joe Huntsman		ABSENT	Rodney Long	M	YES
Debbie Ahearn	S	YES	Jamie Carden		YES
Thomas Doty		YES	Stan Harville		YES
Wayne NeSmith		YES	Peggy Howell		YES
Mike Reed		YES	Bobby Haun		YES
Mike Richardson		YES	Tim Horner		ABSENT
Kyle Walker		YES	Edna Greene		NO

AGREEMENT

THIS AGREEMENT is made this 1st day of July, 2026 by and between HAMBLEN COUNTY, TENNESSEE, a political subdivision of the State of Tennessee ("COUNTY"); and MORRISTOWN-HAMBLÉN HUMANE SOCIETY, a non-profit agency created by Charter on July 19, 1972 ("MHHS"), which is operated by a board of directors ("BOARD").

WHEREAS

1. The COUNTY has created an Animal Control division to County Government for the purpose of providing animal control services for the citizens of the County;
2. The COUNTY has contracted with the City of Morristown ("CITY") to provide animal control services for residents within the Morristown corporate limits;
3. The agreement between the CITY and COUNTY also includes the COUNTY providing animal shelter services to City residents through this agreement with MHHS;
4. The COUNTY wishes to contract with the Morristown-Hamblen Humane Society to provide animal shelter services for the COUNTY'S Animal Control Department and its obligations to the CITY under the terms of the animal care services agreement between the COUNTY and CITY;

TERMS AND CONDITIONS

IT IS THEREFORE AGREED BY AND AMONG THE PARTIES THAT DURING THE TERM OF THIS CONTRACT, INCLUDING EXTENSION AND RENEWALS:

- a) **Animal Shelter Services.** The MHHS shall provide animal shelter services that will include, but are not limited to, a) housing and care for all stray dogs and cats from citizens of Hamblen County and the City of Morristown; b) housing and care for all dogs and cats confiscated and/or impounded by animal control officers (ACO); c) animal adoption services; d) animal rescue programs; e) end of life services for very sick, older, or injured animals with a sliding-scale fee structure; and f) animal owner-surrender services as space permits with a sliding-scale fee structure to help cover the costs for caring for the animals.
- b) **Education Services.** MHHS will partner with the Animal Control Department to provide public education programs to promote spay/neuter issues, and to answer questions and/or concerns. It will also help educate the public about how to resolve animal behavior issues that are causing problems for pet owners and/or their families.
- c) **Board.** The BOARD shall consist of thirteen (13) members, eight of whom shall be selected by MHHS; the City Mayor, or his designee; the County Mayor, or his designee; a Hamblen County citizen who may reside in the city, appointed by the City Mayor; a Hamblen County citizen who may reside in the city, appointed by the County Mayor; and a citizen appointed by the City Council who may not be an employee or officer of the

AGREEMENT

City or County. If there should be a conflict between the MHHS by-laws and this provision, MHHS shall amend its by-laws to conform to this agreement. (Possible changes to Board membership may be negotiated.)

- e) **Tax exempt status.** MHHS shall maintain a 501(c)(3) tax exempt status with the Internal Revenue Service.
- f) **Budget and Financial Reports.** MHHS shall submit to the County Finance Department a proposed budget and appropriations request for the subsequent fiscal year by March 15th. MHHS shall submit monthly financial reports to the County Mayors' office by the 15th day of each month.
- g) **Accounting reports.** MHHS shall conduct a separate accounting report of funds received for fines, adoption fees, rescue reimbursements/operations, building donations, and all other funds.
- h) **Audit.** MHHS shall have a financial audit completed for each fiscal year and shall submit said audit report to the Animal Control Director and the County Mayor's offices.
- i) **Insurance.** MHHS shall obtain and maintain all appropriate insurance policies., including, but not limited to, workers' compensation insurance, comprehensive liability insurance and officers and directors insurance with coverage's and companies which are A-rated or better. The County will carry workers' compensation and all appropriate liability insurance for the ACO's.
- j) **Termination.** Any party may terminate this contract **for cause** by providing written notice of the cause alleged to entitle the notifying party to terminate the contract. If the alleged cause is not corrected within forty-five (45) days of notification, the notifying party may declare default and terminate the contract on a date certain which shall not be less than thirty (30) days. During the notice period, MHHS agrees to continue providing care for the animals until the notice period expires. Thereafter, it shall be the responsibility of the CITY and COUNTY to care for the animals and comply with their obligations concerning animal control. Once the notice period expires, MHHS agrees to give the CITY and COUNTY access to the premises to care for the animals until the CITY and COUNTY can arrange for another location to provide animal care. In the event of termination, all requirements of MHHS to report to the CITY and/or COUNTY, based upon tis Contract, shall terminate.
- k) **Operating Funds.** IN the event of termination or non-renewal of this agreement, the MHHS will not be responsible for refunding any operating funds to the COUNTY.
- l) **Debts of MHHS.** In the event of a termination or non-renewal of this agreement, the COUNTY and the CITY shall not be responsible for any outstanding debts, including

AGREEMENT

loans, unpaid payroll or payroll taxes, and accounts payable accumulated through the effective date of termination or end of the contract term.

- m) **Fees.** All of the fees paid by animal owners associated with impoundment of their animals shall be collected by MHHS and become the sole property of MHHS.
- n) **Indemnification.** MHHS shall indemnify and hold the COUNTY harmless from any claims, losses or liability which may arise from the MHHS's operations or act of its employees, officers and directors. (MHHS will not be held accountable for any animal control complaints in which the CITY OR COUNTY officers refuse to enforce when recommended by animal control humane officers.)
- o) **Term.** Unless earlier terminated pursuant to this agreement, the term shall commence as of July 1, 2026, ending at midnight on June 30, 2027. This agreement will automatically renew for a period of one (1) year on July 1, 2027, unless any party notifies the others in writing no less than 60 days prior to the end of term that it does not wish to renew the agreement.
- p) **Funding.** During the term hereof, funding shall be in monthly installments of \$25,000. Payments shall be made on or before the 15th day of the month.
- q) **Independent Contractors.** In performing their duties and exercising their rights hereunder, the parties shall be deemed to be acting as independent contractors.
- r) **Binding parties.** This agreement shall be binding on the parties hereto, their successors and assigns.

EXECUTED on the day and date first above appearing.

HAMBLEN COUNTY, TENNESSEE ("COUNTY")

BY: _____

Chris Cutshaw

MORRISTOWN-HAMBLEN HUMANE SOCIETY ("MHHS")

BY: _____

BOARD PRESIDENT

May 21, 2026

[Return to Regular Calendar](#)

THIRD JUDICIAL RECOVERY SUPPORT SERVICES, INC.

Motion by Rodney Long, seconded by Thomas Doty to approve the request from the Third Judicial Recovery Support Services, Inc to distribute balance of \$10,800.76 towards Operating Housing Expenses.

VOTE RESULTS

11 YES 1 NO 0 ABSTAIN 2 ABSENT

8.c. Request from 3rd Judicial Recovery Support Services, Inc.

Majority of Full Membership

Passed

Joe Huntsman	ABSENT	Rodney Long	M	YES
Debbie Ahearn	YES	Jamie Carden		YES
Thomas Doty	S YES	Stan Harville		YES
Wayne NeSmith	NO	Peggy Howell		YES
Mike Reed	YES	Bobby Haun		YES
Mike Richardson	YES	Tim Horner		ABSENT
Kyle Walker	YES	Edna Greene		YES

Hamblen County Legislative Body Regularly Meeting
May 21, 2026

OpenMeeting

M



**1125 W 1st N Ste B
Morristown, TN, 37814**

May 1, 2026

Dear Hamblen County Commission,

The 3rd Judicial District Recovery Support Services, Inc. (TJRSS) in February 2023 was appropriated from Hamblen County \$500,000.00 in funds from the Endo Pharmaceutical Opioid Settlement to purchase safe, stable, long-term, sober housing for Recovery Court participants. The Hamblen County Commission voted a majority in favor of this appropriation of funds in September 2022.

The monies were used to purchase and renovate 315 and 321 N. High St.

There is currently a **\$10,800.76** balance left from the \$500,000 appropriation from the purchase and repairs. TJRSS would like to request consideration for this balance to be distributed to the non-profit to apply towards operating housing expenses such as insurance, utilities, etc.

Thank you for your faithful partnership aiding those in recovery.

Penny Knight, President

Don Baird, Vice-President

Sarah Gulley, Treasurer

Laura Moore, Secretary

Chad Mullins, Board Member

Lee Shepard, Board Member

Gwen Thomas, Board Member

Landon Pyle, Board Member

Scott Knight, Board Member

May 21, 2026

[Return to Regular Calendar](#)

FY26 HOMELAND SECURITY GRANT APPLICATION

Motion by Rodney Long, seconded by Thomas Doty to approve the FY26 Homeland Security Grant Application from EMA.

VOTE RESULTS

12 YES | 0 NO | 0 ABSTAIN | 2 ABSENT

8.d. FY26 Homeland Security Grant Application

Majority of Full Membership

Passed

Joe Huntsman		ABSENT	Rodney Long	M	YES
Debbie Ahearn		YES	Jamie Carden		YES
Thomas Doty	S	YES	Stan Harville		YES
Wayne NeSmith		YES	Peggy Howell		YES
Mike Reed		YES	Bobby Haun		YES
Mike Richardson		YES	Tim Horner		ABSENT
Kyle Walker		YES	Edna Greene		YES



Hamblen County Legislative Body Regularly Meeting
May 21, 2026

May 21, 2026 11:00 AM
OpenMeeting



Morrystown-Hamblen Emergency Management Agency
Hamblen County Courthouse
511 West Second North Street
Morrystown, Tennessee 37814
(423) 581-6225
ricky.purkey@co.hamblen.tn.us

MEMORANDUM

TO: Amanda Hale, Finance Director
FROM: Ricky Purkey
DATE: 5 May 2026
RE: FY26 Homeland Security Grant
CC: All Commissioners; Trish Bowman, County Mayors Office

The EMA office has received the request for application for the contract for the FY26 Homeland Security Grant through the District II Office of Homeland Security. This grant, like those in the past, is a federally funded, 100% grant with no match required. My office is applying for this grant in the amount of \$24,000.

In accordance with the grant contract, my office intends to comply with the terms and limitations of the Initial Strategy Implementation Plan (ISIP) and the National & State Priorities.

The scope of this grant will provide necessary equipment / upgrades for the various Emergency Departments which is state mandated.

All agencies / departments that will be receiving equipment purchased from this grant have submitted documentation stating their compliance with the National Incident Management System (NIMS), which is a requirement for receipt of homeland security grant funding.

I respectfully request that approval be given to fill out the application for the FY26 Grant.

I will contact Administrative Assistant Trish Bowman to have this item placed on the May Commission agenda.

As always, I will be available to answer any questions that you or the other Commissioners may have.

Thank you.

May 21, 2026

[Return to Regular Calendar](#)

RESOLUTION 26-05

Motion by Rodney Lond, seconded by Kyle Walker to approve Resolution 26-05 - a resolution to utilize the Tennessee Certified Recovery Court Program Award in FY 2026-2027.

VOTE RESULTS 11 YES 1 NO 0 ABSTAIN 2 ABSENT

8.e. Resolution 26-05 Majority of Full Membership

Tennessee Certified Recovery Court Program Award in FY 2026-2027. **Passed**

Joe Huntsman		ABSENT	Rodney Long	M	YES
Debbie Ahearn		YES	Jamie Carden		YES
Thomas Doty		YES	Stan Harville		YES
Wayne NeSmith		NO	Peggy Howell		YES
Mike Reed		YES	Bobby Haun		YES
Mike Richardson		YES	Tim Horner		ABSENT
Kyle Walker	s	YES	Edna Greene		YES

RESOLUTION 26 - 05

RESOLUTION TO UTILIZE THE TENNESSEE CERTIFIED RECOVERY COURT PROGRAM AWARD IN FY2026-2027

WHEREAS, The State of Tennessee, Department of Mental Health and Substance Abuse Services support local recovery court programs in cities and counties across the state of Tennessee to help those with substance and mental health issues in the criminal justice system;

WHEREAS, The State of Tennessee, Department of Mental Health and Substance Abuse Services recognizes that Hamblen County has a Certified Recovery Court, and has offered a grant award to Hamblen County continuously since 2012;

WHEREAS, The grant award between The State of Tennessee, Department of Mental Health and Substance Abuse Services and Hamblen County requires no match, but is solely offered to partner and support the 3rd Judicial District Hamblen County Recovery Court;

WHEREAS, The county legislative body of Hamblen County has determined the best interests of Hamblen County to utilize the annual award for FY2026-2027 in the amount of \$103,000.00 with the State of Tennessee, Department of Mental Health and Substance Abuse Services;

NOW, THEREFORE, BE IT RESOLVED, that the Hamblen County legislative body does hereby approve that the grant funds from the State of Tennessee, Department of Mental Health and Substance Abuse Services be used to support the Third Judicial District Hamblen County Recovery Court:

Approved this 21st day of May, 2026.

APPROVED:

Bobby Haun, Chairman HCLB

APPROVED:

Chris Cutshaw, County Mayor

ATTEST:

Peggy Henderson, County Clerk

RESOLUTION 26-06

Motion by Rodney Long, seconded by Thomas Doty to approve Resolution 26-06 – a resolution to utilize the Tennessee Certified Mental Health Recovery Court Program Award in FY 2026-2027.

VOTE RESULTS 12 YES 0 NO 0 ABSTAIN 2 ABSENT

8.f. Resolution 26-06

Majority of Full Membership

Tennessee Certified Mental Health Recovery Court Program Award in FY 2026-2027.

 **Passed**

Joe Huntsman		ABSENT	Rodney Long	M	YES
Debbie Ahearn		YES	Jamie Carden		YES
Thomas Doty	S	YES	Stan Harville		YES
Wayne NeSmith		YES	Peggy Howell		YES
Mike Reed		YES	Bobby Haun		YES
Mike Richardson		YES	Tim Horner		ABSENT
Kyle Walker		YES	Edna Greene		YES



Hamblen County Legislative Body Regularly Meeting
May 21, 2026

May 21, 2026 11:58 PM
OpenMeeting

RESOLUTION 26 - 06

RESOLUTION TO UTILIZE THE TENNESSEE CERTIFIED MENTAL HEALTH RECOVERY COURT PROGRAM AWARD IN FY2026-2027

WHEREAS, The State of Tennessee, Department of Mental Health and Substance Abuse Services support local mental health recovery court programs in cities and counties across the state of Tennessee to help those with substance and mental health issues in the criminal justice system;

WHEREAS, The State of Tennessee, Department of Mental Health and Substance Abuse Services recognizes that Hamblen County has a Certified Mental Health Recovery Court, and has offered a grant award to Hamblen County since 2023;

WHEREAS, The grant award between The State of Tennessee, Department of Mental Health and Substance Abuse Services and Hamblen County requires no match, but is solely offered to partner and support the 3rd Judicial District Hamblen County Mental Health Recovery Court and Hamblen County General Sessions Court to provide expanded mental health services;

WHEREAS, The county legislative body of Hamblen County has determined the best interests of Hamblen County to utilize the annual award for FY2026-2027 in the amount of \$180,000.00 with the State of Tennessee, Department of Mental Health and Substance Abuse Services;

NOW, THEREFORE, BE IT RESOLVED, that the Hamblen County legislative body does hereby approve that the grant funds from the State of Tennessee, Department of Mental Health and Substance Abuse Services be used to support the Third Judicial District Hamblen County Mental Health Recovery Court :

Approved this 21st day of May, 2026.

APPROVED:

Bobby Haun, Chairman HCLB

APPROVED:

Chris Cutshaw, County Mayor

ATTEST:

Peggy Henderson, County Clerk

HOLSTON CONNECT LITIGATION SETTLEMENT

Motion by Rodney Long, seconded by Stan Harville to approve the Holston Connect Litigation Settlement of \$60,000.

VOTE RESULTS

12 YES | 0 NO | 0 ABSTAIN | 2 ABSENT

8.g. Holston Connect Litigation Settlement

Majority of Full Membership

Passed

Joe Huntsman	ABSENT	Rodney Long	M	YES
Debbie Ahearn	YES	Jamie Carden		YES
Thomas Doty	YES	Stan Harville	S	YES
Wayne NeSmith	YES	Peggy Howell		YES
Mike Reed	YES	Bobby Haun		YES
Mike Richardson	YES	Tim Horner		ABSENT
Kyle Walker	YES	Edna Greene		YES

Hamblen County Legislative Body Regularly Meeting
May 21, 2026

OpenMeeting

SETTLEMENT AGREEMENT AND RELEASE OF CLAIMS

This Settlement Agreement and Release of Claims (the "Agreement") is made and entered into by and between **HolstonConnect, LLC** ("HolstonConnect") and **Hamblen County** ("Hamblen") (collectively, the "Parties") as of the later of (a) the date on which this Agreement has been executed by both Parties and (b) the date on which HolstonConnect receives the materials described in Section 2(c) below (the "Effective Date").

RECITALS

WHEREAS, the Town of Bulls Gap filed a Petition for Declaratory Judgment against HolstonConnect, LLC, Hamblen County, Hawkins County, the City of Morristown, the Town of Rogersville, the Town of Surgoinsville, and the City of Church Hill (collectively, the "Co-Defendants"), pending in the Chancery Court for Hawkins County, Tennessee, Case No. 2024-CH-84 (the "Action");

WHEREAS, Bulls Gap (and those joining) sought, among other things, a declaration that HolstonConnect is a "video service provider" as defined by the Competitive Cable and Video Services Act, Tenn. Code Ann. § 7-59-301, *et seq.*, and sought from HolstonConnect payment of alleged franchise fees owed in connection with HolstonConnect's provision of video services under its HolstonTV service;

WHEREAS, HolstonConnect denies any wrongdoing or liability to Hamblen;

WHEREAS, the Parties, together with other parties to the Action, participated in a mediation and desire to compromise and settle Hamblen's claims against HolstonConnect and any related disputes arising from the Action; and

WHEREAS, the Parties desire to set forth the full terms of their settlement in this Agreement.

NOW, THEREFORE, in consideration of the foregoing and the mutual covenants, representations, warranties, releases, and agreements contained herein, and for other good and valuable consideration, the receipt and sufficiency of which are acknowledged, the Parties agree as follows:

1. Incorporation. The foregoing recitals are incorporated herein by reference as if fully set forth herein.

2. Governing Body Approval; Effective Date; Conditions Precedent. Hamblen represents and warrants that its Board of County Commissioners has duly authorized, approved, and ratified the execution, delivery, and performance of this Agreement and the settlement contemplated hereby, that such approval was taken at a duly called meeting in accordance with applicable law, and that no further action, approval, appropriation, or authorization is required for this Agreement to constitute the valid and binding obligation of Hamblen. As a condition precedent to the Effective Date and to HolstonConnect's obligation to make the Settlement Payment, Hamblen shall deliver to HolstonConnect:

(a) a fully executed original or counterpart of this Agreement;

(b) a Stipulation of Dismissal with Prejudice and a proposed Order of Dismissal with Prejudice, each in form reasonably acceptable to HolstonConnect, executed by counsel for Hamblen and suitable for filing in the Action; and

(c) a certified copy of the minutes, resolution, or other official action of the Board of County Commissioners evidencing approval of this Agreement or the settlement contemplated hereby and authorizing the County Mayor executing this Agreement on behalf of Hamblen. The Effective Date shall not occur unless and until HolstonConnect has received all items described in this Section 2.

3. Settlement Payment. Subject to the occurrence of the Effective Date, HolstonConnect shall pay to Hamblen the total sum of Sixty Thousand Dollars (\$60,000.00) (the "Settlement Payment") within fourteen (14) days after the Effective Date. The Settlement Payment shall be paid in good and available funds pursuant to written payment instructions provided separately by Hamblen's counsel. The Settlement Payment shall be deemed made when received by Hamblen in good and available funds.

4. Dismissal of Claims and Disposition of Action. Within three (3) business days after Hamblen's receipt of the Settlement Payment, Hamblen shall cause the Stipulation of Dismissal with Prejudice to be filed in the Action and shall take all actions reasonably necessary to dismiss with prejudice any and all claims asserted by Hamblen against HolstonConnect in the Action. Hamblen represents that, except for the Action, there are no pending lawsuits, charges, administrative proceedings, or other claims by Hamblen against HolstonConnect in any court, tribunal, or agency arising from or relating to the subject matter of the Action.

5. Attorneys' Fees, Mediator's Fees, and Court Costs. Each Party shall bear its own attorneys' fees and expenses incurred in connection with the matters addressed in this Agreement, including the Action, settlement negotiations, and preparation of this Agreement. HolstonConnect shall pay all mediator's costs and fees attributable to the Action, as well as any court costs.

6. No Admission of Liability. This Agreement is a compromise of disputed claims. HolstonConnect denies and continues to deny all wrongdoing, liability, and damages alleged or asserted by Hamblen. Neither this Agreement nor any payment or undertaking made pursuant to it shall constitute or be construed as an admission by HolstonConnect of any liability, fault, or wrongdoing.

7. Release by Hamblen. In consideration of the promises and payment described herein, Hamblen, on behalf of itself and its present and former officials, officers, employees, agents, representatives, attorneys, successors, and assigns, fully and forever releases and discharges HolstonConnect and its parent entities, subsidiaries, affiliates, divisions, members, managers, officers, directors, employees, agents, representatives, attorneys, insurers, reinsurers, successors, and assigns (collectively, the "Released Parties") from any and all claims, demands, actions, causes of action, suits, liabilities, losses, damages, costs, expenses, and obligations of every kind, whether known or unknown, suspected or unsuspected, fixed or contingent, in law or in equity, that Hamblen ever had, now has, or may claim to have as of the date Hamblen executes this Agreement,

arising out of or relating in any way to the Action or to the facts, transactions, occurrences, communications, dealings, contracts, attempted contracts, or other matters between Hamblen and any of the Released Parties occurring on or before the date Hamblen executes this Agreement (the "Released Claims"). Hamblen understands and agrees that the Released Claims include claims based on facts that may later be discovered to be different from or in addition to those now known or believed to exist. Notwithstanding the foregoing, the Released Claims do not include any claim to enforce this Agreement or any claim arising from breach of this Agreement or fraud or intentional misrepresentation in connection with the authority, approval, execution, or performance of this Agreement.

8. No Assignment. Each Party represents and warrants that it has not assigned, transferred, or purported to assign or transfer any claim released by this Agreement.

9. Non-Disparagement; Required Disclosures. The Parties agree that they shall not knowingly make or publish false and disparaging statements about the other concerning the matters resolved by this Agreement. This Section does not prohibit truthful statements required by law; statements made in response to subpoenas, court orders, public records requests, or audit or regulatory inquiries; statements made in public meetings or public records in the ordinary course of county governance; or statements by counsel in connection with the Action or enforcement of this Agreement.

10. Further Assurances. The Parties shall execute and deliver such further documents and take such further actions as may be reasonably necessary to effectuate the intent and purposes of this Agreement.

11. Amendment. This Agreement may be amended only by a written instrument expressly referring to this Agreement and executed by authorized representatives of both Parties.

12. Default; Enforcement; Fees. A Party's failure to perform any material obligation under this Agreement shall constitute a default. In any action or proceeding to enforce this Agreement, the prevailing party shall be entitled to recover its reasonable attorneys' fees, expenses, and costs incurred in connection with such enforcement action, in addition to any other relief awarded.

13. Voluntary Agreement; Counsel. Each Party acknowledges that it has read this Agreement in its entirety, understands its terms, has had the opportunity to consult with legal counsel of its choosing, and enters into this Agreement voluntarily and without reliance on any promise or representation not expressly set forth herein.

14. Governing Law and Venue. This Agreement and any dispute arising out of or relating to this Agreement shall be governed by the laws of the State of Tennessee, without regard to its conflict-of-laws principles. Any action to enforce or interpret this Agreement shall be brought exclusively in a court of competent jurisdiction located in Hamblen County, Tennessee.

15. Construction. This Agreement shall be construed as a whole according to its fair meaning and not strictly for or against any Party by reason of authorship.

16. Severability. If any provision of this Agreement is determined to be invalid or unenforceable, the remaining provisions shall remain in full force and effect to the fullest extent permitted by law, and the invalid or unenforceable provision shall be enforced to the maximum extent permissible.

17. Waiver. No waiver of any breach or provision of this Agreement shall be effective unless in writing, and no waiver shall be deemed a waiver of any prior, concurrent, or subsequent breach.

18. Third-Party Rights. Except for the Released Parties as expressly identified in Section 7, this Agreement is solely for the benefit of the Parties and does not confer any rights or remedies upon any other person or entity.

19. Ownership of Claims. Each Party represents and warrants that it is the sole and rightful owner of the claims, if any, being released by it under this Agreement and that no other person or entity is entitled to assert such claims on its behalf, except as expressly set forth herein.

20. Court Approval. Except as expressly provided in Section 2 regarding board approval and delivery of approval materials, this Agreement is not subject to approval by any court and shall become effective only upon the Effective Date.

21. Entire Agreement. This Agreement constitutes the entire agreement between the Parties concerning the subject matter addressed herein and supersedes all prior or contemporaneous oral or written negotiations, communications, and understandings relating to that subject matter.

22. Authority to Execute. Each individual executing this Agreement on behalf of a Party represents and warrants that he or she is duly authorized and empowered to execute and deliver this Agreement on behalf of that Party. Without limiting the foregoing, Hamblen further represents and warrants that the signatory below has been duly authorized by official action of the Board of County Commissioners reflected in the materials delivered pursuant to Section 2(c). Hamblen waives any defense based on lack of authority inconsistent with the approval materials delivered under Section 2(c).

23. Counterparts; Electronic Signatures. This Agreement may be executed in counterparts, each of which shall be deemed an original and all of which together shall constitute one instrument. Signatures transmitted electronically, including by PDF, shall be deemed originals for all purposes.

IN WITNESS WHEREOF, the Parties have executed this Agreement through their duly authorized representatives.

[Signatures follow on next page]

HOLSTONCONNECT, LLC

By: _____

Dated

Print Name: _____

Its: _____

HAMBLEEN COUNTY

By: Chris Cutshaw

May 21, 2026
Dated

Print Name: Chris Cutshaw

Its: Hamblen County Mayor

CHANGE ORDER FOR BRADY DRIVE STORMWATER PROJECT

Motion by Rodney Long, seconded by Thomas Doty to approve the change order for Brady Drive Stormwater Project.

VOTE RESULTS

12 YES

0 NO

0 ABSTAIN

2 ABSENT

8.h. Change Order for Brady Drive Storm Water Project

Majority of Full Membership

Passed

Joe Huntsman		ABSENT	Rodney Long	M	YES
Debbie Ahearn		YES	Jamie Carden		YES
Thomas Doty	S	YES	Stan Harville		YES
Wayne NeSmith		YES	Peggy Howell		YES
Mike Reed		YES	Bobby Haun		YES
Mike Richardson		YES	Tim Horner		ABSENT
Kyle Walker		YES	Edna Greene		YES

Hamblen County Legislative Body Regularly Meeting
May 21, 2026

MAY 21 2026 04:10:10 PM
OpenMeeting



May 7, 2026

Chris Cutshaw, County Mayor
Hamblen County Courthouse
511 West Second North St
Morristown, TN 37814

Dear Mayor Cutshaw,

Construction is about to begin for the three stormwater projects funded by the TDEC ARPA Water Infrastructure grant awarded Hamblen County a few years ago.

The first project will fix the drainage problem on Brady Drive which has plagued the Alpha Heights neighborhood for many years. The plan will help move the water that normally floods Brady Drive downstream to a sink hole. Complete Construction Management of Morristown submitted the low bid for this project at \$99,500. However, we need to add a couple of items to the project which can be fully funded by the grant. They are:

- 1) Removal and replacement of a large maple tree on the property of Alex and Kaylee Almada at 695 Jenny Lane. The contractor said the excavation work needed to install the drainage pipe on the Almada's property will damage the root system of the tree and eventually cause it to die. I reached an agreement with the property owner that allows us to cut down the tree, grind the stump and replace it with two trees
- 2) The project specifications did not include repaving the heavily damaged section of Brady Drive, which suffers frequent flooding due to inadequate drainage. The residents of the neighborhood have asked that the section of Brady Drive be totally repaved instead of patching the portion of the road that will be dug up to install the drainage system.

The contractor has submitted an estimate totaling \$31,420.85 to remove and replace the tree (\$5,675.35) and to repave a 275-foot section of Brady Drive (\$25,745.50).

I recommend that the County Commission authorizes the additional work and instructs the Finance Department to seek reimbursement for the cost of the work from the ARPA grant. There is currently more than \$460,000 available in grant funds. No county money will be used to make these improvements.

Do not hesitate to contact me with any questions.

Bill Brittain
Stormwater Project Coordinator

511 West Second North Street • Morristown, TN 37814 • office: 423.586.1931 • fax: 423.585.4699

www.HamblenCountyTN.gov • email: Barbara.horton@co.hamblen.tn.us

May 21, 2026

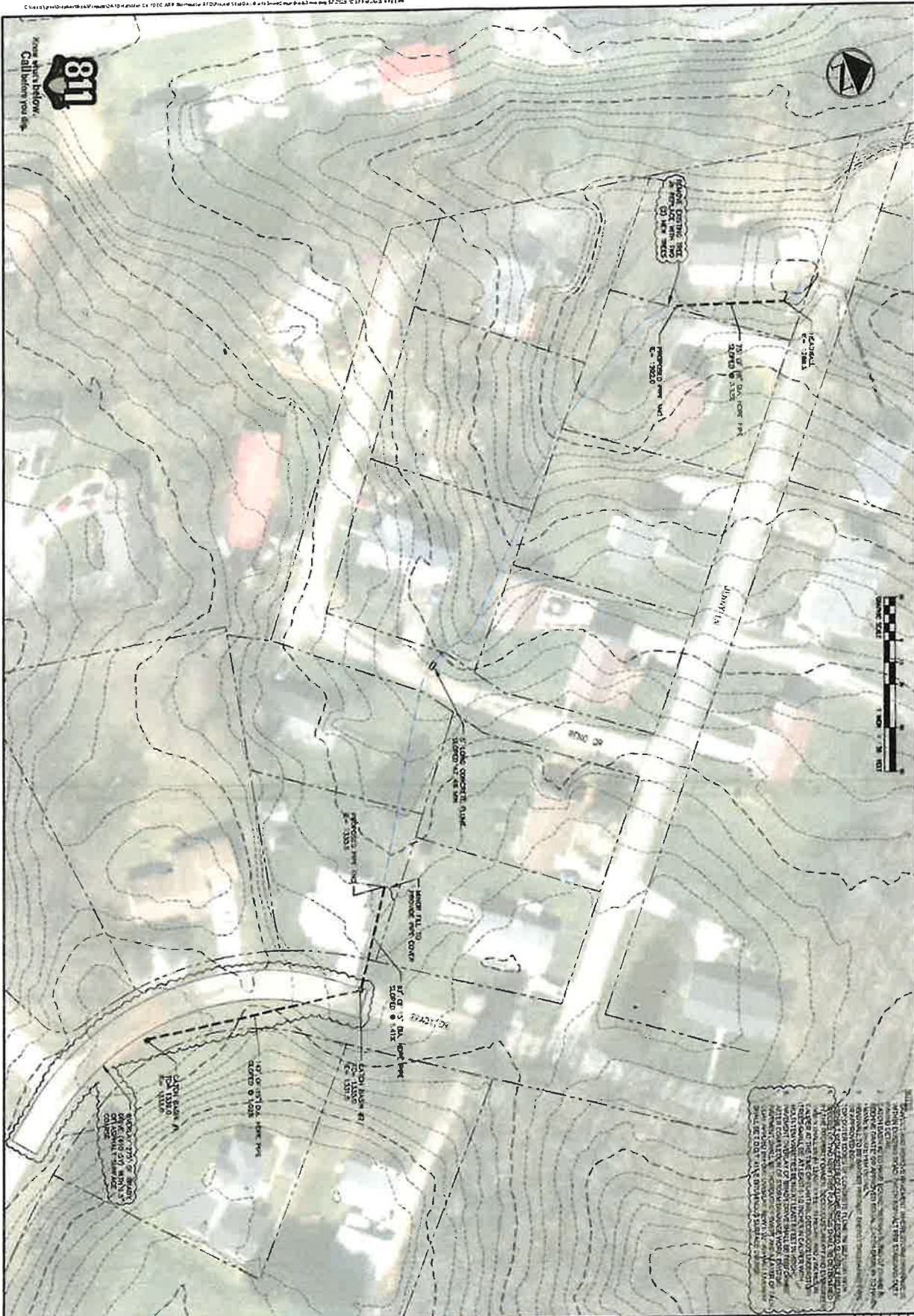

THIS PLAN IS THE PROPERTY OF THE ENGINEER AND IS NOT TO BE REPRODUCED OR TRANSMITTED IN ANY FORM OR BY ANY MEANS, ELECTRONIC OR MECHANICAL, INCLUDING PHOTOCOPYING, RECORDING, OR BY ANY INFORMATION STORAGE AND RETRIEVAL SYSTEM, WITHOUT THE WRITTEN PERMISSION OF THE ENGINEER. THE ENGINEER'S LIABILITY IS LIMITED TO THE PROFESSIONAL SERVICES PROVIDED AND DOES NOT INCLUDE CONSTRUCTION OF THE PROJECT OR THE PERFORMANCE OF THE PROJECT. THE ENGINEER'S LIABILITY IS LIMITED TO THE PROFESSIONAL SERVICES PROVIDED AND DOES NOT INCLUDE CONSTRUCTION OF THE PROJECT OR THE PERFORMANCE OF THE PROJECT.

SHEET C-101	DRAINAGE PLAN	JOB NO: 24-18 DATE: MAY 2025 DRAWN BY: JG CHECKED BY: JG PROJECT REVIEW: <input checked="" type="checkbox"/> FILE NAME: DATE: 11/11/2025	BRADY DRIVE STORM WATER IMPROVEMENTS HAMLEN COUNTY, TENNESSEE		
		RETURN TO REGULAR CALENDAR			

RESOLUTION 26-07

Motion by Rodney Long, seconded by Kyle Walker to accept the TDEC Solid Waste Management Helene Grant.

VOTE RESULTS 12 YES 0 NO 0 ABSTAIN 2 ABSENT

8.i. Resolution 26-07 Majority of Full Membership

TDEC Solid Waste Management Hurricane Helene Grant. **Passed**

Joe Huntsman		ABSENT	Rodney Long	M	YES
Debbie Ahearn		YES	Jamie Carden		YES
Thomas Doty		YES	Stan Harville		YES
Wayne NeSmith		YES	Peggy Howell		YES
Mike Reed		YES	Bobby Haun		YES
Mike Richardson		YES	Tim Horner		ABSENT
Kyle Walker	s	YES	Edna Greene		YES

RESOLUTION 26 - 07

RESOLUTION TO UTILIZE THE TENNESSEE DEPARTMENT OF ENVIRONMENT & CONSERVATION (TDEC) MATERIALS MANAGEMENT GRANT PROGRAM IN FY2026-2027

WHEREAS, The method of the grant offering is to fund subawarded federal grants in a 100% pass-through manner managed by TDEC;

WHEREAS, TDEC, Division of Solid Waste Management, plans to offer reimbursable subaward grants to assist county governments with solid waste and debris cleanup costs related to the aftermath of Hurricane Helene;

WHEREAS, There are 14 Tennessee counties eligible for this funding of which Hamblen County is one of them and can apply under T.C.A. § 68-211-851 A and C. ;

WHEREAS, Subaward recipients will receive funding, with no match requirements, towards capital purchases of equipment and infrastructure needed to repair existing convenience centers, as well as equipment for managing, processing and storing solid waste, recycling, and debris;

WHEREAS, The county legislative body of Hamblen County has determined the best interests is to accept the award of \$284,661.75 and utilize the funds to make capital purchases of a track hoe and containers to benefit Hamblen County Morristown Solid Waste System;

NOW, THEREFORE, BE IT RESOLVED, that the Hamblen County legislative body does hereby approve that the grant funds from the State of Tennessee, Department of Environment & Conservation be used to support Hamblen County solid waste management services:

Approved this 21st day of May, 2026.

APPROVED:

Bobby Haun, Chairman HCLB

APPROVED:

Chris Cutshaw, County Mayor

ATTEST:

Peggy Henderson, County Clerk

May 21, 2026



Department of
**Environment &
Conservation**

**Division of Solid Waste Management
Materials Management Grant Program**

HELENE GRANT OFFERINGS 2025

Introductions



Robin Chance

Grants Program Manager
Division of Solid Waste Management
Materials Management Programs
Direct Phone: 615 – 571 – 6364
Email: Robin.Chance@tn.gov

Cory Lingerfelt– East TN Grant Analyst

Division of Solid Waste Management
Materials Management Programs
Direct Phone: 615-532-0063
Email: Cory.Lingerfelt@tn.gov

Will Nolan – West TN Grant Analyst

Division of Solid Waste Management
Materials Management Programs
Direct Phone: 615-946-5401
Email: Will.Nolan@tn.gov

Ashley Harrison – Grant Analyst

Division of Solid Waste Management
Materials Management Programs
Email: Ashley.Harrison@tn.gov

May 21, 2026

Hurricane Helene Grant - EPA Funded



May 21, 2026

- **Application:**
 - Tentatively March 2026
- **Funding:**
 - Open to 14 Counties
 - No Funding Match Required
 - 2 Application Periods
 - Non-Competitive Amount per County Entity
 - Local partnerships with municipalities encouraged.

Hurricane Helene Grant - EPA Funded

- **When does this application open?**
 - Tentatively Spring 2026 and Fall 2026 **Tentatively*
- **How long is the application open?**
 - 6 Weeks

May 21, 2026

What are the funding amounts?

- TDEC Awarded a total of \$5,000,000
 - 2 Grant cycles of \$2,500,000 will be released Spring of 2026 and Fall of 2026 **tentatively*.
- Up to \$178,571.42 per entity
- No Matches

Hurricane Helene Grant - EPA Funded

- **What can be applied for on this grant?**

- Eligible funding opportunities will be limited to the expenses related to the site infrastructure and equipment for processing, storing, and/or transporting solid waste and debris related to the impacts of Hurricane Helene.
- **Priority 1** - of this subaward funding is the replacement of permitted solid waste and recycling convenience center sites and equipment that were lost or damaged during the Hurricane Helene Disaster.
- **Priority 2** - is upgrading outdated equipment, vehicles, and infrastructure like pavement and/or fencing at solid waste convenience centers.
- **Priority 3** - is purchasing equipment and vehicles for managing debris related to Hurricane Helene.

May 21, 2026

- **Who is eligible for this grant?**

- 14 Tennessee counties in the Hurricane Helene Major Disaster Declaration may apply for grants under T.C.A. § 68-211-851 A and C.

Carter	Greene	Jefferson	Unicoi
Caliborne	Hamblen	Johnson	Washington
Cocke	Hancock	Sevier	
Grainger	Hawkins	Sullivan	

Hurricane Helene Grant - EPA Funded

- ***What are non-eligible expenses?***

- The Department shall not award any grant funds to any region that is not in compliance with the State and Federal rules and regulations.
- Other ineligible equipment or budget items include, but are not limited to:
 - No Land or Property Purchases are permitted,
 - Debris or solid waste deemed as hazardous,
 - Equipment that does not serve the purpose of the priorities of this grant funding opportunity.

May 21, 2026

Hurricane Helene Grant - EPA Funded

- **EPA Requirements for Subaward Recipients?**

- EPA flow-down requirements are the federal grant conditions passed from a prime recipient to a subrecipient to ensure compliance with federal statutes and regulations. The counties are considered a subaward recipient. All subaward entities are required to follow the Federal requirements to receive funding or pass-through funding from other entities.

- (Examples including, but not limited to: NEPA, BABA, T.C.A. § 68-211-101 et seq. (The Solid Waste Management Act of 1991), 2 CFR Part 200, etc.)

- **Link for Federal “Flow-down” Requirement in Manual or can be accessed here:**

- **EPA Pass-Through Subrecipient Flow Down Requirements**
- **Some do not apply, and TITLE VI Compliance and Sam.gov Debarment are completed within the grant application.**
- **Encourage you to start meeting with your entities counsel or purchasing professionals now for review of meeting the correct requirements for this grant.**

May 21, 2026

Questions



May 21, 2026

RESOLUTION 26 - 08 _____

RESOLUTION TO UTILIZE THE STATE OF TENNESSEE
LOCAL HEALTH SERVICES GRANT IN FY2026-2027

WHEREAS, Tennessee Department of Health supports local programs in cities and counties across the state of Tennessee to assist with public health in all 95 counties;

WHEREAS, The mission statement for the Tennessee Department of Health is to protect, promote and improve the health and well-being of all people in Tennessee;

WHEREAS, The grant award between the Tennessee Department of Health and Hamblen County Government is a non-matching grant to support local health services;

WHEREAS, The county legislative body of Hamblen County has determined the best interests of Hamblen County to utilize the annual award for FY2026-2027 in the amount of \$1,472,600.00 and includes \$411,259.55 in federal and \$1,061,340.45 in state funding as a combined pass through award;

NOW, THEREFORE, BE IT RESOLVED, that the Hamblen County legislative body does hereby approve that the grant funds from the State of Tennessee, Tennessee Department of Health be used to support Hamblen County public health services:

Approved this 21st day of May, 2026.

APPROVED:

Bobby Haun, Chairman HCLB

APPROVED:

Chris Cutshaw, County Mayor

ATTEST:

Peggy Henderson, County Clerk

Effective June 2026, the rate for the \$20,000 Basic Life and AD&D benefit provided through US Able Life for all full-time employees will increase 7.5%, from \$2.10 to \$2.26 per employee per month. The school finance team solicited competitive bids; however, the renewal process still resulted in this increase.

Consent Calendar

ME CP

THREE-YEAR RATE BID SHEET		
Bid for Life Rates on Hamblen County Schools AND Hamblen County Government as a Single Group		
	Coverage	Rate
Basic Life (Schools)	\$40,000	<u>\$0.093</u> per \$1,000
AD & D (Schools)	\$40,000	<u>\$0.020</u> per \$1,000
Basic Life (Govt.)	\$20,000	<u>\$0.093</u> per \$1,000
AD & D (Govt.)	\$20,000	<u>\$0.020</u> per \$1,000
Dependent Life	\$10,000 on Spouse \$2,000 on Dependent Children	<u>\$1.760</u> per month
Retirees	\$10,000 to Age 70	<u>\$0.556</u> per \$1,000

COMPANY:
SIGNATURE:
DATE:

USAble Life
Melanie Edwards
May 4th, 2026

RESOLUTION 26-08

Motion by Rodney Long, seconded by Stan Harville to accept the Tennessee Department of Health Local Health Services Grant.

VOTE RESULTS 12 YES 0 NO 0 ABSTAIN 2 ABSENT

8.j. Resolution 26-08

Majority of Full Membership

Tennessee Department of Health Local Health Services Grant

 **Passed**

Joe Huntsman	ABSENT	Rodney Long	M	YES
Debbie Ahearn	YES	Jamie Carden		YES
Thomas Doty	YES	Stan Harville	S	YES
Wayne NeSmith	YES	Peggy Howell		YES
Mike Reed	YES	Bobby Haun		YES
Mike Richardson	YES	Tim Horner		ABSENT
Kyle Walker	YES	Edna Greene		YES

RESOLUTION 26 - 08 _____

RESOLUTION TO UTILIZE THE STATE OF TENNESSEE
LOCAL HEALTH SERVICES GRANT IN FY2026-2027

WHEREAS, Tennessee Department of Health supports local programs in cities and counties across the state of Tennessee to assist with public health in all 95 counties;

WHEREAS, The mission statement for the Tennessee Department of Health is to protect, promote and improve the health and well-being of all people in Tennessee;

WHEREAS, The grant award between the Tennessee Department of Health and Hamblen County Government is a non-matching grant to support local health services;

WHEREAS, The county legislative body of Hamblen County has determined the best interests of Hamblen County to utilize the annual award for FY2026-2027 in the amount of \$1,472,600.00 and includes \$411,259.55 in federal and \$1,061,340.45 in state funding as a combined pass through award;

NOW, THEREFORE, BE IT RESOLVED, that the Hamblen County legislative body does hereby approve that the grant funds from the State of Tennessee, Tennessee Department of Health be used to support Hamblen County public health services:

Approved this 21st day of May, 2026.

APPROVED:

Bobby Haut, Chairman HCLB

APPROVED:

Chris Cutshaw, County Mayor

ATTEST:

Peggy Henderson, County Clerk

BUDGET AMENDMENTS – HCDE AMENDMENT #10

Motion by Rodney Long, seconded by Stan Harville to approve the Budget Amendment #10 from the Hamblen County Department of Education increase of \$2,562,500.21.

VOTE RESULTS 12 YES 0 NO 0 ABSTAIN 2 ABSENT

8.k.1. Budget Amendments - HCDE Amendment #10 Majority of Full Membership

Increase of \$2,562,500.21  **Passed**

Joe Huntsman	ABSENT	Rodney Long	M	YES
Debbie Ahearn	YES	Jamie Carden		YES
Thomas Doty	YES	Stan Harville	S	YES
Wayne NeSmith	YES	Peggy Howell		YES
Mike Reed	YES	Bobby Haun		YES
Mike Richardson	YES	Tim Horner		ABSENT
Kyle Walker	YES	Edna Greene		YES

AMENDMENT # 10

2025-2026

The Hamblen County Board of Education requests approval from the Hamblen County Commission for Amendment #10 to the 2025-2026 General Purpose School Budget. Amendment #10 is pending approval by the Board of Education on May 12, 2026.

Initial Budget	\$ 120,034,856.06
Amendment 1	\$ 4,521,511.73
Amendment 2	\$ 375,724.61
Amendment 3	\$ 214,750.77
Amendment 4	\$ 4,972,416.00
Amendment 5	\$ 67,300.00
Amendment 6	\$ 47,286.00
Amendment 7	\$ 88,600.00
Amendment 8	\$ -
Amendment 9	\$ (230,043.92)
Amendment 10	\$ 2,562,500.21
Total	<u>\$ 132,654,901.46</u>

This amendment does not affect the County's maintenance of effort.



Arnold W. Bunch, Jr., Superintendent of Schools

May 21, 2026

[Return to Regular Calendar](#)

**HAMBLLEN COUNTY DEPARTMENT OF EDUCATION
2025-2026**

Arnold W. Bunch, Jr., Superintendent of Schools

**GENERAL PURPOSE
AMENDMENT #10**



HAMBLÉN COUNTY SCHOOLS
GENERAL PURPOSE SCHOOL BUDGET
2025-2026
AMENDMENT #10 - EXTERNAL

EXPENDITURE CODE	TITLE	BUDGET	INCREASE	DECREASE	ACTUAL	PURPOSE
71100-186-1446	TEACHERS	\$	\$ 695,379.00	\$	\$ 695,379.00	JUNE 2026 SUMMER CAMP BUDGET FOR INSTRUCTION AND TRANSPORTATION
71100-183-1446	EDUCATIONAL ASSISTANTS	\$	\$ 91,879.00	\$	\$ 91,879.00	
71100-201-1446	SOCIAL SECURITY	\$	\$ 45,100.00	\$	\$ 45,100.00	
71100-204-1446	STATE RETIREMENT	\$	\$ 65,105.00	\$	\$ 65,105.00	
71100-212-1446	EMPLOYER MEDIGARE	\$	\$ 10,550.00	\$	\$ 10,550.00	
71100-217-1446	RETIREMENT - HYBRID STABILIZATION	\$	\$ 7,275.00	\$	\$ 7,275.00	
71100-499-1446	OTHER SUPPLIES AND MATERIALS	\$	\$ 82,128.99	\$	\$ 82,128.99	
72110-100-1446	OTHER SALARIES AND WAGES	\$	\$ 5,500.00	\$	\$ 5,500.00	
72110-201-1446	SOCIAL SECURITY	\$	\$ 341.00	\$	\$ 341.00	
72110-204-1446	STATE RETIREMENT	\$	\$ 495.00	\$	\$ 495.00	
72110-212-1446	EMPLOYER MEDIGARE	\$	\$ 80.00	\$	\$ 80.00	
72110-217-1446	RETIREMENT - HYBRID STABILIZATION	\$	\$ 58.00	\$	\$ 58.00	
72120-101-1446	MEDICAL PERSONNEL	\$	\$ 22,000.00	\$	\$ 22,000.00	
72120-201-1446	SOCIAL SECURITY	\$	\$ 1,364.00	\$	\$ 1,364.00	
72120-204-1446	STATE RETIREMENT	\$	\$ 1,900.00	\$	\$ 1,900.00	
72120-212-1446	EMPLOYER MEDIGARE	\$	\$ 320.00	\$	\$ 320.00	
72120-217-1446	RETIREMENT - HYBRID STABILIZATION	\$	\$ 232.00	\$	\$ 232.00	
72130-123-1446	GUIDANCE PERSONNEL	\$	\$ 22,000.00	\$	\$ 22,000.00	
72130-201-1446	SOCIAL SECURITY	\$	\$ 1,364.00	\$	\$ 1,364.00	
72130-204-1446	STATE RETIREMENT	\$	\$ 1,900.00	\$	\$ 1,900.00	
72130-212-1446	EMPLOYER MEDIGARE	\$	\$ 320.00	\$	\$ 320.00	
72130-217-1446	RETIREMENT - HYBRID STABILIZATION	\$	\$ 232.00	\$	\$ 232.00	
72210-105-1446	SUPERVISORS / DIRECTORS	\$	\$ 5,500.00	\$	\$ 5,500.00	
72210-201-1446	SOCIAL SECURITY	\$	\$ 341.00	\$	\$ 341.00	
72210-204-1446	STATE RETIREMENT	\$	\$ 495.00	\$	\$ 495.00	
72210-212-1446	EMPLOYER MEDIGARE	\$	\$ 80.00	\$	\$ 80.00	
72210-217-1446	RETIREMENT - HYBRID STABILIZATION	\$	\$ 58.00	\$	\$ 58.00	
72410-101-1446	PRINCIPALS	\$	\$ 45,500.00	\$	\$ 45,500.00	
72410-201-1446	CLERICAL PERSONNEL	\$	\$ 16,000.00	\$	\$ 16,000.00	
72410-204-1446	SOCIAL SECURITY	\$	\$ 3,900.00	\$	\$ 3,900.00	
72410-212-1446	STATE RETIREMENT	\$	\$ 5,650.00	\$	\$ 5,650.00	
72410-217-1446	EMPLOYER MEDIGARE	\$	\$ 915.00	\$	\$ 915.00	
72410-217-1446	RETIREMENT - HYBRID STABILIZATION	\$	\$ 600.00	\$	\$ 600.00	
72610-100-1446	CUSTODIAL PERSONNEL	\$	\$ 16,000.00	\$	\$ 16,000.00	
72610-201-1446	SOCIAL SECURITY	\$	\$ 992.00	\$	\$ 992.00	
72610-204-1446	STATE RETIREMENT	\$	\$ 1,120.00	\$	\$ 1,120.00	
72610-212-1446	EMPLOYER MEDIGARE	\$	\$ 232.00	\$	\$ 232.00	
72710-145-1446	BUS DRIVERS	\$	\$ 100,026.00	\$	\$ 100,026.00	
72710-201-1446	SOCIAL SECURITY	\$	\$ 6,758.00	\$	\$ 6,758.00	
72710-204-1446	STATE RETIREMENT	\$	\$ 9,810.00	\$	\$ 9,810.00	
72710-212-1446	EMPLOYER MEDIGARE	\$	\$ 1,590.00	\$	\$ 1,590.00	
72710-412-1446	DIESEL FUEL	\$	\$ 22,300.00	\$	\$ 22,300.00	
72710-599-1446	OTHER CHARGES	\$	\$ 40,170.83	\$	\$ 40,170.83	
73100-422-1446	FOOD SUPPLIES	\$	\$ 9,000.00	\$	\$ 9,000.00	
TOTALS		\$	\$ 1,262,500.21	\$	\$ 1,262,500.21	
NET INCREASE			\$ 1,262,500.21			

HAMBLÉN COUNTY SCHOOLS
GENERAL PURPOSE SCHOOL BUDGET
2025-2026
AMENDMENT #10 - EXTERNAL

REVENUE CODE	TITLE	BUDGET	INCREASE	DECREASE	ACTUAL	PURPOSE
41446	OTHER STATE GRANTS	\$	\$ 1,085,116.42	\$	\$ 1,085,116.42	JUNE 2026 SUMMER CAMP ALLOCATION FROM TN DEPT OF ED
47590-1446	OTHER FEDERAL THROUGH THE STATE	\$	\$ 197,383.79	\$	\$ 197,383.79	
TOTALS		\$	\$ 1,282,500.21	\$	\$ 1,282,500.21	
NET INCREASE			\$ 1,282,500.21, 2026			

HAMBLEN COUNTY SCHOOLS
 GENERAL PURPOSE SCHOOL BUDGET
 2025-2026
 AMENDMENT #10 - EXTERNAL

EXPENDITURE CODE	TITLE	BUDGET	INCREASE	DECREASE	ACTUAL	PURPOSE
71100-116	TEACHERS	\$ 36,494,843.72	\$.	\$ 16,000.00	\$ 36,478,843.72	RECLASS TUTORING FUNDS FROM WAGES TO SUPPLIES
71100-429	INSTRUCTIONAL SUPPLIES AND MATERIALS	\$ 487,842.00	\$ 16,000.00	\$.	\$ 503,842.00	
78400-707-1491	BUILDINGS IMPROVEMENTS	\$.	\$ 1,300,000.00	\$.	\$ 1,300,000.00	BUDGET COUNTY ARPA FUNDS FOR JOHN HAY RENOVATION
TOTALS		\$ 36,982,786.61	\$ 1,316,000.00	\$ 16,000.00	\$ 38,282,786.61	
NET INCREASE			<u>\$ 1,300,000.00</u>			

HAMBLEN COUNTY SCHOOLS
 GENERAL PURPOSE SCHOOL BUDGET
 2025-2026
 AMENDMENT #9 - EXTERNAL

REVENUE CODE	TITLE	BUDGET	INCREASE	DECREASE	ACTUAL	PURPOSE
44510-1491	CONTRIBUTIONS & GIFTS	\$.	\$ 1,300,000.00	\$.	\$ 1,300,000.00	BUDGET COUNTY ARPA FUNDS FOR JOHN HAY RENOVATION
TOTALS		\$.	\$ 1,300,000.00	\$.	\$ 1,300,000.00	
NET INCREASE			<u>\$ 1,300,000.00</u>			

BUDGET AMENDMENTS – COUNTY CLERK’S OFFICE

Motion by Rodney Long, seconded by Thomas Doty to approve Budget Amendment Fund #101 County Clerk’s Office for \$16,900.

VOTE RESULTS 12 YES 0 NO 0 ABSTAIN 2 ABSENT

8.k.2. Budget Amendment - County Clerk's Office
Fund #101 in the amount of \$16,900

Majority of Full Membership

Passed

Joe Huntsman		ABSENT	Rodney Long	M	YES
Debbie Ahearn		YES	Jamie Carden		YES
Thomas Doty	S	YES	Stan Harville		YES
Wayne NeSmith		YES	Peggy Howell		YES
Mike Reed		YES	Bobby Haun		YES
Mike Richardson		YES	Tim Horner		ABSENT
Kyle Walker		YES	Edna Greene		YES



Hamblen County Legislative Body Regularly Meeting
May 21, 2026

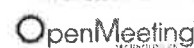



TENNESSEE
Hamblen County
 SERVICE • COMMUNITY • INDUSTRY
 OFFICE OF THE MAYOR

Hamblen County Commission

For the May 2026 Commission Meeting

Fund #101

DEPT: County Clerk's Office

Account Number	Description	Increase	Decrease
	INCREASE APPROPRIATIONS:		
101.52500.317	Data Processing Services	\$ 200.00	
101.52500.349	Printing, Stationery, and Forms	\$ 900.00	
101.52500.399	Other Contracted Services	\$ 500.00	
101.52500.435	Office Supplies	\$ 4,000.00	
101.52500.524	In Service / Staff Development	\$ 1,300.00	
101.52500.709	Data Processing Equipment	\$ 10,000.00	
	DECREASE APPROPRIATIONS:		
101.51600.106	Deputy(ies)		\$ 16,900.00

Brief Descriptions of issue:

To reallocate previously budgeted funds within the County Clerk's Office to cover expenses in excess of budgeted amounts

Signature: Deputy Henderson
 Title: County Clerk
 Date: 5-8-26

For Finance Department Only:
 Reviewed by: _____
 Budget Amendment: _____
 Date: _____

BUDGET AMENDMENTS – COUNTY CLERK’S OFFICE

Motion by Rodney Long, seconded by Thomas Doty to approve Budget Amendment Fund #101 County Clerk’s Office for \$32,000.

VOTE RESULTS 12 YES 0 NO 0 ABSTAIN 2 ABSENT

8.k.3. Budget Amendment - County Clerk's Office Majority of Full Membership
 Fund #101 in the amount of \$32,000  **Passed**

Joe Huntsman		ABSENT	Rodney Long	M	YES
Debbie Ahearn		YES	Jamie Carden		YES
Thomas Doty	S	YES	Stan Harville		YES
Wayne NeSmith		YES	Peggy Howell		YES
Mike Reed		YES	Bobby Haun		YES
Mike Richardson		YES	Tim Horner		ABSENT
Kyle Walker		YES	Edna Greene		YES



TENNESSEE
Hamblen County
 SERVICE • COMMUNITY • INDUSTRY
 OFFICE OF THE MAYOR

Hamblen County Commission

For the May 2026 Commission Meeting

Fund #101

DEPT: County Clerk's Office

Account Number	Description	Increase	Decrease
	INCREASE APPROPRIATIONS:		
52500.709	Data Processing Equipment	\$ 32,000.00	
	DECREASE RESERVED FUND BALANCE:		
34169.0000	Automation for County Clerk		\$ 32,000.00
		32,000	32,000

Brief Descriptions of issue:

To increase appropriations needed for data processing equipment in the County Clerk's Office.
 Funding taken from Clerk's Restricted Automation account for the purchase of printers and upgrading
 Window's operating systems

Signature: Peggy Henderson
 Title: County Clerk
 Date: 4-15-26

For Finance Department Only:
 Reviewed by: _____
 Budget Amendment: _____
 Date: _____

BUDGET AMENDMENTS – DRUG COURT

Motion by Rodney Long, seconded by Thomas Doty to approve Budget Amendment Fund #101 Drug Court for \$9,005.

VOTE RESULTS

12 YES 0 NO 0 ABSTAIN 2 ABSENT

8.k.4. Budget Amendment - Drug Court
Fund #101 in the amount of \$9,005

Majority of Full Membership

 **Passed**

Joe Huntsman		ABSENT	Rodney Long	M	YES
Debbie Ahearn		YES	Jamie Carden		YES
Thomas Doty	S	YES	Stan Harville		YES
Wayne NeSmith		YES	Peggy Howell		YES
Mike Reed		YES	Bobby Haun		YES
Mike Richardson		YES	Tim Horner		ABSENT
Kyle Walker		YES	Edna Greene		YES

Hamblen County Legislative Body Regularly Meeting
May 21, 2026

OpenMeeting
TECHNOLOGIES



Hamblen County Commission

For the May 2026 Commission Meeting

Fund #101

DEPT: Drug Court

Account Number	Description	Increase	Decrease
	INCREASE APPROPRIATIONS:		
101.53330.187	Overtime Pay	\$ 9,000.00	
101.53330.206	Life Insurance	\$ 5.00	
	DECREASE APPROPRIATIONS:		
101.53330.106	Deputy(ies)		\$ 9,005.00

Brief Descriptions of issue:

To reallocate previously budgeted funds within Drug Court to cover overtime expenses for FY 25-26

Signature: *[Signature]*
 Title: Coordinator
 Date: 5/8/26

For Finance Department Only:
 Reviewed by: _____
 Budget Amendment: _____
 Date: _____

BUDGET AMENDMENTS – REGISTER OF DEEDS

Motion by Rodney Long, seconded by Stan Harville to approve Budget Amendment Fund #101 Register of Deeds for \$10,000.

VOTE RESULTS

12 YES 0 NO 0 ABSTAIN 2 ABSENT

8.k.5. Budget Amendment - Register of Deeds
Fund #101 in the amount of \$10,000

Majority of Full Membership

Passed

Joe Huntsman	ABSENT	Rodney Long	M	YES
Debbie Ahearn	YES	Jamie Carden		YES
Thomas Doty	YES	Stan Harville	S	YES
Wayne NeSmith	YES	Peggy Howell		YES
Mike Reed	YES	Bobby Haun		YES
Mike Richardson	YES	Tim Horner		ABSENT
Kyle Walker	YES	Edna Greene		YES

Hamblen County Legislative Body Regularly Meeting
May 21, 2026

OpenMeeting

THEREUPON MEETING ADJOURNED 6:05 PM



Hamblen County Commission

For the May 2026 Commission Meeting

Fund #101

DEPT: Register of Deeds

Account Number	Description	Increase	Decrease
	INCREASE APPROPRIATIONS:		
101.51600.207	Medical Insurance	\$ 6,000.00	
101.51600.709	Data Processing Equipment	\$ 4,000.00	
	DECREASE APPROPRIATIONS:		
101.51600.106	Deputy(ies)		\$ 6,000.00
101.51600.169	Part-Time Personnel		\$ 4,000.00

Brief Descriptions of issue:

To reallocate previously budgeted funds within the Register of Deeds Office to cover changes in employee medical coverage and data processing equipment costs

Signature: [Handwritten Signature]
 Title: Register of Deeds
 Date: 5-7-26

For Finance Department Only:

Reviewed by: _____
 Budget Amendment: _____
 Date: _____